

# RADIO CRAFT

**RESTRICTED  
LAB. AREA**

NO ADMITTANCE EXCEPT TO THOSE  
DIRECTLY CONCERNED WITH PROJECTS  
WITHIN.

C. A. PRIEST

**ANTI-RADAR  
TRANSMITTER**

SEE PAGE 390

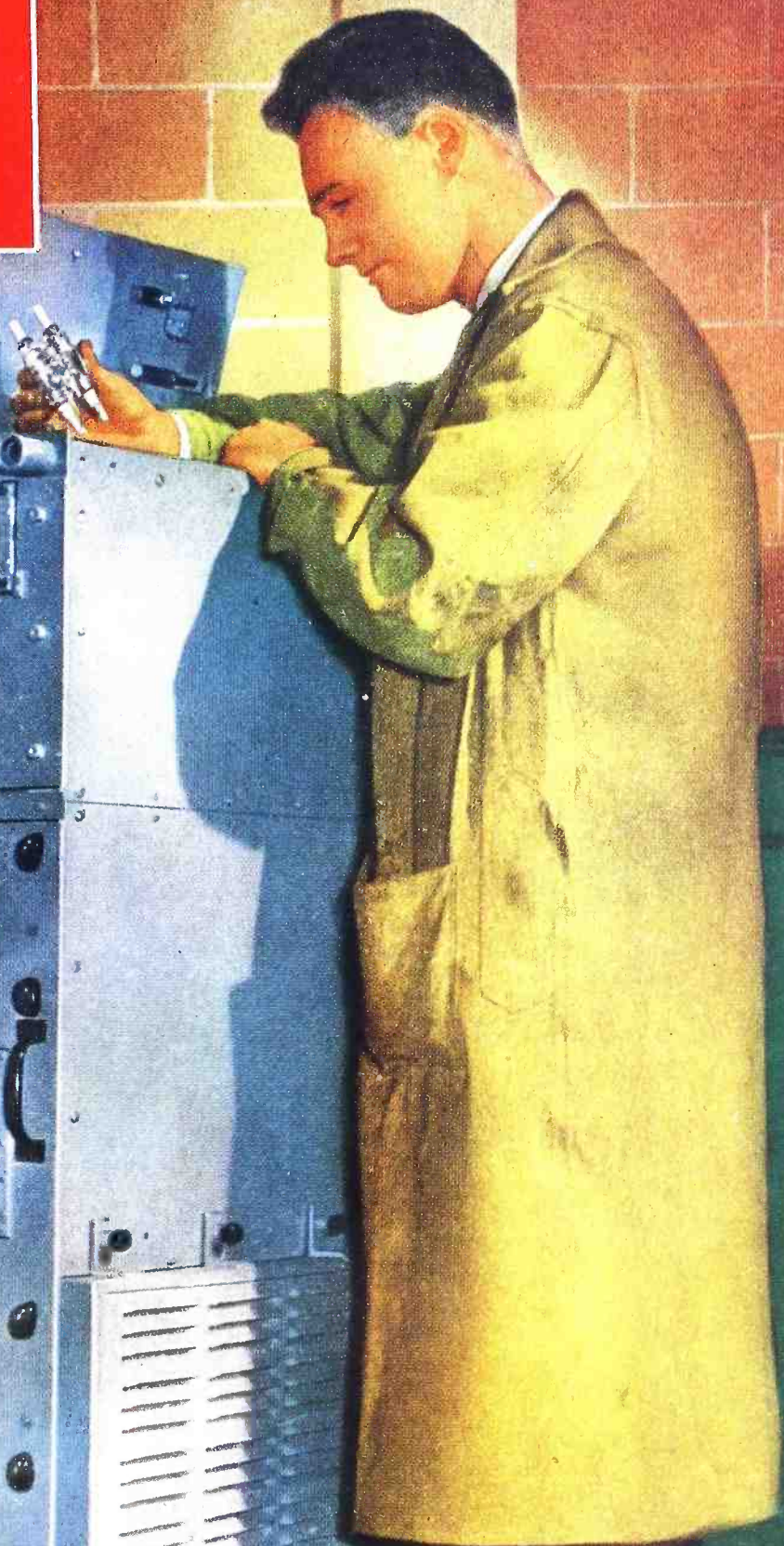
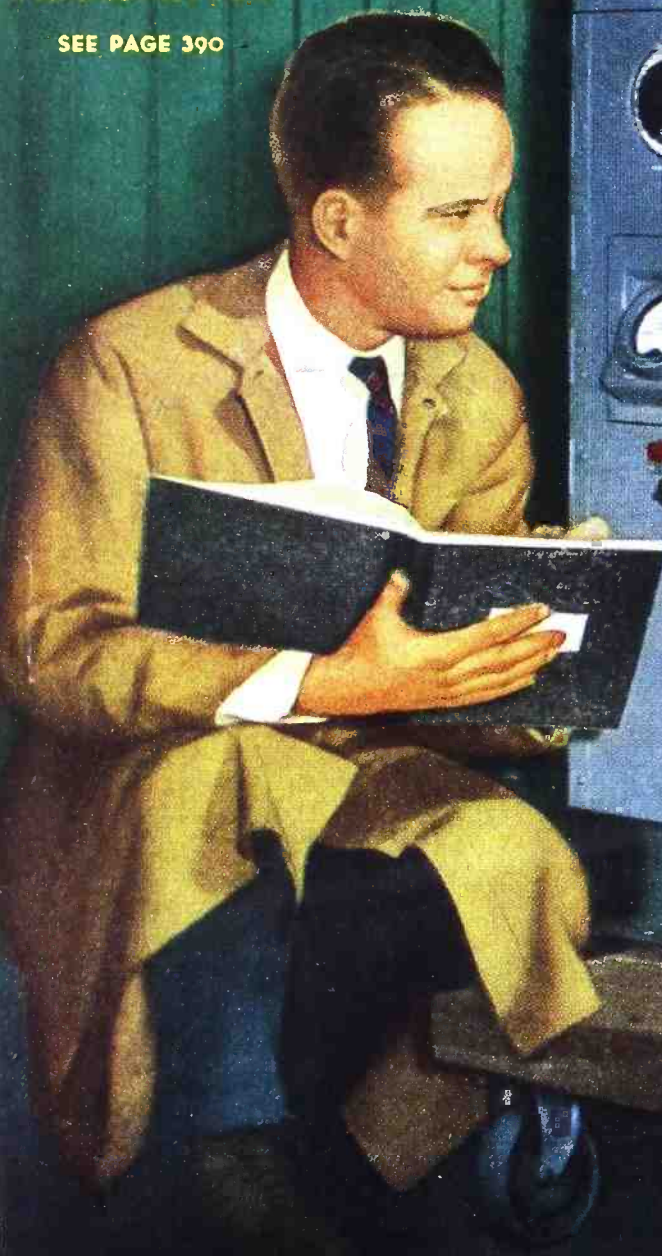

*In this issue—*  
Limiting Circuits  
Sensitive Tracer  
Crystal Filters

**RADIO-ELECTRONICS IN ALL ITS PHASES**

**MAR**

1946

25¢

CANADA 30¢





**Electro-Voice**  
ANNOUNCES THE  
**CARDAX**

A NEW  
**Cardioid Crystal Microphone**

with Revolutionary New **MECHANOPHASE\*** Principle of Unidirectivity . . . Dual Frequency Response . . . High Output . . . and other big features!

**EXCLUSIVE NEW  
MECHANOPHASE\*  
PRINCIPLE  
DEVELOPED BY  
Electro-Voice**

Utilizes a phase shifting diaphragm to produce a high degree of unidirectivity at all frequencies. Gives true cardioid characteristic by nullifying back pick-up. Unlike any previous method of obtaining unidirectivity and has many important advantages.

\*Patents Pending

Here, for the first time, you get *all* these features in *one* microphone! With amazing flexibility, new **CARDAX** efficiently serves many applications . . . easily solves everyday problems of sound pick-up and reproduction!

- ★ **TRUE CARDIOID POLAR PATTERN** New E-V Mechanophase\* principle gives wide-angle front pick-up in true cardioid pattern over wide frequency range. Sound at rear *dead zone* cancels out and is not reproduced.
- ★ **STOPS FEEDBACK—CUTS BACKGROUND NOISE AND REVERBERATION PICK-UP** Permits nearly double usable loud speaker volume. Simplifies microphone and speaker placement. Assures finer reproduction of just the sound wanted.
- ★ **DUAL FREQUENCY RESPONSE** Screw control on back gives (a) Wide range flat response for high fidelity sound pick-up or (b) Wide range with rising characteristic for extra crispness of speech or high frequency emphasis.
- ★ **HIGH OUTPUT LEVEL** —57 db for flat frequency response. —48 db for rising frequency response.
- ★ **VOICE AND MUSIC PICK-UP EXACTLY AS DESIRED** Ideal for public address, recording, remote broadcast, communications . . . indoors and outdoors.
- ★ **FULLY EQUIPPED FOR CONVENIENT OPERATION** Tilting head. Built-in "On-Off" switch. Dual frequency range selector switch. Cable connector. 20 ft. cable. Bimorph crystal. 5/8"-27 thread. New modern functional design. Satin chrome finish. **CARDAX Model 950, List Price . . . . . \$37.00**

Licensed under Brush Patents, Electro-Voice Patents Pending.



**SEND FOR BULLETIN NOW**  
Get full facts about amazing new **CARDAX!** Describes *Mechanophase*. Shows how dual frequency response selector works. Includes diagrams and response curves.

No Finer  
Choice Than

**Electro-Voice**  
**M I C R O P H O N E S**

ELECTRO-VOICE, INC., 1239 South Bend Ave., South Bend 24, Indiana  
Export Division: 13 East 40th St., New York 16, N. Y., U.S.A.—Cables: Arlab





# I Will Show You How to Learn RADIO by Practicing in Spare Time

**I Send You 6 Big Kits of Radio Parts**

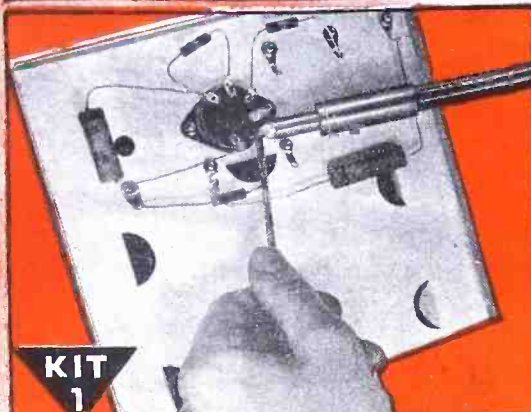

**KIT 1**

I send you Soldering Equipment and Radio parts; show you how to do Radio soldering; how to mount and connect Radio parts; give you practical experience.

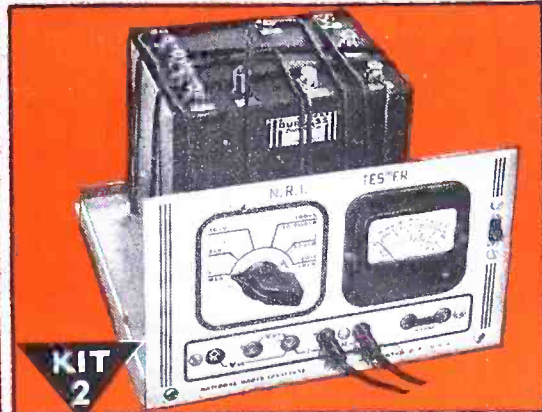

**KIT 2**

Early in my course I show you how to build this N.R.I. Tester with parts I send. It soon helps you fix neighborhood Radios and earn EXTRA money in spare time.

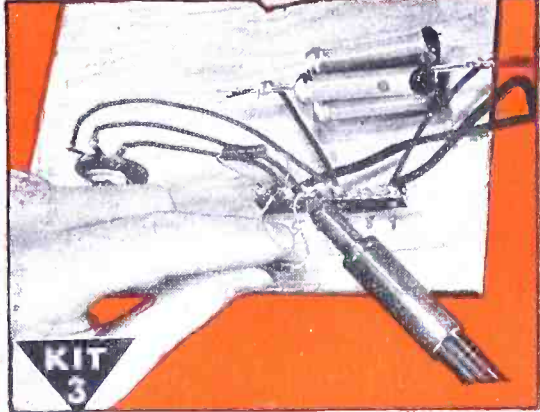

**KIT 3**

You get parts to build Radio Circuits; then test them; see how they work; learn how to design special circuits; how to locate and repair circuit defects.

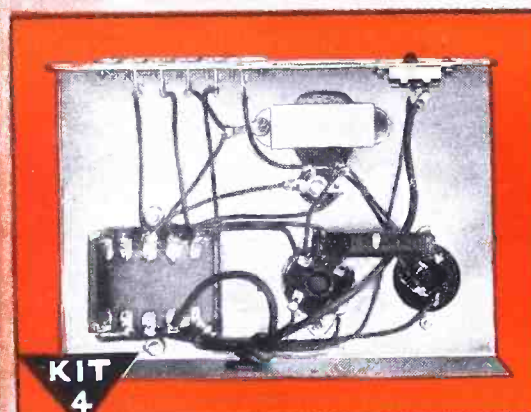

**KIT 4**

You get parts to build this Vacuum Tube Power Pack; make changes which give you experience with packs of many kinds; learn to correct power pack troubles.

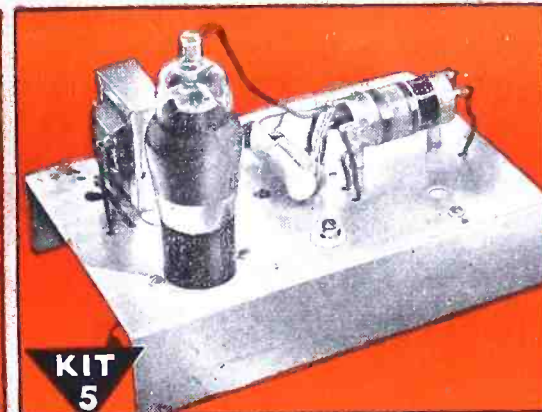

**KIT 5**

Building this A. M. Signal Generator gives you more valuable experience. It provides amplitude-modulated signals for many tests and experiments.



**KIT 6**

You build this Superheterodyne Receiver which brings in local and distant stations—and gives you more experience to help you win success in Radio.

## I Will Train You at Home - SAMPLE LESSON FREE

Let me send you facts about rich opportunities in Radio. See how knowing Radio can give you security, a prosperous future. Send the coupon for FREE Sample Lesson, "Getting Acquainted with Receiver Servicing," and my FREE 64-page book, "Win Rich Rewards in Radio." See how N.R.I. trains you at home. Read how you practice building, testing, repairing Radios with SIX BIG KITS of Radio parts I send you.

### Future for Trained Men Is Bright in Radio, Television, Electronics

The Radio Repair business is booming NOW. There is good money fixing Radios in your spare time or own full time business. Trained Radio Technicians also find wide-open opportunities in Police, Aviation, Marine Radio, in Broadcasting, Radio Manufacturing, Public Address work, etc. Think of the boom coming now that new Radios can be made! Think of the backlog of business

**My Radio Course Includes TELEVISION • ELECTRONICS FREQUENCY MODULATION**

built up in all branches of Radio! Think of even greater opportunities when Television and Electronics are available to the public! Send for free book now.

### Many Beginners Soon Make \$5, \$10 a Week EXTRA in Spare Time

The day you enroll I start sending EXTRA MONEY JOB SHEETS to help you make EXTRA money fixing Radios in spare time while learning. You LEARN Radio principles from my easy-to-grasp Lessons—PRACTICE what you learn by building real Radio Circuits with Radio parts I

send—USE your knowledge to make EXTRA money in spare time.

### Find Out What N.R.I. Can Do for You

MAIL COUPON for Sample Lesson and my FREE 64-page book. It's packed with facts about opportunities for you. Read the details about my Course. Read letters from men I trained, telling what they are doing, earning. Just MAIL COUPON in an envelope or paste it on a penny postal. J. E. Smith, President, Dept. 6CX, National Radio Institute, Pioneer Home Study Radio School, Washington 9, D. C.

### OUR 32nd YEAR OF TRAINING MEN FOR SUCCESS IN RADIO

## Good for Both - FREE

MR. J. E. SMITH, President, Dept. 6CX  
National Radio Institute, Washington 9, D. C.  
Mail me FREE, without obligation, Sample Lesson and 64-page book about how to win success in Radio and Television—Electronics. (No salesman will call. Please write plainly.)

Age .....

Name .....

Address .....

City ..... State ..... 4FR  
(Please include Post Office Zone Number)

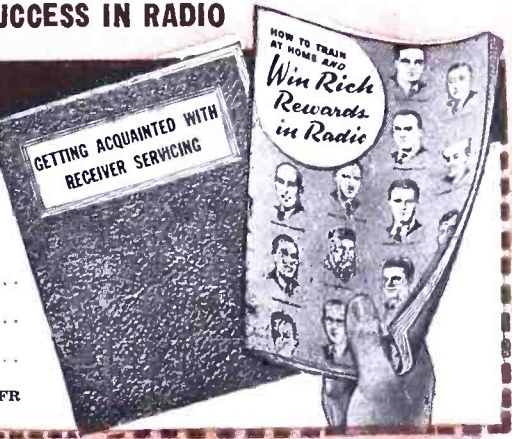



# THE RIGHT COMBINATION

## THORDARSON

TRANSFORMERS  
TRU-FIDELITY AMPLIFIERS

## MEISSNER

COMPONENTS • KITS  
SERVICE EQUIPMENT

## RADIART

VIBRATORS  
RUST-PROOF AERIALS

ONE  
SALES  
SOURCE

ONE  
RESPONSIBILITY

BETTER  
FASTER  
MORE  
COMPLETE  
SERVICE

ELECTRONIC DISTRIBUTOR AND  
INDUSTRIAL SALES DEPARTMENT



# FOR PRECISION-BUILT ELECTRONIC PRODUCTS!

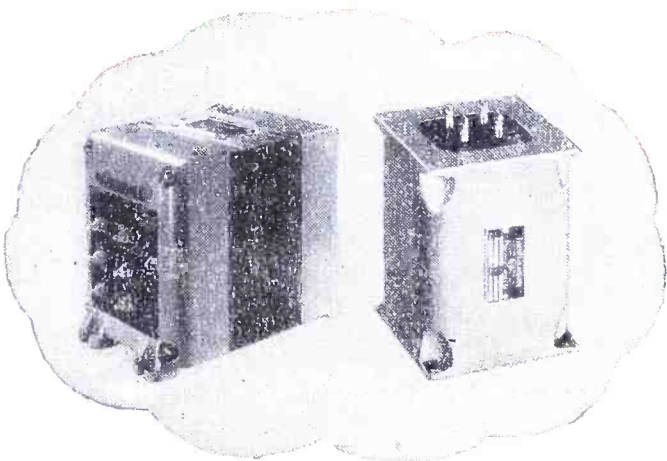

## THORDARSON TRANSFORMERS

Over fifty years experience in the manufacture of quality-built transformers for all applications—replacement, communications, sound amplifier, industrial, experimental and amateur. Thordarson also originated Tru-Fidelity Amplifiers.

## MEISSNER COMPONENTS

The Meissner reputation, gained and maintained by furnishing high quality components, including antenna, R.F. and oscillator coils; standard and Ferrocart transformers; windings, chokes and accessories. Meissner also makes the finest in service equipments.

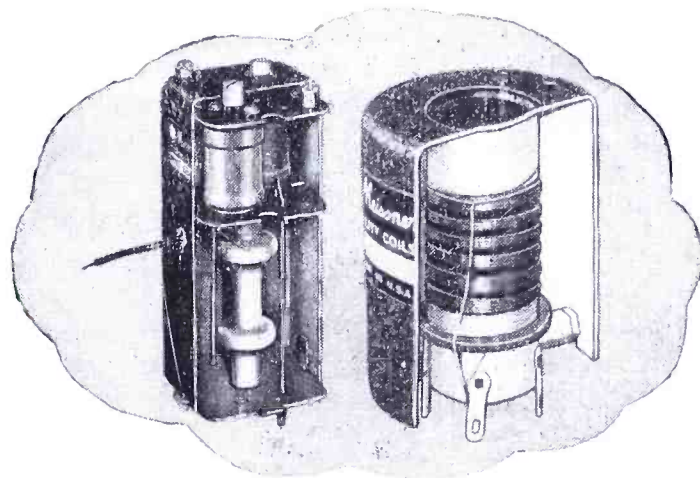

## RADIART VIBRATORS

Radiart Exact Duplicate Vibrators are individually engineered to meet the physical and electrical requirements of each application. This assures longer life, minimum R.F. interference, low hum level, etc. Radiart also makes rust-proof aerials to fit all cars.

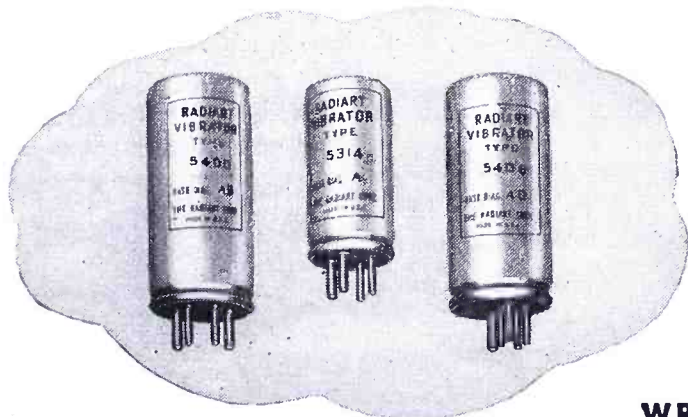

WRITE FOR COMPLETE INFORMATION TODAY!

# MAGUIRE INDUSTRIES, INC.

936 NORTH MICHIGAN AVENUE, CHICAGO 11, ILLINOIS



# N. U. BATTERIES

*by the Carload!*

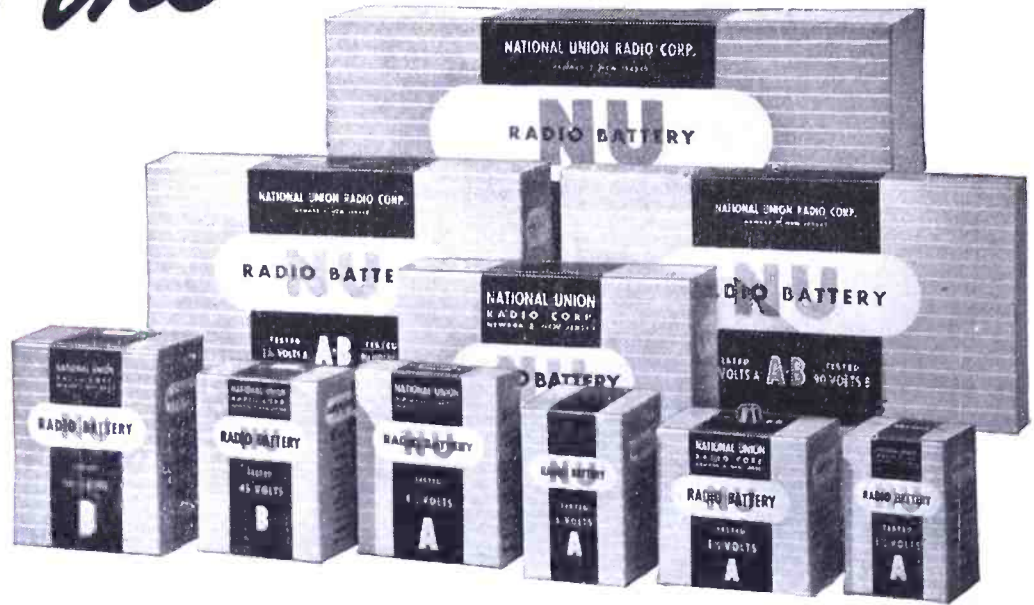

## Get Immediate Deliveries of All Types for Standard Radio and Other Replacements

Now you can bring many thousands of good, serviceable battery-powered radio sets *back to life*. Portables—Farm Radios—"carry-about" sets! Here are the batteries you need to bring in this flood of profitable service and parts business. Order now and *tell* your customers to come on the run for the batteries they need.

In batteries as in other products, N. U. quality helps you build for the future. The patented construction of N. U. Batteries permits more active materials—more service hours per dollar. Every N. U. Battery is engineered to the highest initial equipment standards and is designed for universal replacement.

**PLACE YOUR BATTERY ORDER TODAY—with YOUR N. U. DISTRIBUTOR**

*Renew with N. U. . . . the quality line that brings repeat sales at full profit to radio service men!*

NATIONAL UNION RADIO CORPORATION, Newark 2, New Jersey

## NATIONAL UNION RADIO TUBES AND PARTS

Transmitting, Cathode Ray, Receiving, Special Purpose Tubes • Condensers • Volume Controls • Photo Electric Cells • Panel Lamps • Flashlight Bulbs





# I'LL SHOW YOU HOW TO SUCCEED IN RADIO

Here's the right training for Big Post-War Pay!



F. L. Sprayberry, one of the country's foremost Radio Teachers.

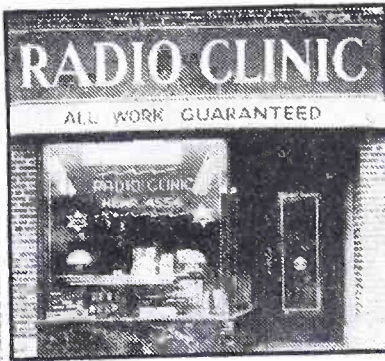

A RADIO SERVICE BUSINESS OF YOUR OWN

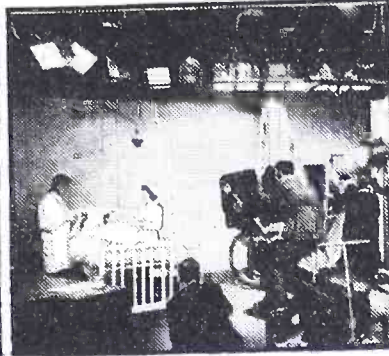

A GOOD JOB IN RADIO & TELEVISION BROADCASTING

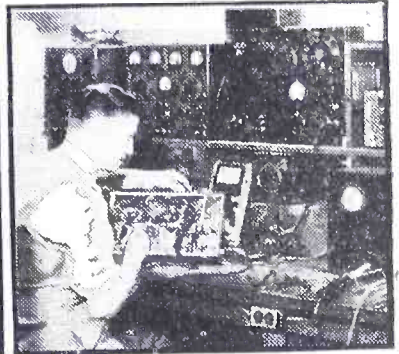

RADIO-ELECTRONIC SERVICE ENGINEER

## BE A RADIO-ELECTRONICIAN

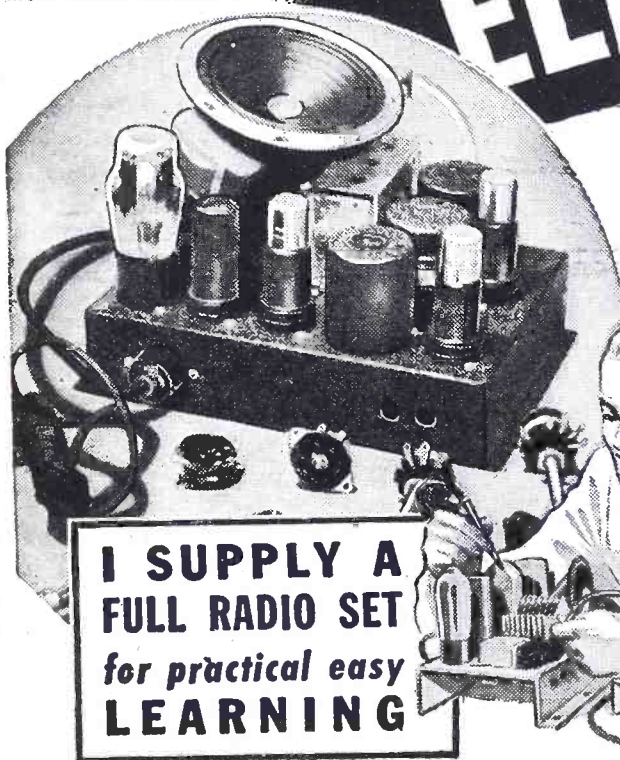

I SUPPLY A FULL RADIO SET for practical easy LEARNING

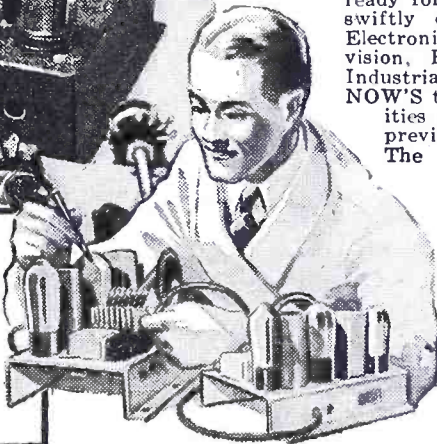

### NOW! YOU CAN PREPARE AT HOME IN YOUR SPARE TIME FOR THE AMAZING OPPORTUNITIES AHEAD IN RADIO — ELECTRONICS — TELEVISION

The offer I make you here is the opportunity of a lifetime. It's your big chance to get ready for a wonderful future in the swiftly expanding field of Radio-Electronics INCLUDING Radio, Television, Frequency Modulation and Industrial Electronics. Be wise! NOW'S the time to start. Opportunities ahead are tremendous! No previous experience is necessary. The Sprayberry Course starts right at the beginning of Radio. You can't get lost. It gets the various subjects across in such a clear, simple way that you understand and remember. And, you can master my entire course

in your spare time. It will not interfere in any way with your present duties. Along with your Training, you will receive my famous BUSINESS BUILDERS which will show you how to make some nice profits while learning.

#### Prepares You for a Business of Your Own or Good Radio Job

My training will give you the broad, fundamental principles so necessary as a background, no matter which branch of Radio you wish to specialize in. I make it easy for you to learn Radio Set Repair and Installation Work. I teach you how to install and repair Electronic Equipment. In fact, you'll be a fully qualified RADIO-ELECTRONICIAN, equipped with the skill and knowledge to perform efficiently and to make a wonderful success of yourself.

### Just Out! FREE!

"How to Read Radio Diagrams & Symbols" . . . a valuable new book which explains in simple English how to read and understand any Radio Set Diagram. Provides the quick key to analyzing any Radio circuit. Includes translations of all Radio symbols. Send for this FREE book now, and along with it I will send you another big FREE book describing my Radio-Electronic training.

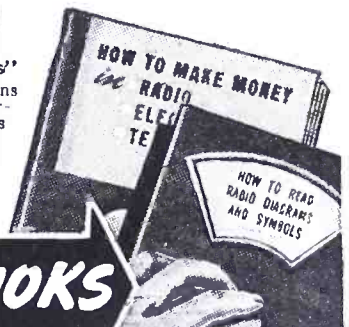

### GET FREE BOOKS

SPRAYBERRY ACADEMY OF RADIO  
F. L. Sprayberry, Pres.  
Room 2036  
Pueblo, Colorado

Please rush my FREE copies of "HOW TO MAKE MONEY IN RADIO, ELECTRONICS and TELEVISION," and "HOW TO READ RADIO DIAGRAMS and SYMBOLS."

Name . . . . . Age . . . . .

Address . . . . .

City . . . . . State . . . . .

Tear off this coupon, mail in envelope or paste on penny postcard.

### SPRAYBERRY TRAINING GIVES YOU BOTH TECHNICAL KNOWLEDGE • SKILLED HANDS

There's only one right way to learn Radio Electronics. You must get it through simplified lesson study combined with actual "shop" practice under the personal guidance of a qualified Radio Teacher. It's exactly this way that Sprayberry trains you . . . supplying real Radio parts for learn-by-doing experience right at home. Thus, you learn faster, your understanding is clear-cut, you acquire the practical "know how" essential to a good-paying Radio job or a Radio business of your own.

#### I'll Show You a New, Fast Way to Test Radio Sets Without Mfg. Equipment

The very same Radio Parts I supply with your Course for gaining pre-experience in Radio Repair work may be adapted through an exclusive Sprayberry wiring procedure to serve for complete, fast, accurate Radio Receiver troubleshooting. Thus, under Sprayberry meth-

ods, you do not have one cent of outlay for manufactured Test Equipment which is not only expensive but scarce.

#### Read What Graduate Says "One Job Nets About \$26.00"

"Since last week I fixed 7 radios, all good-paying jobs and right now I am working on an amplifier system. This job alone will net me about \$26.00. As long as my work keeps coming in this way, I have only one word to say and that is, 'Thanks to my Sprayberry training' and I am not afraid to boast about it." — ADRIEN BENJAMIN, North Grosvenordale, Conn.

#### DON'T PUT IT OFF!

Get the facts about my training—now! Take the first important step toward the money-making future of your dreams. All features are fully explained in my big, illustrated FREE Catalog which comes to you along with another valuable FREE book you'll be glad to own. Mail Coupon AT ONCE!



# RADIO CRAFT

AND POPULAR ELECTRONICS

Incorporating  
SHORT WAVE CRAFT TELEVISION NEWS  
RADIO & TELEVISION



HUGO GERNSBACK, *Editor-in-Chief*  
FRED SHUNAMAN, *Managing Editor*  
M. H. GERNSBACK, *Consulting Editor*  
I. QUEEN, *Editorial Associate*  
ELMER FULLER, *Shortwave Editor*  
E. A. WITTEN, *Technical Editor*  
A. PASCALE, *Production Manager*  
G. ALIQUO, *Circulation Manager*  
JOHN J. LAMSON, *Advertising Director*  
ALFRED STERN, *Promotion Manager*

## IN THE NEXT ISSUE

Hi-Fi Tuner-P. A. Amplifier  
Waveform Shaping Circuits  
Five Foreign Circuits  
Hum Level Reduction

Published by Radcraft Publications, Inc.  
Publication Office: 29 Worthington Street,  
Springfield 3, Mass.  
Editorial and Advertising Offices: 25 West  
Broadway, Tel. RE 2-9690, New York 7, N. Y.  
Chicago Advertising Office: Radio-Craft, 308  
W. Washington Street, Suite 1413, Chicago 6,  
Ill. Tel. Randolph 7363.  
Cleveland Advertising Office: 405 Erie Bldg.,  
Cleveland, Ohio, Burdette Phillips, Manager.  
Tel. Main 9645.  
Los Angeles Advertising Office: 606 South  
Hill Street, Los Angeles 14, Calif. Ralph W.  
Harker, Manager.  
San Francisco Advertising Office: 582 Market  
St., San Francisco 4, Calif. Ralph W. Harker,  
Manager, Tel. Garfield 2481.  
Michigan Advertising Office: 70 Highland  
Ave., Highland Park 3, Michigan. Harry R.  
Lipson, Manager.  
RADIO-CRAFT is published monthly on the  
25th of the month preceding that of date.  
Subscription rates: United States and pos-  
sessions, Mexico, Central and South American  
countries, \$2.50 a year, \$4.00 for two years,  
\$6.00 for three years. Canada, \$3.00 a year,  
\$5.00 for two years, \$7.50 for three years.  
All other foreign countries, \$3.25 a year,  
\$5.50 for two years, \$8.25 for three years.  
Special rates for members of the Armed  
Forces in U. S., or those addressed by A.P.O.  
or F.P.O. mail, \$2.00. Entered at the post  
office at Springfield as second-class matter  
under the Act of March 3, 1879. All com-  
munications about subscriptions should be  
addressed to: Circulation Manager, Radio-  
Craft, 29 Worthington St., Springfield 3,  
Mass.

Notice of CHANGE of ADDRESS should  
reach us at least one month in advance. When  
ordering a change, please furnish an address  
stencil impression from a recent wrapper if  
you can. Address changes cannot be made  
without the old address as well as the new.

### Foreign Agents

London—Atlas Publishing and Distributing  
Co., Ltd., 18 Bride Lane, Fleet St., London,  
E.C. 4.  
Melbourne—McGill's Agency, 179 Elizabeth  
St., Australia.

Text and illustrations of this magazine are  
copyright and must not be reproduced without  
permission of the copyright owners.  
Copyright, 1946, Radcraft Publications, Inc.

## Contents March, 1946 Volume XVII No. 6

Editorial: War-Radio Lessons .....	by The Editor	381
Radio-Electronics Monthly Review .....		382
Radio's Good Old Days (Poem) .....	by Raymond Knight	413
Radio Thirty-five Years Ago .....		419

## ELECTRONICS

"Videosonic" Sound .....	by D. J. Lawson	384
H. F. Crystal Diodes .....	by H. A. LeDuc	386
Pocket Radio Watch .....	by E. A. Witten	389
Anti Radar Equipment .....		390
Limiting Circuits .....	by Jordan McQuay	396
The Crystal Filter .....	by Robert W. Ehrlich	398
Decibel Problems, Part II .....	by John B. Ledbetter	400

## SERVICING

FM Radio Service .....	by Jack King	391
Radio Data Sheet (333) .....		395
Dummies Save Tubes .....	by Earl T. Hartline	437
Improved Compensator .....	by F. C. Davis	425

## CONSTRUCTION

Radio Hearing Aid .....	by Dr. Angelo Montani	392
Hi-Fi TRF Tuner .....	by Wm. F. Frankart	401
Super Reflex Radio .....	by W. T. Connatser	403
Quick Substitution Box .....	by Chester T. Martowicz	434
Another Remote Control .....	by L. R. Blattner	439

## TEST INSTRUMENTS

A Braille Analyzer .....	by W. S. Wartenberg	387
Sensitive Tracer .....	by Clyde Zwicker	393
Capacity Bridge .....	by M. E. Blaisdell	408

## DEPARTMENTS

World-Wide Station List .....	Edited by Elmer R. Fuller	402
New Radio Patents .....	by I. Queen	404
Radio-Electronic Circuits .....		414
Radio-Electronic Devices .....		416
Try This One! .....		418
The Question Box .....		420
Why Not? .....		433
Available Radio-Electronic Literature .....		435
Communications .....		440
Book Reviews .....		441



## ON THE COVER

A magnetron transmitter used in "jamming" enemy radar transmissions and rendering our planes and ships safe from radar-directed fire, is the subject of this month's cover. Such apparatus will have important applications in the postwar field.

Chromatone by Alex Schomburg from General Electric photo



# SILVER

# "VOMAX"

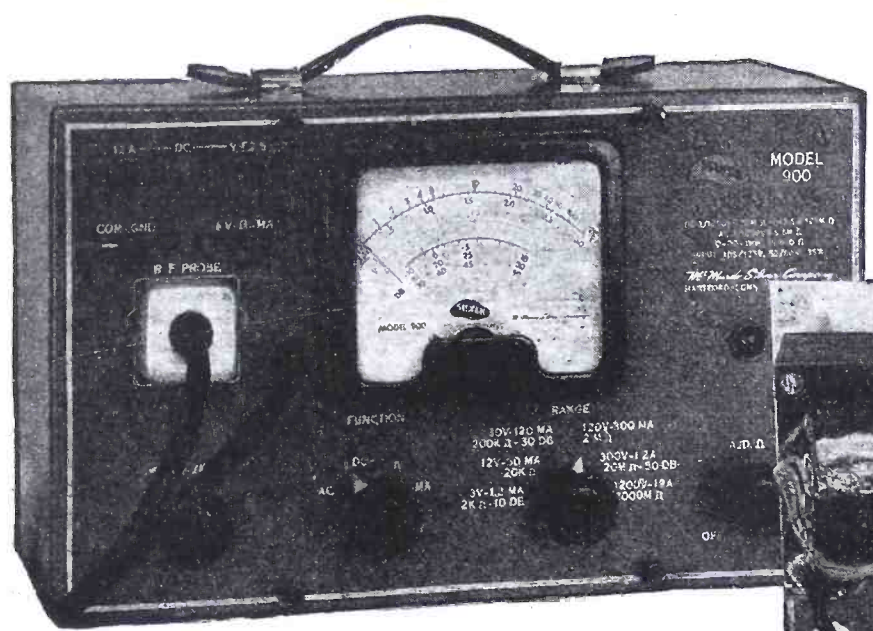

Of construction and quality unmatched by meters selling at far higher prices . . . giving performance exceeding that of three separate instruments costing nearly four times its price . . . it is no wonder we are told that "VOMAX" is today the standard of comparison.

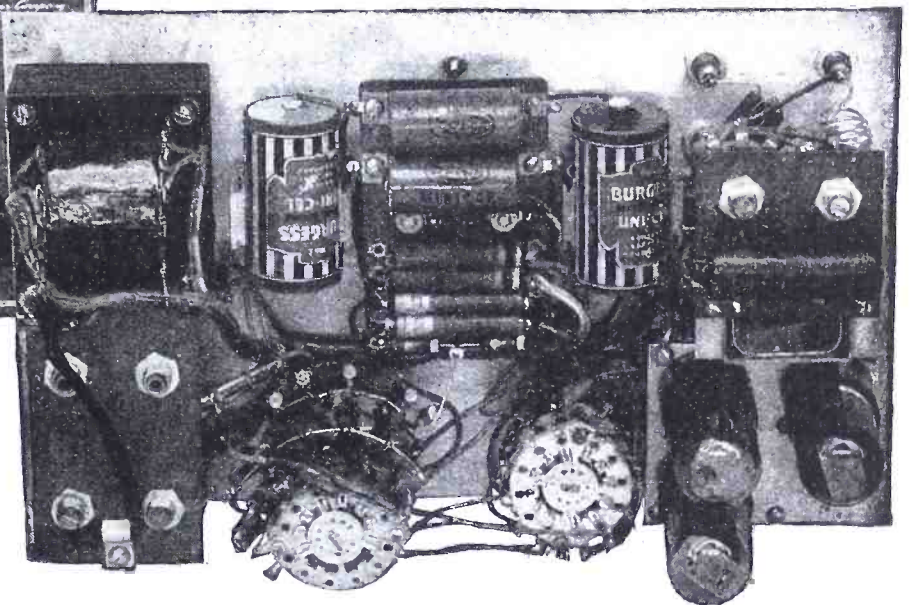

"VOMAX" is new . . . different . . . and outstandingly superior . . . because it is a brand new **post-war** v.t.v.m. . . . and truly universal. With "VOMAX" you can measure **every** voltage required in radio servicing . . . even in the design laboratory. Not only does it enable you to measure d.c. and a.c. voltage at meter resistance so high as not to affect the circuit being measured, but "VOMAX" at last lets you measure a.f. and r.f. voltages from 20 cycles to over 100 megacycles . . . resistance from .2 ohms through 2,000 megohms is "duck soup" with "VOMAX" . . . as is direct current from 50 microamperes through 12 amperes.

Add to all this new visual dynamic signal tracing . . . direct measurement of **every** voltage from receiver antenna to speaker voice coil . . . and you know why many government departments, serious industrial, radio engineering, university research laboratories . . . and service technicians by the thousands clamor for "VOMAX".

"VOMAX" makes you the master, no longer the victim, of tough service problems. Your favorite jobber . . . among nearly 500 progressive SILVER distributors all over the country . . . can give you prompt delivery from his regular monthly allotment . . . if you order now . . . for only

**\$59.85 net**

OVER 34 YEARS OF RADIO ENGINEERING ACHIEVEMENT

*McMurdo Silver Company*

1240 MAIN STREET, HARTFORD 3, CONNECTICUT

## Measures EVERY Voltage

1. Brand new post-war design . . . positively not a "warmed-over" pre-war model.
2. More than an "electronic" voltmeter, VOMAX is a true vacuum tube voltmeter in every voltage resistance db. function.
3. Complete visual signal tracing from 20 cycles through over 100 megacycles by withdrawable r.f. diode probe.
4. 3 through 1200 volts d.c. full scale in 6 ranges at 51 and in 6 added ranges to 3000 volts at 126 megohms input resistance. Plus-minus polarity reversing switch.
5. 3 through 1200 volts a.c. full scale in 6 ranges at honest effective circuit loading of 6.6 megohms and 8 mmfd.
6. 0.2 through 2000 megohms in six easily read ranges.
7. - 10 through + 50 db. (0 db. = 1 mw. in 600 ohms) in 3 ranges.
8. 1.2 ma through 12 amperes full scale in 6 d.c. ranges.
9. Absolutely stable—one zero adjustment sets all ranges. No probe shorting to set a meaningless zero which shifts as soon as probes are separated. Grid current errors completely eliminated.
10. Honest factual accuracy: ± 3% on d.c., ± 5% on a.c., 20Ω through 100 megacycles; ± 2% of full scale, - 1% of indicated resistance value.
11. Only five color-differentiated scales on 4" D'Arsonval meter for 51 ranges (including d.c. volts polarity reversal) eliminate confusion.
12. Meter 100% protected against overload burnout on volts ohms db.
13. Substantial leather carrying handle. Size only 12<sup>3</sup>/<sub>8</sub>" x 7<sup>3</sup>/<sub>8</sub>" x 5<sup>7</sup>/<sub>8</sub>".

Send postcard for free catalog of measurement and communication equipment.



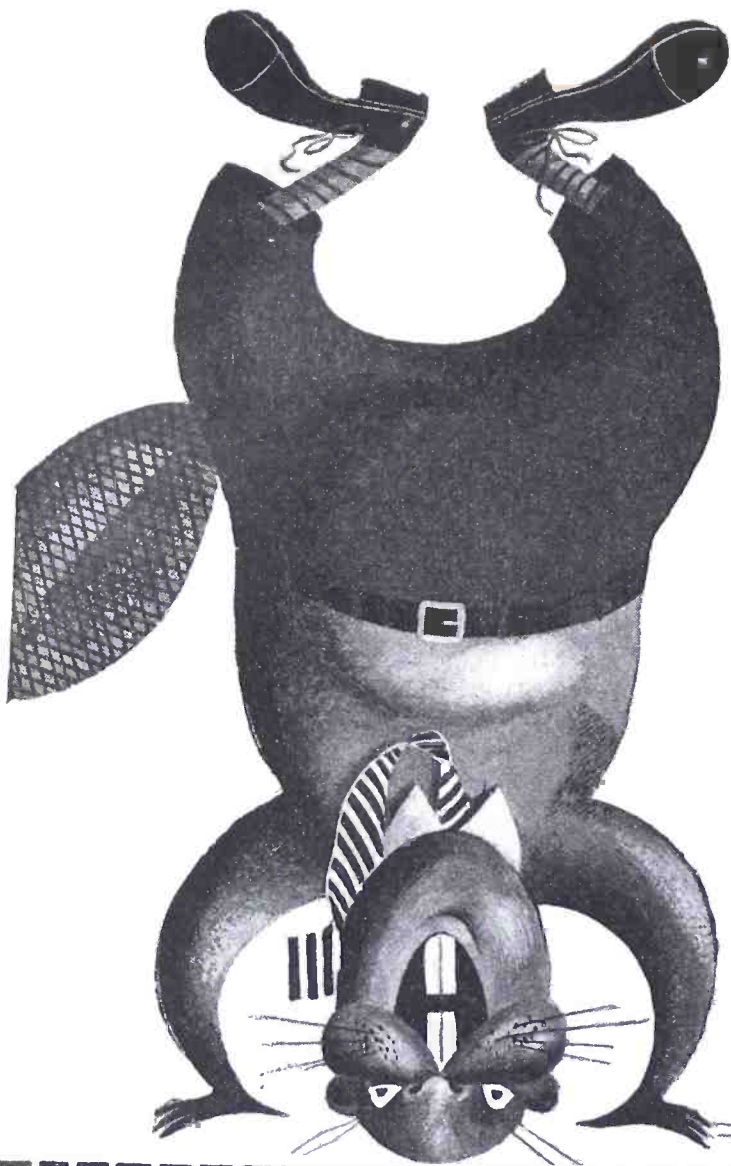

# I used to stand on my head...

... to do an under chassis mounting. That was, until a friend whipped out his C-D catalog. "Pull yourself together," says he, "and take a look at C-D's Blue Beavers."

"There's not a smart servicer in the business who's losing time on capacitor 'shopping' or 'installation.' They all stock these C-D electrolytics! And why not? Did you ever hear of a bigger name in capacitors than Cornell-Dubilier? 36 years of research and engineering is a long time and a lot of experience. Man, these Beavers have a pedigree... they're the stuff you want behind you in a service job."

Well, that fellow sure straightened me out. So I'm passing the good word along. Just to give you an idea of what these dandy Blue Beavers do...

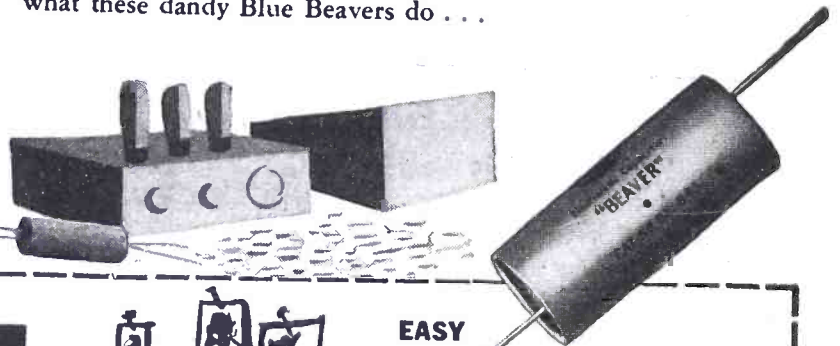

## NO HEAT EXHAUSTION

*Blue Beavers don't droop even when the heat's on and the humidity's up. Strap two or more together for a variety of capacity combinations.*



## EASY INSTALLATION

*Pint-sized in physical dimensions; giants in quality. They're tailor-made for tight spot mounting. Polarity of units is clearly marked on tube casings.*



## READ "THE CAPACITOR" ...

*... for answers to everyday service problems and helpful hints from the experts. It's free; write: Cornell-Dubilier Electric Corporation, South Plainfield, New Jersey.*

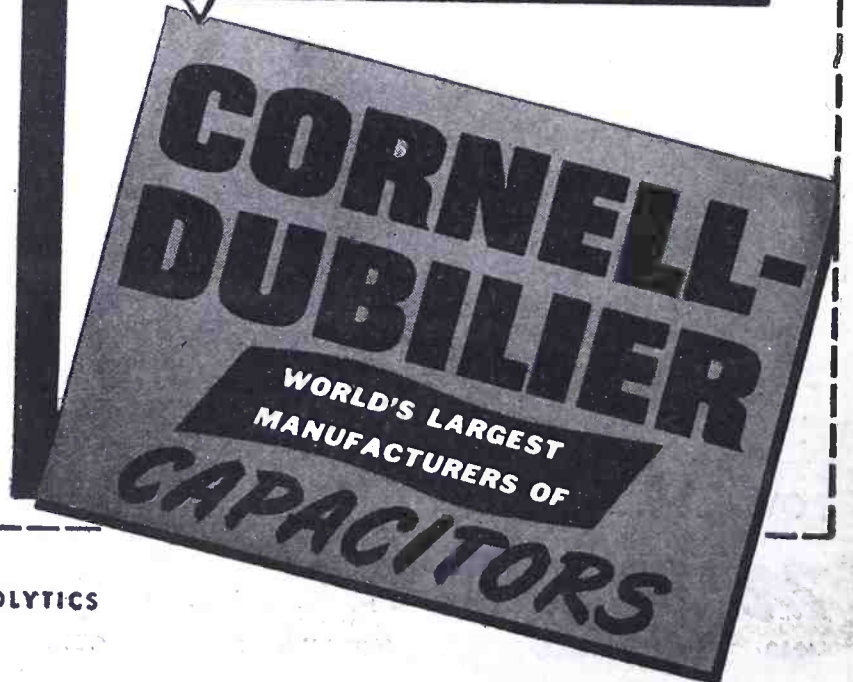

MICA • DYKANOL

PAPER • ELECTROLYTICS



SOON WE'LL PHONE HOME FROM AUTO

RADIO INDUSTRY POISED FOR BIG BOOM

Big Boom in FM Broadcasting

MARKET FOR 100 MILLION RADIOS REVEALED BY SYLVANIA SURVEY

COAST TO COAST NETWORK BEING PLANNED FOR FM

RADAR FUTURE

Let TODAY'S HEADLINES Guide You to TOMORROW'S OPPORTUNITIES

# Learn RADIO ELECTRONICS DeFOREST'S MODERN "A-B-C" WAY .. at Home



YOU CAN BUILD 133 FASCINATING EXPERIMENTS WITH THIS EQUIPMENT

Plan your future the way business men do: Watch the headlines! Pick a field that's "in the news"—one with many opportunities for interesting, PROFITABLE EMPLOYMENT or a good chance for establishing a BUSINESS OF YOUR OWN with little capital. Pick a field that offers a variety of interesting opportunities—a field with one of America's most promising futures . . . and see how you may MAKE YOUR START TOWARD A PLACE IN THIS FIELD BEFORE JOB COMPETITION BECOMES ACUTE. Write for DeForest's Big, Free, Illustrated Book—"VICTORY FOR YOU." Learn how DeForest's prepares you at home, in your leisure time—without interfering with the work you are now doing—then helps you make your start in the vast BILLION DOLLAR Radio-Electronics field.

## You Get EMPLOYMENT SERVICE

DeForest's Employment Service offers you the advantage of long and favorable contacts with some of America's foremost Radio-Electronics concerns. "VICTORY FOR YOU" tells you how this Service has helped many to their start in Radio-Electronics. You'll see how DeForest students and graduates are prepared to win and to hold good paying jobs—how DeForest students start businesses of their own with little, if any, capital.

## A You "LEARN-BY-DOING" at Home with Practical Equipment

Enjoy a "Home Laboratory." DeForest's provides 8 BIG KITS OF RADIO ASSEMBLIES AND PARTS to give you valuable practical experience at home. Build modern Radio Receivers and Circuits that operate. Build Electric Eye Devices, an Aviation Band Receiver, a Public Address System, a Wireless Microphone and numerous other fascinating experiments—in fact, 133 in all, in your spare time at home. NEW colorful Kit Supplement tells you about DeForest's "Home Laboratory," and how you use valuable Radio parts and sub-assemblies to get real practical experience as you learn.

**VETERANS!**  
Big things are happening at DeForest's for veterans! See how we can prepare you WITHOUT COST for a GOOD JOB or a BUSINESS OF YOUR OWN in the vast Radio-Electronic opportunity field.

## C WELL-ILLUSTRATED LOOSE-LEAF LESSONS

DeForest's provides 90 loose-leaf lessons prepared under the supervision of the man often referred to as the "Father of Radio"—Dr. Lee DeForest, inventor of the Audion Tube, and holder of over 300 important patents. . . . ACT PROMPTLY! See how you can learn Radio the

modern A-B-C DeForest's way—by Reading . . . by Doing . . . by Seeing at Home. Mail coupon Now!

## B Home MOVIES Help You Learn FASTER...EASIER



With DeForest's, you use a genuine DeVRY 16 mm. Motion Picture Projector and exciting training films to help you learn some of Radio's fundamentals FASTER . . . EASIER. SEE what happens inside of many circuits you are working on. SEE how electrons function. SEE how RADIO waves are changed into sound. Get DeForest's big, free book! Use it as a key to show you the way to Radio-Electronics job opportunities of today and tomorrow—the opportunities the headlines tell about.

SEND FOR FREE BOOK & SUPPLEMENT TODAY!

# DeFOREST'S TRAINING INC., Chicago, Ill.

DeFOREST'S TRAINING, INC., 2533-41 N. Ashland Ave., Dept. RC-C3 Chicago 14, Illinois, U. S. A. Send me both your big book "VICTORY FOR YOU" and Kit Supplement, showing how I may make my start in Radio-Electronics with your modern A-B-C home training plan. No obligation.



Name \_\_\_\_\_ Age \_\_\_\_\_  
Address \_\_\_\_\_ Apt. \_\_\_\_\_  
City \_\_\_\_\_ Zone \_\_\_\_\_ State \_\_\_\_\_  
 If under 16, check here for special information.  If a discharged veteran of World War II, check here.



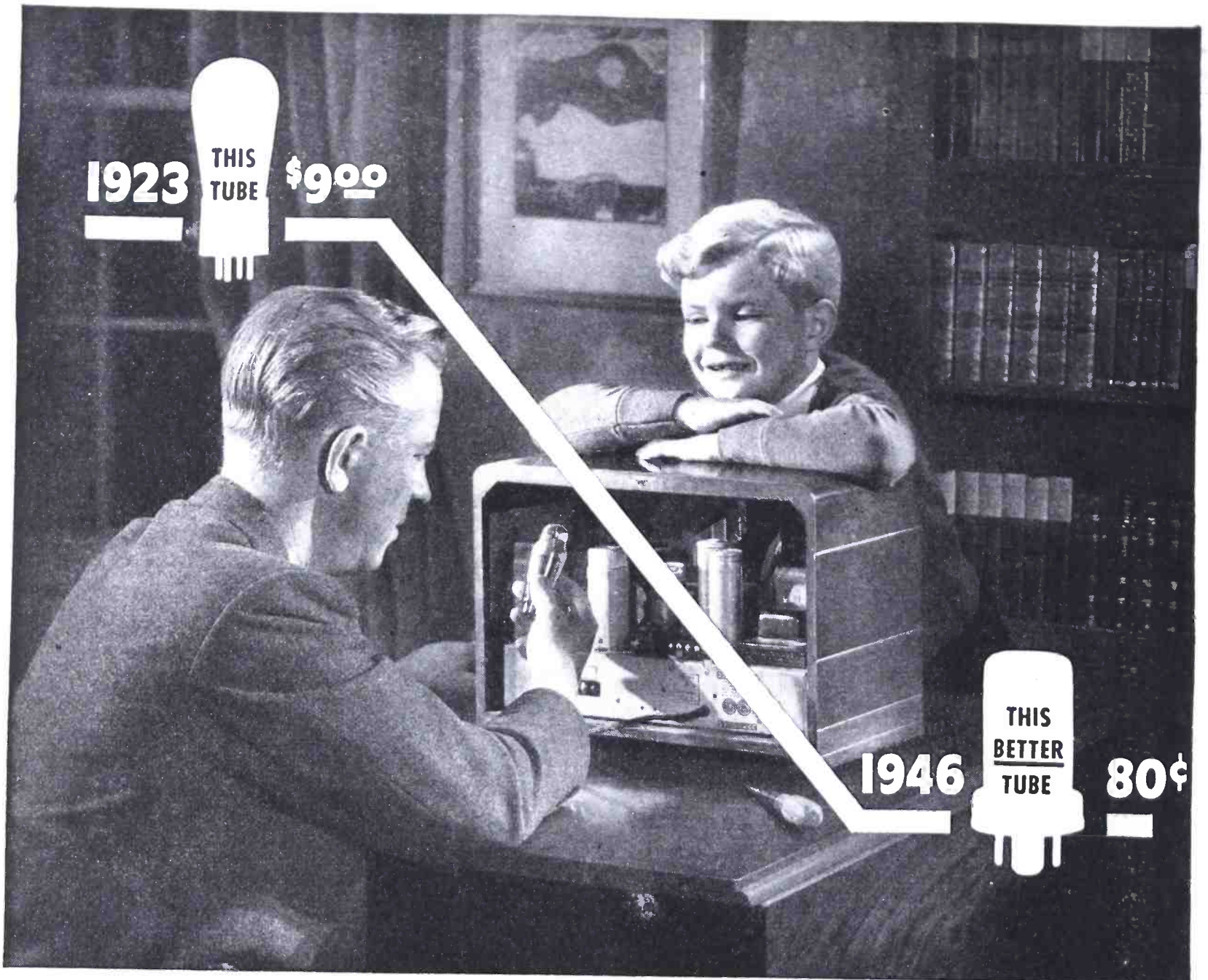

**TODAY-A complete radio set for less than half the cost of the tubes alone in 1923!**

• Today you can buy a six-tube table model radio for about \$25. A little over twenty years ago the six tubes alone cost \$54—*nine dollars apiece*.

Think of it—from \$9 to 80¢. You can buy *eleven* of these more powerful, longer-lasting radio tubes today for what you used to pay for only *one!*

This was brought about through RCA's combination of research, engineering skill, manufacturing efficiency and our American philosophy of making something *better—for less*.

Such progress means far more than simply a saving of \$8.20 on every radio tube. It means that radio has been

brought within the easy reach of practically everyone in this country.

There are now *fifty million* more radios in America than there were twenty years ago. Almost everyone depends upon broadcasting in some measure for entertainment, news, education.

Research and pioneering at RCA Laboratories contributed many of the scientific advances that so greatly improved and extended the services of radio to the American people.

*Radio Corporation of America, RCA Building, Radio City, New York 20, N. Y. . . . Listen to The RCA Victor Show, Sundays, 4:30 P.M., Eastern Time, over the NBC Network.*



The new 1946 RCA Victor Table Model (56X) costing about \$25. With our civilian production increasing, you can again look to RCA for the finest instruments of their kind that science has yet achieved. The principle of making it *better—for less*—applies to RCA Victor radios, television sets, Victrola radio-phonographs . . . every product bearing the RCA label.



**RADIO CORPORATION of AMERICA**



Grasp the **NEW OPPORTUNITIES** in

# RADIO

## ELECTRONICS AND TELEVISION NOW!



Modern Radio—F M broadcast and reception—Television—Radar—Industrial Electronics; power, control, communications—new equipment and methods demand new technical ability and experience. Keep up to date with the latest.

**MODERN ELECTRONIC LABORATORY FOR YOU TO USE AND KEEP**

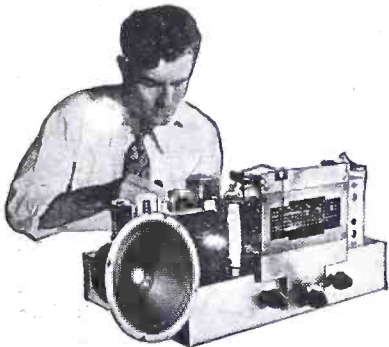

The very essence of National Shop Method Home Training is **EXPERIENCE**. You get the actual experience by working with modern Radio and Electronic equipment—building circuits and instruments. You may build a fine, long distance **MODERN SUPERHETERODYNE** signal generator, miniature radio transmitter, audio oscillator—many other full sized, actual, operating pieces of equipment and instruments—conduct cathode ray and hundreds of other experiments. This experimental laboratory work advances with your training and you actually learn by doing. Send the coupon and get the full details of how such an offer can be made.

## Shop Method Home Training

By a Great Established Resident School

Get one of the thousands of **NEW JOBS** that demand new techniques and methods in modern radio. Get your share of the **NEW BUSINESS** that servicing the new sets and equipment demands. Experts agree that Radio Television and Electronics presents the next great industrial boom!

Radio is expanding farther and faster than ever with great improvements in reception. Radar is already a 2-billion dollar a year business. No one knows yet how great the Television market will be. Electronics touches almost every walk of life—in industry and in the home.

**TURN YOUR INTEREST IN RADIO INTO A CAREER THAT WILL ASSURE YOUR SUCCESS.** Mail the coupon below for a list of the great opportunities in this field—today and in the near future.

### Get the Proper Training

The good jobs in Radio Electronics now go to the men who are equipped to handle them. It takes training and experience. **National Schools**, one of the oldest and best established technical trade schools in the country, makes it possible for you to get this training and experience right in your own home **IN YOUR SPARE TIME**.

Learn right! Get the latest short cuts, trade secrets, straight information.

National maintains one of the biggest resident training shops and laboratories in the United States where instructors, scientists and engineers are working constantly to improve and advance training methods. **SHOP METHOD HOME TRAINING** is a logical extension of this practical system.

A **FREE** lesson that shows you how practical and systematic—how sound, simple and easy this new training method is will be sent you without obligation. You may keep and use this lesson as you see fit. Fill out and mail the coupon below.

### Investigate this Proposition

Where do you stand today in modern industrial progress? What does the future hold for you? You owe yourself this opportunity. It may never come again. With National training **YOU GET AHEAD FAST**—you may step into a good position or start a business of your own, with little or no capital, even before you complete your National course.

Fit yourself for a career of independence, good earnings, a lifetime of success and security in one of the fastest growing fields in the World. But make up your own mind. Get the information first hand. Put your name and address on the coupon and mail it today.

## Get This Book FREE

This big book presents the facts about the field of electronics and your opportunities in it together with full information about the advanced National Training. Read it and make up your own mind that National Training will equip you for a great future. No salesman will call on you from National. The book is **FREE** with your sample lesson. Send the coupon or write.

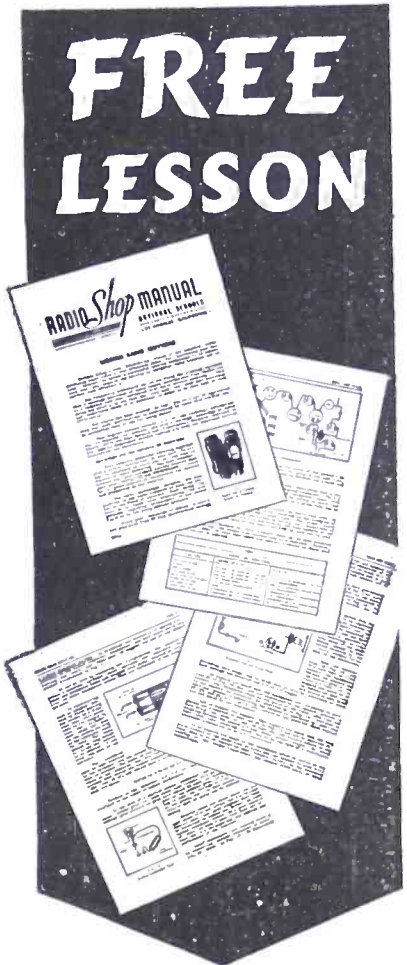

## See What National Training Has Done For These Men!

National Shop Method Home Training wins good jobs, independence and security quickly. Take the word of National men who have established records in their favorite Radio, Television, or other branches of Electronics:

**Joseph Grumich**, Lake Hiawatha, New Jersey writes: "My latest offer was \$5,800.00 as Radio Photo Engineer but I'm doing well where I am now engaged. I am deeply indebted to National."

Here's a statement from **R. R. Wright**, Blackfoot, Idaho: "Due to my training at National I was selected to instruct in the laboratory work of Navy and Marines."



From **O. K. Ivey**, Washington, D. C., comes this endorsement: "I believe National offers the best course to be had. Keep up the good work."

**Robert Adamsen**, Kearney, Nebraska. A national graduate, has two radio jobs—makes double pay as a radio instructor and as engineer at Station KGFW. He writes: "I am proud of My National training and appreciate the cooperative spirit."



Read what hundreds of other enthusiastic students have written about National Training. Send in your coupon today.



## NATIONAL SCHOOLS

LOS ANGELES 37, CALIFORNIA EST 1905



### MAIL OPPORTUNITY COUPON FOR QUICK ACTION

National Schools, Dept. RC-3  
4000 South Figueroa Street, Los Angeles 37, California

(Mail in envelope or paste on penny post card)

Mail me **FREE** the two books mentioned in your ad including a sample lesson of your course. I understand no salesman will call on me.

NAME ..... AGE .....

ADDRESS .....

CITY ..... STATE .....

Include your zone number



*Men!* You Need "All-Around" Training  
for Tomorrow's Better Jobs in



# RADIO-ELECTRONICS and TELEVISION

*"Learn by Doing"*

— 12 FASCINATING WEEKS  
of STREAMLINED TRAINING

You like Radio work. But if you're really serious about making it your lifetime career, GET PRACTICAL TRAINING NOW. Don't be satisfied to putter along in a "one-operation" no-future job. Prepare for better pay and advancement with Coyne all-around training in Radio-Electronics-Television.

### Many Branches Included

Here in the great shops of Coyne in Chicago, you're trained in everything from basic principles and Radio construction, to F. M. (frequency modulation), electronic controls, public address systems, television and radio-phonographs. You can even get valuable extra training in Industrial Electronics and Electric Refrigeration at no extra cost, for still more opportunities in the years ahead. Coyne gives "all-around" training!

### Work on Real Equipment

You work on real actual equipment and expert instructors give you necessary theory in blackboard lectures and demonstrations. In 12 WEEKS OR SO—you're ready for a real future!

### Starting Your Own Radio Shop

Want to be your own boss, with a fine-paying radio shop of your own? We show you how to set one up and operate it successfully. Hundreds of Coyne graduates are doing it. You can, too. Send now for details.

### Get the Facts — FREE!

My new giant Radio Opportunity Book has dozens of shop pictures, facts about Radio and Television jobs, my plans to help you. Rush coupon today. No obligation; no salesman will call. You alone will decide. But don't delay. Act NOW.



H. C. Lewis

## Send for Details on My STUDENT FINANCE PLAN

If you don't have much cash, I'll arrange to finance most of your tuition and you can pay it back in easy monthly installments after you graduate. We'll even help you get a part-time job if you wish, so you can EARN WHILE LEARNING. My LIFETIME EMPLOYMENT SERVICE is free to Coyne Graduates. Coyne Training is the finest investment you can make.

### MEN WITH PHYSICAL DISABILITIES

Also facilities for men with physical disabilities, whether due to war or other causes. Check coupon for special information.

THE HOME OF  
COYNE



### VETERANS!

Coyne is also equipped to train those who qualify for training under the G. I. Bill of Rights. Check the coupon for special G. I. Bulletin.

H. C. LEWIS, Pres.

Founded 1899

**COYNE** ELECTRICAL SCHOOL  
RADIO-ELECTRONICS DIV.

500 So. Paulina Street, Dept. 36-8H, CHICAGO 12, ILLINOIS

H. C. Lewis Pres., Radio-Electronics Div.,  
COYNE ELECTRICAL SCHOOL,  
500 S. Paulina St., Dept. 36-8H  
Chicago 12 Ill.

I want to build a REAL FUTURE for myself. Send your big FREE BOOK on Radio-Electronics, also details of your Student Finance Plan. Check if you are interested in information on the following:

- Send special G. I. Bulletin
- Send details on Physical Disability

NAME.....

ADDRESS.....

CITY.....STATE.....



# WAR-RADIO LESSONS

**. . . . War-radio has made radio history . . . . It already has strongly affected all peacetime radio engineering . . . .**

**D**URING the past few months we have received a number of letters from readers who strongly object to our wartime disclosure articles in RADIO-CRAFT. For the record, let it be stated that the influx of such letters was by no means large, which speaks well for the majority of our readers who kept their feet on the ground. There is always a small minority who are so blinded by their prejudices that they cannot visualize that wartime radio has actually compressed ten to twelve years of radio development into a short four-year period.

As we have mentioned here before, RADIO-CRAFT would be singularly derelict in its duty if it did not present to its readers ALL the important war developments, particularly those which will affect radio completely, during the years to come. Those benighted readers who write adversely about RADIO-CRAFT's reportage of important radio development, completely forget that *they themselves will be using scores of radio war applications in their own radio work in the very near future.*

Let us review just a few of the more important war-radio developments which are already in the peace service now.

Loran, one of the brilliant wartime radio navigation developments, is actually being used now on a great many ships. *Exact* navigation is today a routine performance, a thing which was never possible before. Dead reckoning, "shooting the sun," are rapidly becoming obsolete. Loran for both ship and airplane has established extremely accurate navigation. It became an everyday performance a few short months after V-J Day.

It is certain that even such light craft as yachts and motor boats will, in due time, be Loran-equipped. Thus, those servicemen who object to the publishing of wartime radio articles dealing with it, will be called upon, in the not too distant future, to service such Loran-carrying small boats!

We have mentioned the peacetime uses of radar a number of times before, so we will not repeat them here, except add a recent one whereby the blind can now be guided by means of quasi-radar portables. These are already appearing on the market and they too may have to be serviced by the very objectors to "wartime information."

Radar, Loran, and other war inventions created overnight a demand for cathode-ray tubes, such as never existed in the past. Never mass-produced before, they were made by the hundreds of thousands during the war years. The tremendous experience gained in this mass-production of cathode-ray tubes not only brought vast improvements to that art, but also appreciably reduced the price.

Cathode-ray tubes will have thousands of different new applications during the coming years. As every thinking

radioman knows, this probably would not have happened so soon if it had not been for the wartime pressure in that field.

Another wartime radio application—the proximity fuse—was directly responsible for advancing miniature radio tubes to an undreamed-of extent. We are now reaping the peacetime benefits and our miniature sets, which are now beginning to appear on the market, are the immediate result of the invaluable radio research in proximity-fuse engineering.

The handie-talkie war development is coming into rapid realization in Citizen's Radio, police radio, and many other applications. Here again the mass-production of the handie-talkie, as well as the walkie-talkie, has advanced the art in this particular domain tremendously.

Radar engineering has already given us today, pulse-time or pulse-position modulation. Wartime applications of micro-waves have given us communication between trains, as well as communication between different sections of the same train, besides many other commercial applications.

The magnetron, without which high power micro-waves would not be practical today, is also in part a wartime radio application. From the magnetron many other new applications will be found in the very near future. The power Klystron too owes much to wartime research.

Speaking generally, wartime advances have also greatly changed many radio components. Radio tubes, radio condensers, and resistors—all have been improved in many different ways. This is often not apparent on the surface, and it is necessary to have some knowledge of wartime applications of many of the components to understand the "how" and "why."

Take, for instance, electrolytic condensers. They now measure only a fraction of the size which they were before the war. So do resistors. Both of the latter components, due to stringent wartime requirements, will now work at much *higher* temperatures, as well as much *lower* temperatures, because of unusual demands that were made upon them during the war.

Before the war, the manufacturers of many radio parts did not have to worry about operation in the steaming tropics, nor in temperatures of 40 below zero. These were routine wartime requirements and occasioned a complete revolution in the building of any number of radio components. This again means that when future sets are being serviced, they will not fail as frequently as they did before the war.

The few examples cited here should be sufficient to drive home the lesson that the present-day radioman must consistently expand his radio horizon if he wishes to be well informed of what is going on, *even in his own field.* It should be an axiom that every branch in radio and electronics is profoundly affected by every other branch in radio and electronics.



**MAGNETIC RECORDING** on paper tape was demonstrated last month by the Brush Development Co. The paper is coated with an extremely thin film of iron particles so that it will reproduce a recorded signal with high fidelity. The coated paper tape is, of course, much cheaper than metal tape previously used for magnetic recording.

In addition to its cheapness, the new magnetized paper tape offers several other advantages. It is easier to handle than wire or other metallic recording mediums since it is less "springy" and has larger physical dimensions. It is wound on regular 8-mm film reels and can quickly and easily be wound and re-wound from reel to reel simply by inserting the end into a slit in the hub of the reel. The paper tape can be edited simply by tearing out any undesired sections and splicing the remaining sections with Scotch tape or any other suitable adhesive. No break is detectable on playback when this is done.

Besides making home recordings, the paper-tape unit is adaptable to recording radio programs. Once hooked into the radio by a serviceman, recordings of any programs coming over the air can be made simply by pushing the "record" button. Upon completion of a recording the rewind button is pushed and within a few seconds the recording is ready for playback. Each reel of paper tape can accommodate a half hour of recording, and the required rewind time is well under one minute. Playback is accomplished without any changing of reels. Automatic controls contained in the unit assure proper volume level and control.

**ELECTRONIC HOT DOGS**, long distributed to spectators at demonstrations of high-frequency heating, will be available to the public at the drop of a dime into an ordinary vending machine, General Electric engineers announced last month.

Electronic hot dogs have long been cooked by high-frequency engineers to show what dielectric heating could do—one of the first set-ups was pictured on

the cover of the Gernsback magazine *Short Wave Craft* in November, 1933. So far only a chosen few have been privileged to taste them. Now they will be as available as such other mechanically sold products as Coca-Cola and cigarettes.

The electronic canteen, which will serve the hot dogs, hamburgers, or grilled cheese sandwiches at the drop of a dime and the push of a button, is slightly larger than the usual soft drink or cigarette machine. It plugs into the regular 117-volt outlet, has a decorative front door with appropriate mirror; push-button selectors for choice of food; a glass window in front of the electronic unit and coil so the customer can see his food getting the heat—by radio; and below a glass door and compartment into which the hot dog or sandwich drops when ready to eat.

The oscillator used to heat the canteen items is operated by two specially developed high-frequency power oscillator tubes. Over a thousand different types of oscillators were built and tried before the problem of heating rolls and meat uniformly without burning was overcome, according to G.E. transmitter division experts who worked out the mechanical and electrical designs with Automatic Canteen Co. engineers. Some frequencies would heat the roll but not the frankfurter. Other frequencies would heat the frankfurter but burn the roll. Then when it looked as though both bun and meat would heat uniformly, one end of the bun would burn. Finally the right frequency was found and tubes and a special coil developed which would deliver the right amount of heat uniformly over the hot dog.

It should *not* be construed from this development that the electronic stove is just around the corner, electronic engineers hasten to explain. The canteen grill and the electronic stove present two different kinds of problems and the accomplishments in the development of the former should not be interpreted as solving the problems yet to be overcome in the field of electronic cooking.

**PEACE-TIME RADAR** is already an accomplished fact, stated Raytheon Manufacturing Co., in a report last month. Approximately 75 percent of the transports returning soldiers to this country were equipped with radar at the time the report was prepared. It was expected that by the time of the report's release, the number would have been increased to 100 percent.

Radar eliminates the delays caused by bad weather or poor visibility. A pencil-sharp beam constantly searches the area all around the ship, giving a map-like presentation on the radar indicator of anything that falls within its range. Other ships, icebergs, buoys . . . even driftwood, are spotted with an accurate indication of their bearing and distance. It is estimated that the return of troops has already been speeded up by the use of radar. It has, to a great extent, eliminated the necessity for reducing speed during periods of poor visibility and for waiting outside of harbors for fog to lift.

At least one disaster was averted by the efficient use of radar during and following storms in British waters this winter. No troop-transport accident has ever occurred on ships equipped with SO-1 or SO-8 radar.

Messrs. Baker and Leverone, of G-E and Automatic Canteen, try a dog. This portable recorder works with a strip of magnetized paper tape.

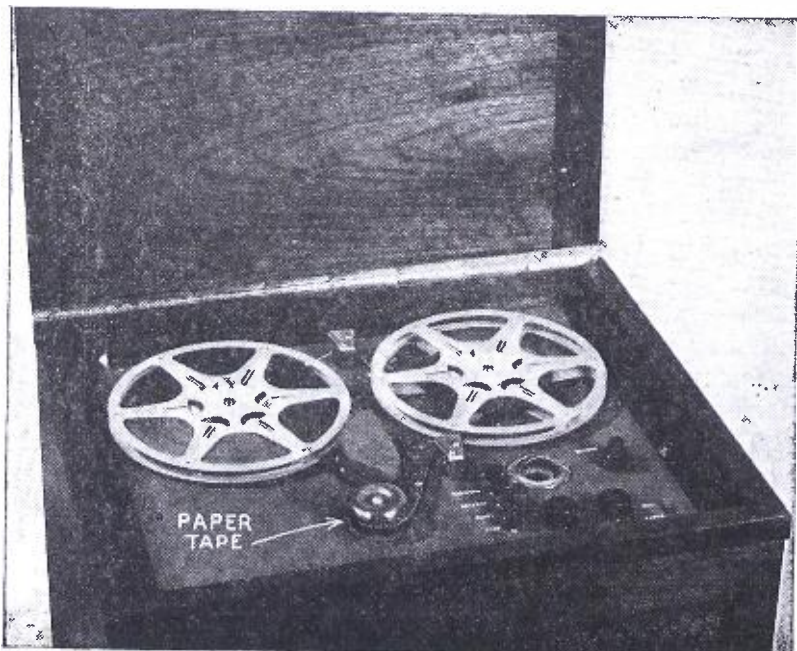



# MONTHLY REVIEW

## to the Technician

**SHORAN**, a radar instrumentality used during the later stages of the war, may be used by geographers, reported its inventor, Stuart W. Seeley of RCA, speaking to the American Institute of Electrical Engineers at its winter meeting. As a radar "yardstick," it can measure distances up to 250 miles with almost pinpoint accuracy.

"The use of blind Shoran bombing over the battlefields of Europe," Mr. Seeley said, "showed that it was capable of equalling visual bombing in accuracy under normal conditions and surpassing it when the latter suffered from target identification difficulties. On occasion, rolling barrages of fragmentation bombs were laid down only a few hundred feet ahead of our advancing troops. The demoralizing influence of such a barrage, from planes completely hidden in a clouded sky, was tremendous."

One of the Shoran system's most promising peacetime possibilities was revealed to be its use in mapping vast uncharted areas on the earth's surface. Its accuracy in taking measurements, according to Mr. Seeley, equals that of first order survey work—or an error of only one foot in five miles. It has the marked advantage of completing measurements that might take weeks of painstaking surveys on the ground.

The system operates on what is known as the echo-timing principle, in which distance is measured by the reflection of radio wave pulses, much the same as in radar. But in Shoran the airplane transmits two signals to the two ground stations of the system, where they are immediately transmitted back to the plane along the same path. By automatic measurement of the time required by a radio signal to traverse each round-trip path, the airplane equipment obtains an accurate figure for the distance of the plane from each station.

**A RADIO ROOM** has been donated to the Vaughan General Hospital, Chicago, by the Hallicrafters Co., a last month's report from that city states. It is to be used as part of the veterans' occupational therapy program, giving servicemen patients an interesting outlet for their energies.

The radio room consists of two sections, a repair shop and a code practice department. It is supplied with complete test and repair equipment, work benches, storage cabinets, parts kits, charts and textbooks.

The code room is furnished with code tables, telegraph keys, headphones and an automatic tape machine. The repair shop can accommodate approximately 50 patients at one time, with plenty of seating facilities for veterans.

**RADIO SIGNALS** from the moon were reported January 10 by a group of Signal Corps scientists working under Lieutenant-Colonel John H. DeWitt. The radio signals received did not originate on the moon, but were return pulses of radar transmissions beamed at that body and picked up on the return trip by special transmitting and receiving apparatus designed by the Signal Corps.

The transmitter was very much like a standard war-time radar outfit. Although many components of a regular "SCR-271" set were used, and operated at the standard frequency of 111.6 megacycles, the long range of the "target" made certain deviations necessary. A much longer pulse repetition rate was used, somewhere between 3 and 5 seconds, whereas the usual pulse rate is of the order of thousands of times per second. Also the "pulse width" which in radar parlance means the length of time each separate pulse of energy exists, varied from 1/10th to 1/2 second, an enormously long interval compared to the usual radar pulse width for war purposes, measured in millionths of a second. The electronic transmit-receive (TR) switch was dispensed with for these low repetition rates, ordinary electric relays being used.

Many other problems had to be solved in this investigation. For example, the question of the relative speed of the moon to the earth as it travels across the heavens from rising to setting. Such speed varies from 750 miles an hour *faster* than the earth's rotation at Belmar, New Jersey, to zero when the moon is at its zenith, and then again to 750 miles an hour *slower* than the speed of the earth's surface at that point in New Jersey when the moon is setting.

Such variations were important because of the very special receiver designed to pick up the weak signals from the moon. It was a quadruple

Antenna which sent signals from New Jersey to the deceptively near-appearing moon and back.

superheterodyne with 4 i.f.'s. The lowest and last of these operated at 200 cycles per second. Band pass of the receiver was only 60 cycles. Sensitivity was in the order of .01 microvolt absolute.

The highly selective receiver made the Doppler effect (lengthening or shortening of waves when transmitter and receiver are moving rapidly away from or toward each other) important. The receiver had to be tuned at times to a frequency differing as much as 200 cycles from the transmitted frequency. Calculations as to the relative speeds of the earth and moon had to be made before each attempt at contact, so that the change in frequency could be allowed for.

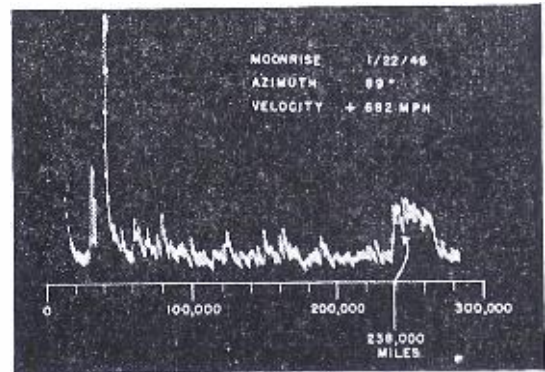

Oscillograph of signal returned from moon. Tall trace at left is direct from transmitter.

A double antenna was used, containing 64 dipoles instead of the usual 32. As the antenna could not be rotated vertically, it was necessary to transmit near moonrise or moonset. Peak transmitter power was three kilowatts.

Lieutenant-Colonel DeWitt, who was an amateur radioist and broadcast engi-

(Continued on page 430)

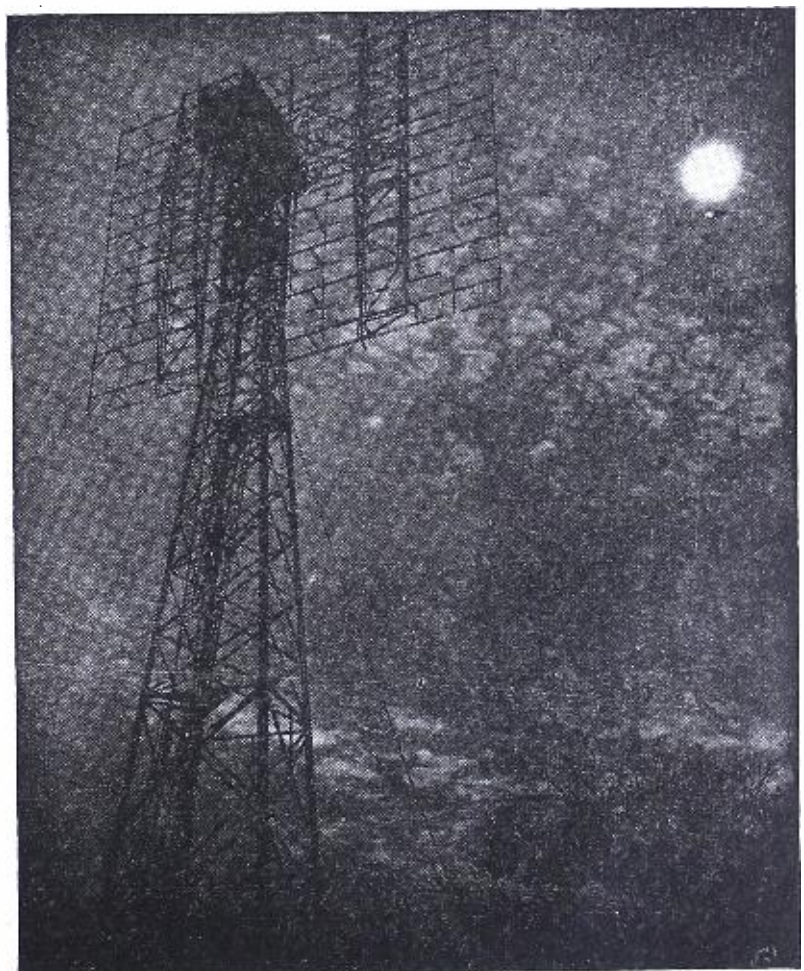



# "VIDEOSONIC" SOUND

## British Television Puts Sound and Sight on One Carrier

**T**HE use of separate sound and vision channels in the transmission of pictures has always seemed to be a temporary expedient in the television art. It is comparable to the early attempts at making talking films in which the sound was

reproduced from a phonograph record synchronized to the cinema film. Nowadays it is found advantageous to record the sound track on the side of the film, thus combining the sound and picture on a single recording medium. In the same way it would be more desirable to make the television sound transmission an integral part of the vision waveform, thus dispensing with the sound transmitter completely. This, as will be seen later, is one of the least important advantages of such a system.

### BRITISH TELEVISION METHODS

To show how the new method works we will describe the scanning sequence of British television transmissions. To be transmitted by radio, a picture must be broken down into a series of component parts which are sent through the ether in an ordered sequence. This process is usually referred to as scanning the picture. To transmit moving pictures it is necessary to send out a sufficient number of pictures or frames per second for the visual impression of one frame to be retained until the next frame is completed. Pre-war British transmissions radiated 85 frames per second and each frame was built up by scanning 405 lines. The pictures were in fact interlaced, every frame being composed of two interleaved scanning fields of 202.5 lines, though this need not concern us in a description of the operation of the system. Thus 405x25 or 10,125 lines were scanned every second and the scanning time for each line

was  $\frac{1}{10,125}$  seconds or approximately

100 microseconds. This time is divided into two parts; a period of 90 microseconds is allowed for the scanning of the line AB, Fig. 1a, during which the output from the television camera (Fig. 1b) depends on the tonal values existing along the line, being maximum for white tones and falling to 30 per cent of the level for black tones. The output from the transmitter, Fig. 1c, is amplitude-modulated in accordance with the tonal values. This period of 90 microseconds is followed by an interval of 10 microseconds during which the scanning spot rapidly returns along the path BC to C, the starting point for the line CD. During this latter period the output from the camera, Fig. 1b, and from the transmitter, Fig. 1c, falls to zero. The Videosonic System recently developed by Pye Ltd., makes use of these gaps in the vision transmission to radiate the sound program. This is done by inserting a pulse into each of the idle spaces, BC, DE, etc., and varying the width of the pulse in accordance with the sound to be transmitted. If the sine wave, Fig. 2, is to be transmitted, the pulses, Fig. 2a, are varied in width cyclically with the amplitude of the modulation. These pulses have a mean width of 3 microseconds and they widen to 5 microseconds or narrow down to 1 microsecond depending on whether the modulation has a crest or a trough value. These sound pulses are shown in the magnified diagrams of the synchronizing intervals, Fig. 2a. The pulses have a peak amplitude of 1.4 times the picture white level in order to facilitate their separation from the picture waveform in the receiver, as this separation is made on an amplitude basis.

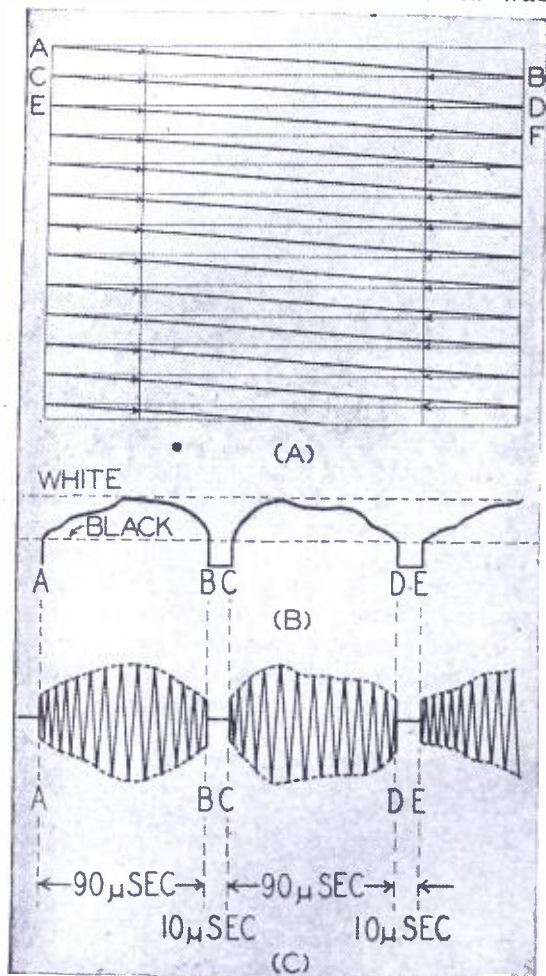

Fig. 1—Television transmission waveforms.

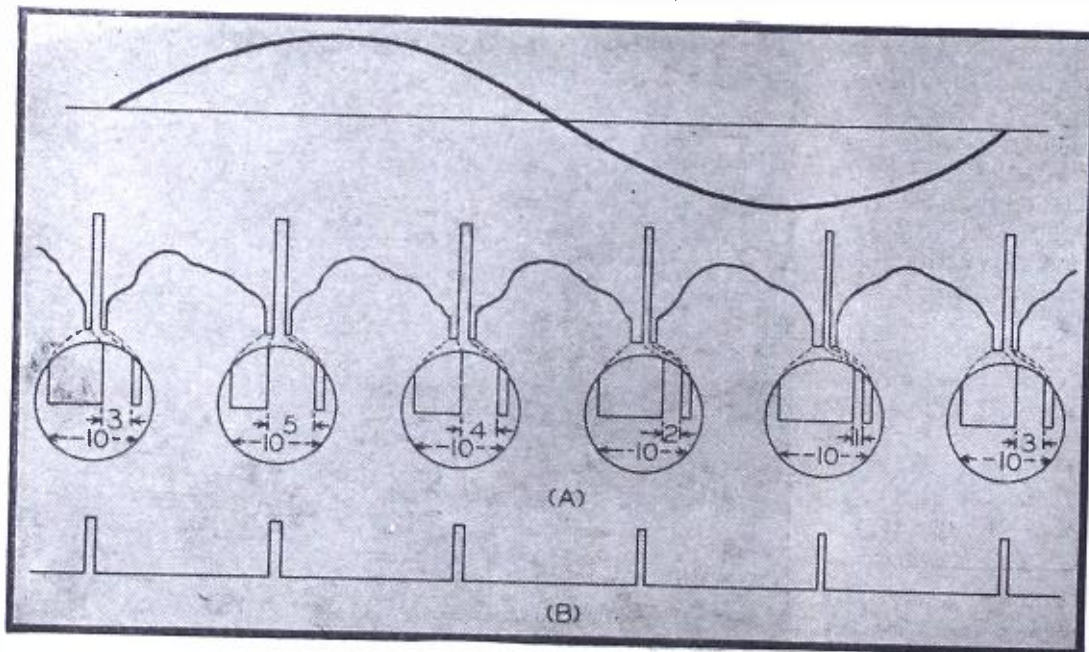

Fig. 2—Sound, represented by top sine wave, is put into pulse form (b) and inserted in gaps between television scanning lines, as shown in magnified portions of the drawing.

### LINE FLYBACK SUPPRESSION

It will readily be appreciated that the sound pulse having this enhanced amplitude will appear as a white line on the flyback traces on the television receiving tube, and the 405 pulses appearing per frame will form a white band down the center of the tube. If the sound pulses making up this band are width modulated then the band will have the appearance of a motion picture sound track. This is shown in Fig. 3, which is a photograph of a picture received on a normal television receiver. To remove this white band from the picture at the receiver it is necessary to provide line flyback suppression. This is done by applying the negative voltage developed across the line scanning coils during the flyback period to the grid of the cathode ray tube. The waveform



presented to the sound unit from the vision received is shown in Fig. 2a and the first step is to separate the vision from the sound waveform. This is done by clipping the sound pulse in a limiting stage; the resulting waveform in Fig. 2b has now had all the picture components removed. The mean level of this waveform will vary according to the sound modulation, due to the variation in the width of the pulses. It might be thought that it would only be necessary to pass the pulse waveform through a low-pass filter having a cutoff frequency just below the pulse repetition frequency to recover the modulation.

This, however, is not quite the complete story, for if (for example) we try to modulate a pulse train having a repetition frequency of 10,000 per second with a tone of say 7,500 cycles, the resulting pulse waveform appears exactly the same as if the modulation tone were 2500 cycles, Fig. 4. In general it can be shown that if the pulses have a repetition frequency  $f_0$  then any modulation frequency  $f_1$  will produce side bands of frequencies  $f_0 \pm f_1$ , as well as the repetition frequency  $f_0$ , in addition to harmonics of these terms. Thus for modulation frequency bands extending beyond a frequency which is given by the formula

$$f_0 - f_1 = f_1 \text{ or } f_1 = f_0/2$$

the lower sideband will fall within the modulation spectrum. The modulation frequency must, therefore, be restricted to one half the pulse repetition frequency. In the case under consideration

the limit would be  $\frac{10,125}{2}$  or about 5 kc.

This limitation of frequency response is the most serious objection against the system as applied to pictures of the present definition. This objection, of course, disappears as we consider higher definition systems, since the number of sound pulses radiated per second would thereby be increased. A 1000-line interlaced television system transmitting 25 frames per second would be capable of reproducing sound frequencies up to 12 kc. Tests carried out in the United

States would seem to indicate that the restriction of the audio range to 5 kc would be acceptable to the large majority of both the critical and non-critical listening public.\*

The sound section of the Videosonic receiver is considerably more simple than the pre-war television sound receiver for amplitude modulation in that it comprises only two tubes, and all the sound radio-frequency circuits have been discarded. The first tube clips this sound from the vision waveform. The second is the output stage of the sound receiver. Frequency-selective feedback is applied to the output stage to reject frequencies above 5 kc. The rejection is peaked at the pulse repetition frequency and at 10,125 cycles the response of the amplifier is 40 db below the program level.

Perhaps the most attractive feature of the Videosonic system is the great reduction in ignition interference troubles as compared with amplitude modulation. Tests were made with a conventional amplitude modulation receiver and a Videosonic receiver, connected to a common antenna. A spark coil was operated in the vicinity to simulate interference. The amplitude-modulated program was completely obliterated, but the Videosonic program was scarcely affected. This is because the limiter stage cuts a slice from the sound pulse, and thus, under bad signal-to-noise conditions, the interference will be limited to the amplitude of the slice cut by the limiter. Under bad interference conditions the signal/interference ratio tends, therefore, to a constant level, independent of the severity of the interference, whereas, in amplitude modulation interference level at the output increases with the input.

\* Chinn and Eisenberg: Total range and Sound Intensity Preferences of Broadcast Listeners, Proc. I.R.E. Sept. 1945.

Fig. 3, below—Waveform of the sound pulses during flyback periods. Right—Photo of the sound waveform generator and mixer apparatus.

Photos courtesy British Information Service

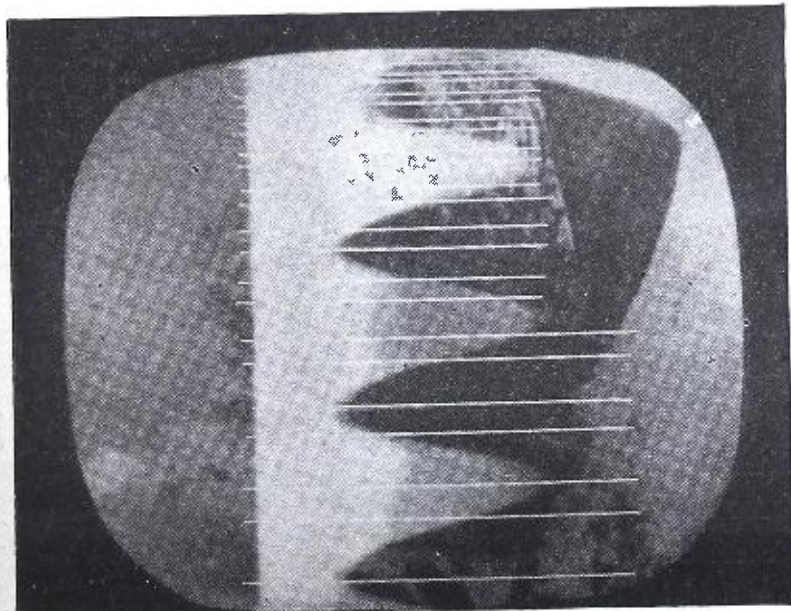

Calculations and experimental measurements show that, as far as fluctuation noise is concerned, there would be little to choose between the Videosonic system (in which the sound impulses which are 1.4 times peak white and, therefore, would correspond to a peak power of 34 kw on the prewar transmission), and prewar amplitude modulation transmissions having peak powers of 12 kw. The pulse transmission actually shows a slight improve-

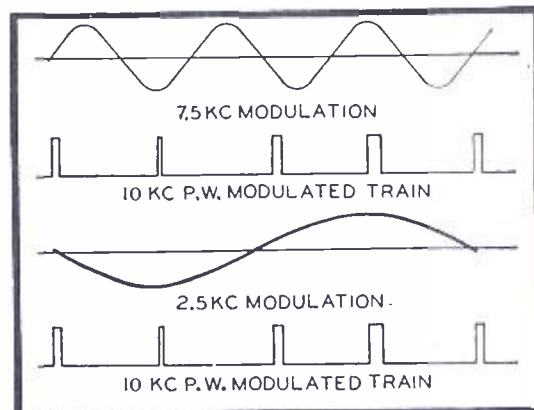
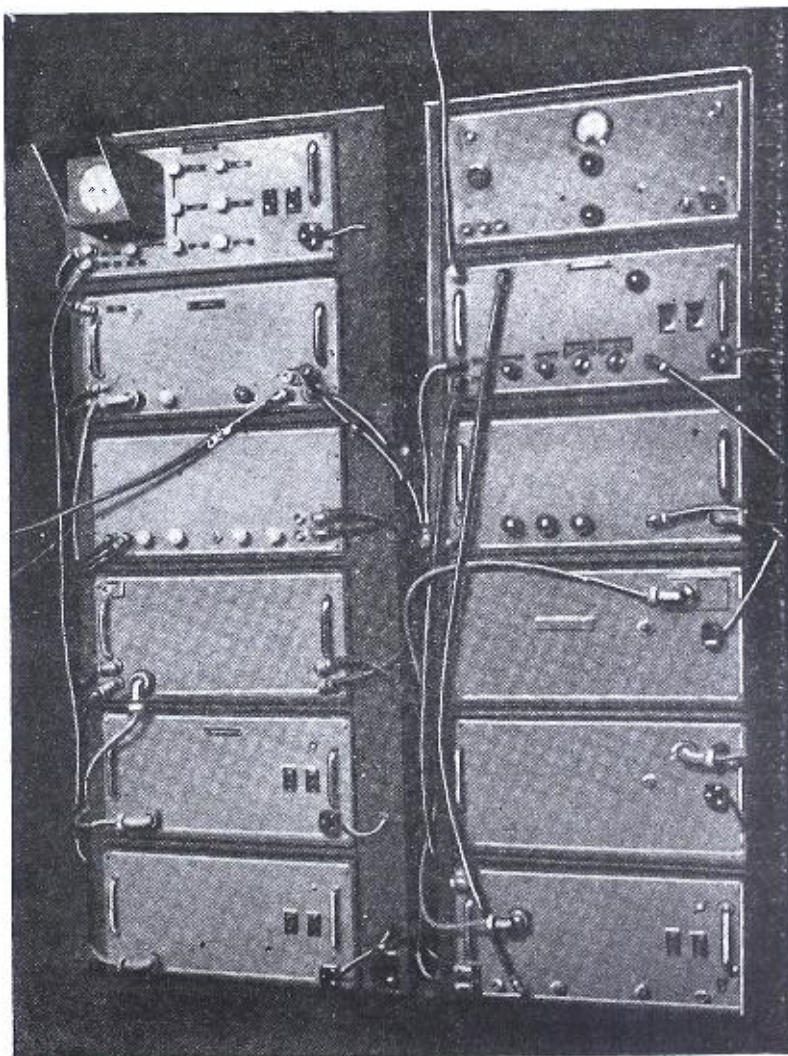

Fig. 4—Similarity of pulse waveforms on application of 2500 and 7500 cycle modulation.

ment (2 db), and theoretical considerations predict that this would increase 3 db if the definition of the system were doubled in spite of the two-fold increase in audio bandwidth.

Another consequence of the receiver operating from a slice of the sound pulse is that the audio output remains constant even though the signal at the receiver is subject to the severest kind of fading.

A further advantage of the Videosonic  
(Continued on page 421)





# H. F. CRYSTAL DIODES

## An Old Friend of the Radioman Makes a Startling Comeback

**T**HE limitations of conventional and even of special types of vacuum-tube diodes make them unusable at the high frequencies used in the most recent radar equipment. It was therefore necessary to develop a new kind of detector for use in the signal frequency sections of u.h.f. and s.h.f. receivers. The answer was found in the crystal diode.

Just a few years ago the crystal detector belonged to the archaeology of radio communications. With the discovery of the remarkable properties of hollow wave guides it was resurrected for use in measuring instruments. As development progressed from the u.h.f. into the s.h.f. ranges, the crystal was pressed into service as a circuit element.

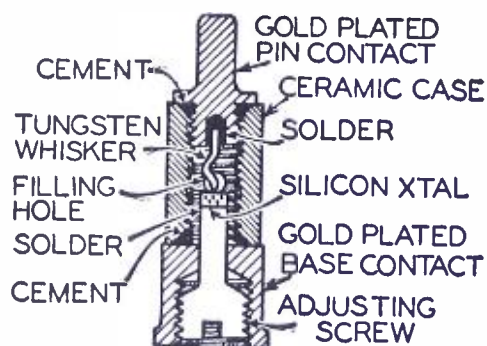

Fig. 1—Modern crystal diode, cross section.

Considerable research and development work was necessary, however, before these units became entirely satisfactory. Photo A shows a typical crystal detector of the first World War period (1919), together with a modern Sylvania 1N21B crystal diode.

### CRYSTAL DIODE THEORY

The present concept of the rectification process is based on quantum mechanics and the modern theory of solids. Without going into detail we may describe the process briefly as follows: When two metals are brought together an electrical equilibrium exists at the point of contact; electrons flow in one direction as readily as in the other. However, when a metal is brought into contact with a certain class of materials known as *semiconductors* equilibrium is not established, electrons flow more easily in one direction than the other, and a potential difference exists between the two materials. When an external electric potential is applied to this junction, the energy either adds to or subtracts from the potential energy of the semiconductor at the junction. Assuming an initial energy difference between the metal and the semiconductor, we see that the effect of the ex-

ternal potential will be to either increase or decrease the total energy difference between the two materials, according to the polarity of the external potential. The effective resistance to the transfer of electrons thus varies with the polarity of the applied potential and rectification results.

### MANUFACTURING METHODS

Manufacture of crystals has been developed to a state of precise process control. Batches of the extremely pure crystalline material, such as silicon or germanium, are melted in electric furnaces together with a *doping ingredient*. In an ordinary chemically pure semiconductor the resistance to electron flow is high in either direction, but by the addition of controlled quantities of other elements the conductivity can be increased. The atoms of these doping elements alter the electronic structure of the semiconductor and reduce the initial potential difference between the metal and the semiconductors.

The melt is cast in ingots. These are sliced into wafers and the surfaces polished to optical flatness. After fragmentation, the minute crystals are mounted by a special soldering technique which avoids rectification at the mount. In the final assembly, an accurately pointed tungsten wire spring is brought into contact with the crystal and adjusted for pressure and sensitivity. Fig. 1 shows the cross section of a crystal diode of the 1N21B type.

The principal wartime use of crystal diodes was as first detectors in u.h.f. and s.h.f. receivers. At these frequencies conventional vacuum tubes are limited by electron transit-time effects.

Velocity-modulated tubes, such as Klystrons, might be used were it not for the extremely high thermal noise which they produce. In a crystal diode the transit-time effect is not a factor. The noise figures are very low and the limiting feature is the interelectrode capaci-

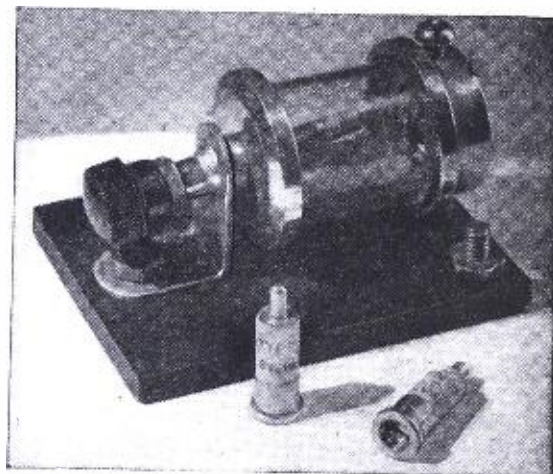

Photo A—Crystals of World War I and II.

tance, which may be controlled to a large extent by proper attention to the geometry of the holder or mount employed.

### MECHANICALLY RUGGED

Crystal diodes are ruggedly constructed. Their resistance to vibration and shock is comparable to that of an ordinary receiving tube. They can tolerate temperature extremes from  $-40^{\circ}$  to  $+70^{\circ}\text{C}$ . Preliminary tests have shown that the units will perform satisfactorily for a period of many years without appreciable deterioration. The principal precaution is to see that the unit is not

(Continued on page 428)

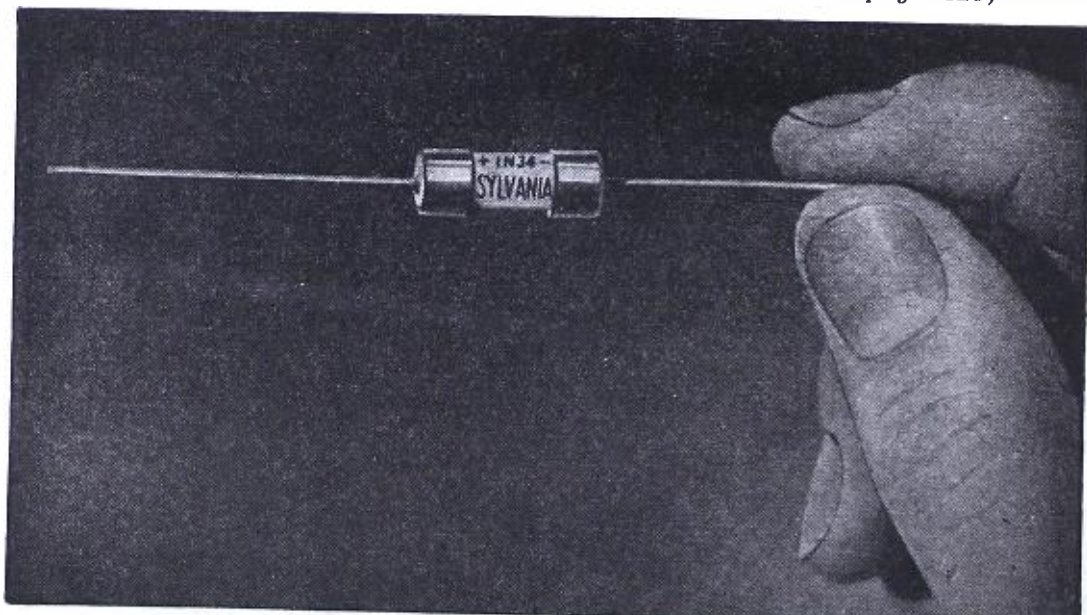

Photo B—The 1N34, one of the latest of the crystal diodes, rectifies currents of 50 ma.

Photos courtesy Sylvania Electric Products, Inc.



# A BRAILLE ANALYZER

*Sighted and Blind Radiomen Will Find It Well Worth Study*

**P**RIOR to the war, a number of blind men and women were interested in amateur radio activity, and quite a few became licensed operators. When Uncle Sam called for manpower to serve on both the battle and home fronts, many of these operators attempted to enlist in the armed forces, but were rejected on the basis that they could not meet Uncle Sam's physical requirements. However, the more technically trained blind found jobs as radio instructors in technical schools and re-

which reading is accomplished is as follows: A buzz is produced in the earphones and the indicator is rotated until a node of silence is found. The reading is then taken from the Braille dial, which is interpreted in terms of the reference value used. For the sake of convenience, the Braille dial has been constructed as shown in the photograph with a double row of dots interlaced so that the hand on the indicator alternately intersects a point on the upper or lower row. For simplicity, three vertical dots are used at each even ten on the upper row with only the first digit of the number involved shown, such as 4 for 40 etc. At each fifth division on the lower row, two dots are used. The tap switch on the left points to a Braille number or character indicating the reference value for that position.

voltage for current calculations; two flashlight cells to provide the current for the reading on the Wheatstone bridge; and a filament control jack. From Photograph B the panel at the center will be seen at the back of an

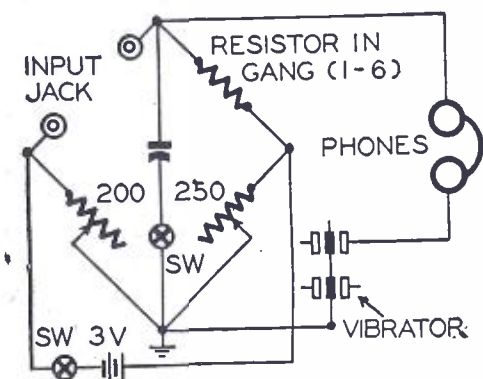

Fig. 1—A breakdown of the ohmmeter section.

search and design engineers in the development and production of radio equipment. Those who had acquired a degree of manual dexterity through the mechanical construction of amateur radio equipment, found their way into factories, there performing a multiplicity of operations.

Both in the operation of amateur stations and the servicing of radio equipment, there is frequent need of knowing values such as current, voltage, resistance and capacity. The average sighted person is able to read these values through the use of a milliammeter or an ohmmeter. It therefore became necessary to find some method by which the person with insufficient or no vision could determine these same values.

Several methods and principles were adopted by different workers. The most desirable of these have been incorporated in the instrument herein described. We choose to call this a Radio Analyzer since in its present form it is quite useful to a blind radio serviceman, enabling him almost instantly to find any defect in a receiver. The analyzer has been constructed in a small unit as shown in the accompanying photograph so as to be portable and to be quite elastic in application. (Photo A.)

This instrument is essentially a Wheatstone bridge, used for the measurement of resistance or capacity, and an ammeter. Voltage is read by the addition of series resistors. The method by

## CONSTRUCTION

Photograph A shows the panel placed at an angle. This facilitates reading the dial and the manipulating of the various switches. The box is seven inches wide, six inches long, two inches high in the front, and five and one half in the rear. This provides space, as will be seen from the inside view, for a No. 6 dry cell (to excite the automobile type 2-volt vibrator seen next to it) one flashlight cell used as a standard

W. S. Wartenberg was born in 1907. Due to lack of vision, he entered the Institute for the Education of the Blind in 1915. In 1918, while a member of the Junior Boy Scouts, he built a primitive wireless set—but it did not work! After spending much time and effort talking to people regarding this instrument, he finally got it operating in 1920.

Continuing his interest in radio, he obtained his ham license in 1930. Now operates on 10 meters with the call W2ET, using a pair of 809's push-pull feeding into a one-half wave doublet with co-ax. Receiver is a Super-Pro. In the old days operated on 20 meters with cw and phone. Follows with great interest the progress and work in ultra-short waves.

He is Supervisor of Employment at the Federated Institute of the Blind. At present is assisting in the invention and development of electronic devices which he hopes will some day be helpful to the blind.

old fashioned General Radio potentiometer. It is highly important that this be linear since the scale is linear. Several modern commercial potentiometers tried were found to have various types of curves which distorted the reading at either end of the dial. Therefore, we

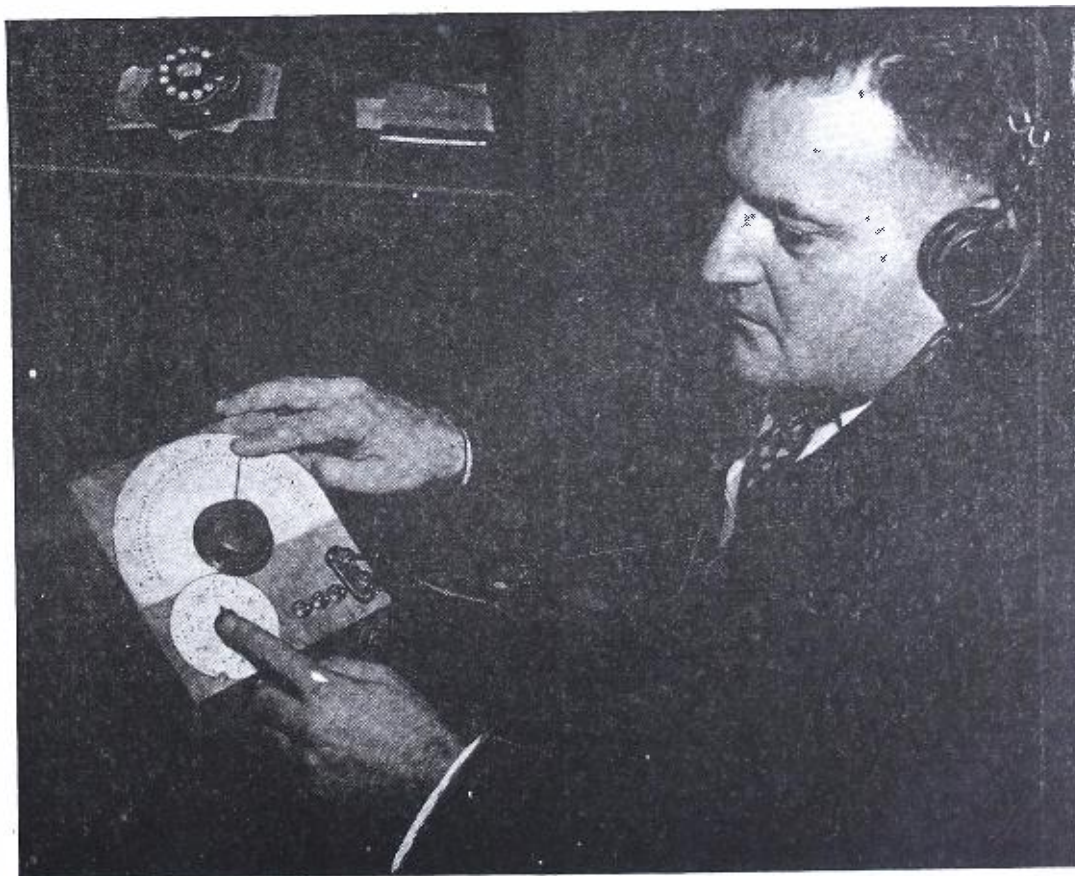

Photo A—Mr. Wartenberg and his instrument, showing the Braille dial markings.



dug deep into our junk box and found this relic which fills the bill most adequately. The movable arm rotates a total of 270 degrees, 180 of which are used for a full scale reading. The remaining portion of the arc, although not calibrated, is useful to determine if the unit being tested is larger than the reference value against which it is being checked. Approximately 200 ohms of the potentiometer constitute a full

100-, 10-, or 1-ohm resistor. The values are placed individually across the binding posts shown at the right front of the panel. With the tap switch in this position, the analyzer becomes an ammeter. When 1 ohm is brought into the test circuit, the full scale reading is one amp. The other resistors will make the reading 0-100, or 0-10 milliamps, or 0-1 milliamps when the 1000-ohm resistor is employed in the circuit. Another

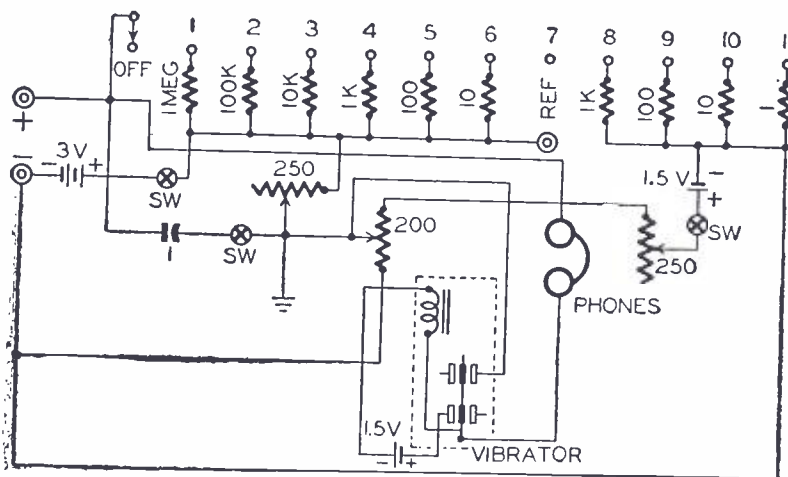

Fig. 2—Schematic of the combination acoustic ohmmeter and analyzer.

scale reading of 100 on the dial. A similar value of resistance, (actually a 250-ohm potentiometer), with screw driver adjustment, balances this portion of the bridge. See Fig. 1.

An 11-point tap switch with one megohm, 100,000 ohms, 10,000 ohms, 1000, 100, and 10-ohm precision resistors are used as reference values when the analyzer is employed as a Wheatstone bridge. A seventh point on the switch makes it possible to connect reference capacitors to check condenser values. These must be read in a reverse direction on the Braille dial as increasing the scale reading increases the resistance in the circuit and the capacitive reactance increase is inversely proportional to the capacity. Fig. 2 is a complete schematic. When reading capacitance it is necessary to replace the d.c. supply across the bridge with low-voltage alternating current.

As we rotate the tap switch to the following 4 positions (8, 9, 10 and 11), it introduces into the circuit a 1000-

100-, 10-, or 1-ohm resistor. The values are placed individually across the binding posts shown at the right front of the panel. With the tap switch in this position, the analyzer becomes an ammeter. When 1 ohm is brought into the test circuit, the full scale reading is one amp. The other resistors will make the reading 0-100, or 0-10 milliamps, or 0-1 milliamps when the 1000-ohm resistor is employed in the circuit. Another

screwdriver adjustment potentiometer is used in series with a G.R. potentiometer so as to place 1 volt across the used portion of the potentiometer at a reading of 100. The action may be understood from Fig. 3.

### ACTION OF THE VIBRATOR

The vibrator used is a type that can be excited by 1 or 2 volts, and therefore, the No. 6 dry cell seen in the second photograph is sufficient. The armature customarily used to rectify high-voltage supply in the automobile radio power pack is used in this case to cut the phones in and out of the circuit which actually produces the buzz heard in the earphones. When used as an ammeter, the movable arm of the G.R. potentiometer is adjusted so as to equalize the voltage developed across any reference value brought into play by the tap switch. The vibrator rapidly connects and disconnects the phones across these two points, namely, the potentiometer arm (plus) and the plus side of the reference resistor. It will easily be seen that when the arm is at too low a value the phones will receive plus voltage from the reference resistor and when too high, plus voltage will pass through the phones from the standard cell. In these two latter instances a buzz will be heard in the phones, whereas when the voltages are equal across the phones, there

will be a node of silence. The 1- $\mu$ f condenser is switched in on high-resistance readings to build up the sound in the phones.

When the analyzer is used as a Wheatstone bridge the phones are connected in and out of the circuit at the opposite corners of the bridge to the polarizing voltage. When the circuit is balanced through the adjustment of the main dial, the buzz disappears from the headphones as no voltage appears across the bridge.

To read voltage, suitable known resistors are connected in series with the analyzer used as an ammeter. If the scale of 0-1 milliamp is brought into play, only 1 mil is necessary to give a full-scale reading, and as 1000 ohms per volt, this unit becomes a highly sensitive volt meter. Both alternating current and voltage can be read by connecting a fixed crystal detector in series with the phones and calculating 70% of the value indicated on the Braille dial as the analyzer measures the peaks of the applied voltage.

### OTHER APPLICATIONS

In the foregoing there is no new principle or new application of old principles involved, but through the introduction of an accurate Braille dial and the

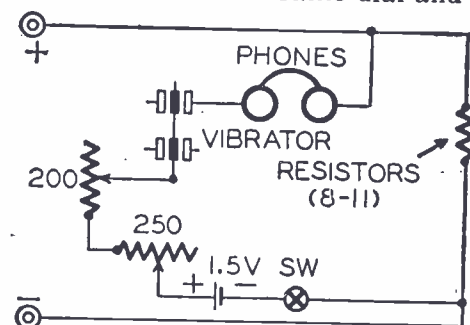
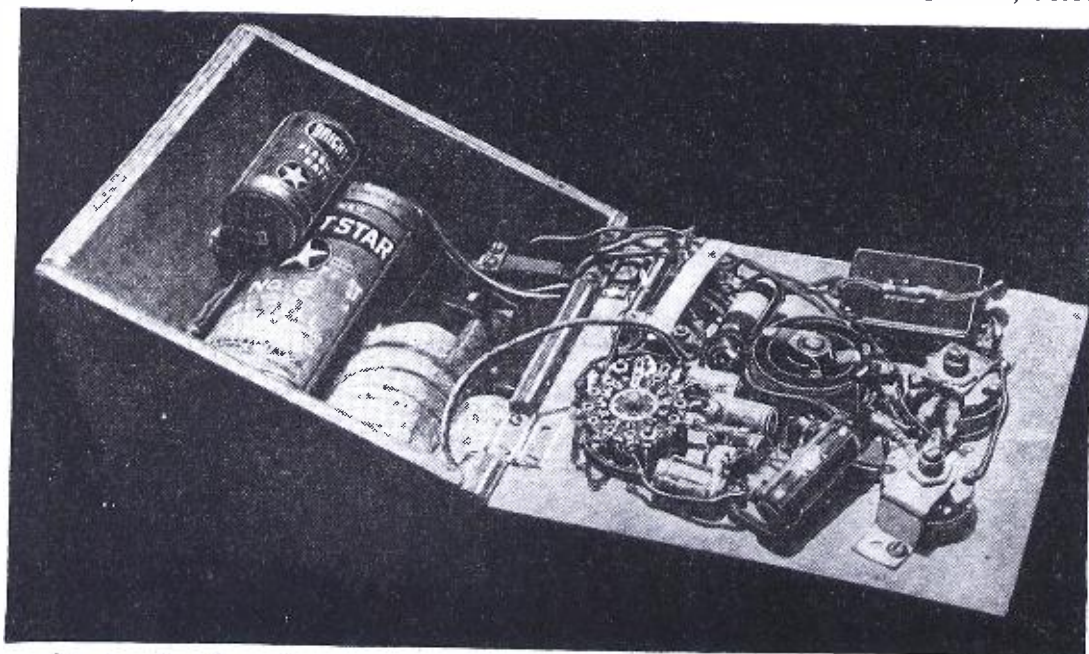

Fig. 3—Breakdown diagram of ammeter section.

buzz produced by the independent armature of the automobile vibrator, a new, sensitive, and accurate instrument has been evolved. There are undoubtedly many other applications in industry and otherwise where these principles would make employment of the blind worker possible. The writer has already constructed a vacuum-tube voltmeter where the voltage developed across the plate resistor is measured against a standard cell in a manner similar to the analyzer described herein, also a field strength meter could be devised where the voltage change in the plate circuit could be measured and interpolated through a node of silence to indicate the point on the Braille dial at which the reading should be taken. One might conceivably construct a galvanometer on this same principle. The writer has already measured with amazing accuracy one one-hundredth part of a milliampere with this instrument which cost but a few dollars to construct, whereas a commercial meter capable of such minute reading is quite expensive. We plan our postwar transmitter to have a suitable value resistor in the negative return of each amplifier circuit so that with the swing of the dial and a flip of the switch, we can instantly read the current at any point in the rig.



Interior of analyzer. Large potentiometer is at center, the screwdriver variables at right.



# POCKET RADIO WATCH

## Miniature Radio Receiver Provides a Constant Time Check

**A** MINIATURE receiving set capable of telling you the correct time and also giving the latest weather report, latest news, and sports results at the flick of a switch or the push of a button, has been announced by Electronic Time, Inc., in a statement filed with the FCC. The new miniature set is about the size of half a pack of cigarettes and, (synchronized with WWV), will give you the correct time with better than ten microseconds accuracy.

Broadcasting of time has been commonplace for navigational and scientific purposes in the past, and present broadcasting stations give the time and time signals on the hour, half- and quarter-hour. Such broadcasting does not give the time when it is wanted, on an uninterrupted schedule. In some parts of the country you can call a number and obtain the correct time for the price of the call, but this isn't always convenient or practical.

### BROADCAST TIME SIGNALS

The National Bureau of Standards station (WWV) broadcasts time signals by means of a tone beat or musical pitch. This service is indispensable for certain fields. The proposed new service would augment it to give the public the same accurate time in readily understandable form. Small, fixed-frequency receiving apparatus can now be furnished to the public at a price below that of good watches, making it economically possible to furnish such a time system. Several different types of small portable sets using the new small hearing-aid type tubes and batteries have been developed recently.

Electronic Time, Inc. intends to broadcast time from a transmitter located centrally in Manhattan at a height of approximately 700 feet (top of the Lincoln Building). The station will broadcast continuously 24 hours daily, using a wire recorder synchronized with the Arlington time signals so that accurate time will be available in the New York area to anyone carrying the fixed-frequency receiving set or having home or office sets. A weather report at intervals will be given with the time during the morning, and sporting events or news of national importance in a concise form during the day.

A poll of numerous individuals suggested that the public does not want to wait for the beginning or end of a typical commercial broadcast to obtain the time. The poll showed that a broadcast such as "The time is ten-thirty" or "Ten-thirty and one-quarter—Rain to-

night" or "11 o'clock—House passes bonus bill"—is most acceptable to the public. Arrangement will be such that the news broadcasts will not interrupt the time broadcast more than a few seconds except in case of national or local emergency when a continuous announcement (such as an air-raid warning) would be of greater benefit to the public.

The company believes that advertising can be so planned that the service will pay without being annoying to the user.

The company has already developed three receiving units on a frequency fixed only to this station. One is a portable unit about half the size of a package of cigarettes; another a desk or office set measuring 3x2½x2 inches; the third is a home unit containing the desk set and equipped with automatic reception at a pre-selected time through the use of the Telechron electric radio-switch clock, which also allows the unit to be used as an alarm clock. Radius of broadcast reception will be about 25 miles. The temporary operating frequency will be between 25 to 30 megacycles, with a power output of two kilowatts using voice emission. The receiver circuit will be a one or two-tube super-regenerative circuit.

It is interesting to note that this swing to an acoustic method of getting the time is not new. Some very old watches (called repeaters) used to operate in an analogous manner. When a button was pressed, they would ring out the hour, then the quarter, or even a smaller unit. The new device resembles the old repeater, of course, only to the extent that a broadcast receiver resembles the music box which was popular at the time the repeater watch was in vogue.

Although the habit of glancing up at a clock will not be entirely eliminated with the introduction of this new gadget, a large market, originally the outlet for electric clocks, will be diverted to these receivers. This system would also be of great benefit to the blind who are limited today to a Braille watch.

### ACTIVELY PROMOTED

The companies actively interested in the project and expecting to participate in manufacture or sale of the instruments include such names as Raytheon, Belmont Radio, and a number of drug-radio-store chains. The estimated retail sales prices for this unit are:

Portable unit .....	\$ 5.00
Desk-Office set .....	5.00
Home unit .....	10.00

According to estimates in the trade, other small portable sets which can be tuned to receive standard broadcast, vary in price from \$15.00 to \$45.00. These can also have a fixed frequency unit, or can have another band tuned to the operating frequency of the time signals.

Batteries that will be used at present are the Eveready Mini-max "B" battery, or similar types in conjunction with the pencil-type "A" cells. The P. R. Mallory Company has been developing a new type of mercury battery which has an especially long life, thus making these and other types of portable units more feasible.

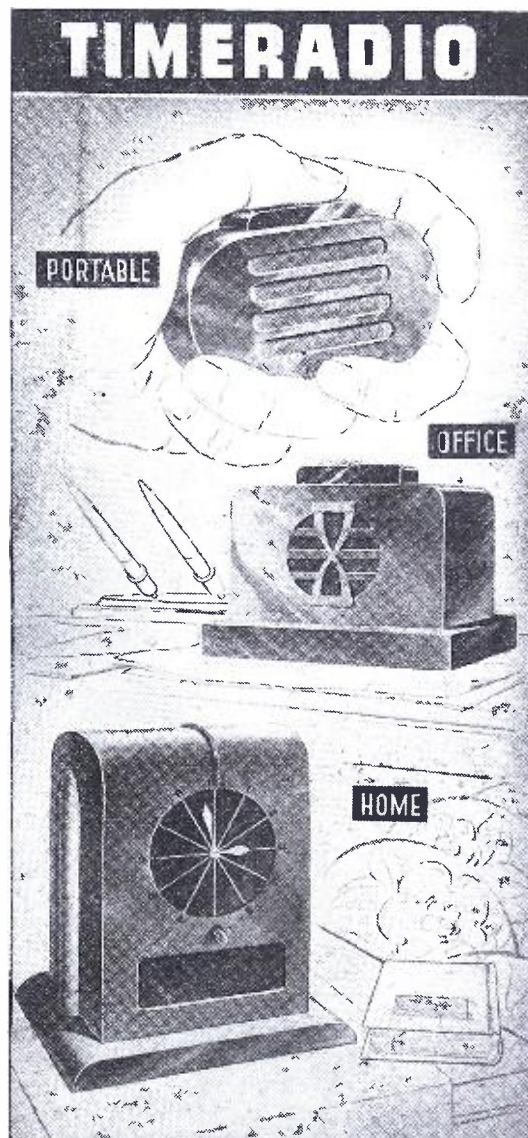

Artist's conception of the Time Radio. The portable or pocket type at top tells the correct time whenever the top bar is depressed. The somewhat larger office model (center) operates in the same manner. The home type (bottom) has a switch so that it can be silenced, operating as an ordinary electric clock, or can repeat the time at intervals (for the benefit of a person within earshot but not in sight of the electronic timepiece).



# ANTI RADAR EQUIPMENT

**T**HE genius of America's big transmitter manufacturers—now engaged in producing new high-power, high-frequency equipment for FM, television and communications use—was devoted up to a few months ago to producing very similar transmitters for the purposes of electronic war. The radar jamming transmitter shown on our cover contains many of the features required in peacetime u.h.f. apparatus. A product of General Electric, it is known as the TDY-2.

Unfortunately, the military use of the apparatus prevents—even at this late date—publication of facts concerning the exact power or frequency of the transmitter, though the magnetron tubes used by it give the reader a rather good idea of the latter. In all the pictures of the apparatus yet released, the top shelf, which carries the power oscillator and modulator, is modestly closed.

The more prosaic power equipment may be seen in the accompanying Photo A. The four tubes which are visible on the top shelf of the lower section are high-voltage rectifiers. Transformers, chokes and other heavy equipment are on the bottom shelf. The

water pump, used for cooling, may be seen behind the engineer's arm.

A special antenna which permitted rotation in any direction, as well as variations in vertical polarization, was used with this unit. A special "antenna pedestal" was required, this consisting of a lower stationary part, and the rotating mast which carried two antennas. The pedestal control-indicator unit both rotates the antenna mast and indicates the bearing in which jamming signals are transmitted.

Another important part of the anti-radar campaign consisted of detecting and locating enemy stations, both mobile and fixed (so that jamming signals could be accurately beamed on them). This device, a great improvement on standard pre-war direction finders, used a cathode-ray indicator like that in a radar set itself.

One of these direction finders, manufactured by the Submarine Signal Co., of Boston, Mass., is shown in Photo B. It measures the frequency of the signal as well as the direction from which it came, and could receive successfully even the ultra-high-frequency signals produced by the very latest radar apparatus. Other apparatus of the

radar counter-measures room, seen around the direction finder, consists largely of receivers tuned to different portions of the radio spectrum.

Operators handling the new direction finders became so skilled that they could look at the scope and tell from the image of the intercepted signals what kind of radar had produced them. It was possible to distinguish between images caused by anti-aircraft, surface search and gun-control radars. Thus in many cases it was possible to deduce the size and class of the ship carrying the intercepted radar. Patterns on the screen when one signal, and when several signals on the same frequency, are present, appear in Photos C and D.

This capability of occasionally identifying the source of signals was at times embarrassing to the operators of the radar-finder. In one case during night maneuvers aboard a destroyer, signals were picked up which could be definitely identified as coming from a U. S. cruiser. This was accordingly reported to the bridge. When, some days later, U. S. cruisers were sighted, the captain felt that his direction-finder men had not been "on the job" because the cruisers' presence had not been detected!

Other apparatus which was developed during the war but which is likely to

(Continued on page 417)

Photo courtesy General Electric Co.

- A—Ultra-high-frequency anti-radar transmitter partly open to view.  
B—Direction finder, center, in an array of anti-radar apparatus.

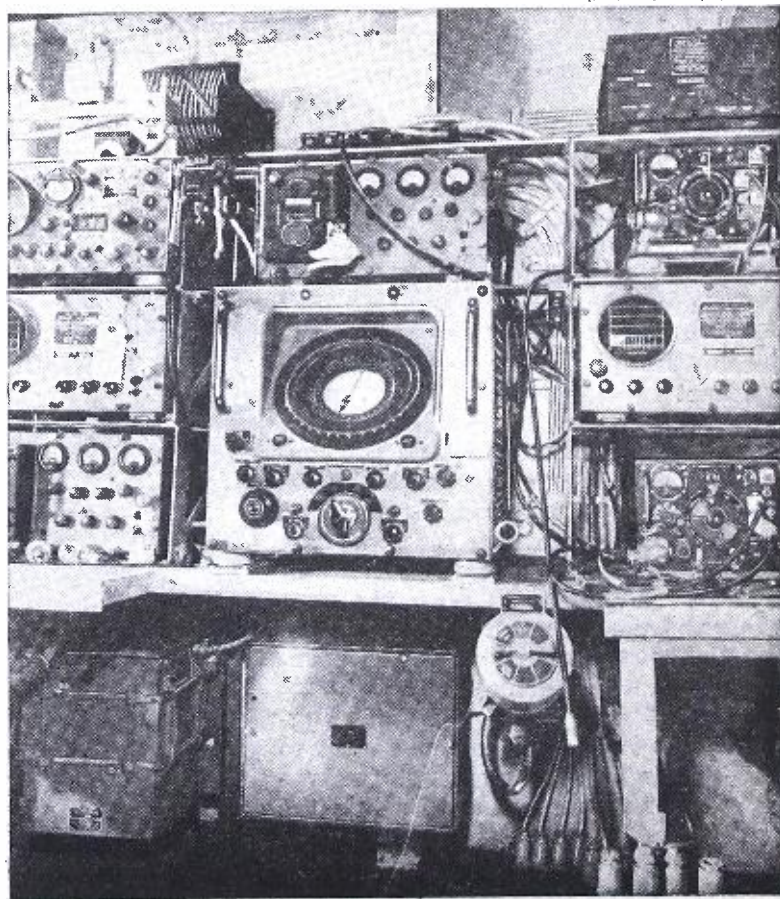

Official Navy Photo







# RADIO HEARING AID

**Now—A Combined Hearing Aid and Miniature Pocket Radio**

**T**HE vacuum-tube hearing-aid is essentially an audio-frequency amplifier where a compromise has been reached between the performance, the physical size and the weight of the component parts. Frequency distortion is purposely introduced to compensate for the uneven pitch sensitivity of the ear of the wearer. This compensation also takes into consideration whether the acoustic conduction is through air or through bone.

Commercial hearing aids use two-stage, or more generally three-stage amplifiers. This gave us the idea of utilizing the same tubes and component parts for radio reception. After some experiment, the circuit shown at the bottom of the page was adopted, and gives good results in both capacities.

The positioning of a switch transforms the set from a hearing-aid to a ra-

dio receiver embodying the audio-frequency characteristics of the hearing aid. A third switch position where the instrument performs simultaneously as hearing-aid and radio-receiver is also mandatory. This enables the wearer to hear conversation while listening to the radio.

The fact that a hard-of-hearing person can in all privacy enjoy broadcasts while sitting at his desk or walking in the street may have a moral value and also a social value. We hope that some technical reader may benefit from it for his personal use.

For the best performance, the circuit has to be individually "fitted" in so far as audio-frequency is required; damping that portion of the range where the defective ear is most sensitive. Fig. 1, the schematic, appears at the bottom of this page. The superheterodyne circuit has been chosen, incorporating necessary modifications to amplify simultaneously at i.f. and a.f.

"Slug" or permeability tuning instead of variable condenser may be preferred because of compactness and reduction of weight. Our apparatus is not exceptionally compact or lightweight because it was assembled with parts available on the radio market at the time. To reduce the dimensions every

Angelo Montani—Age 32. Received his B. S. and Ph. D. at the Royal University of Genoa (Italy) where he was also assistant professor until 1939 when he left voluntarily because he was an anti-fascist. In the United States continued his technical activities as a researcher and consulting engineer.



Published a radio handbook at the age of 19. Has inventions relating to telephony, radio and photographic optics and electron tubes.

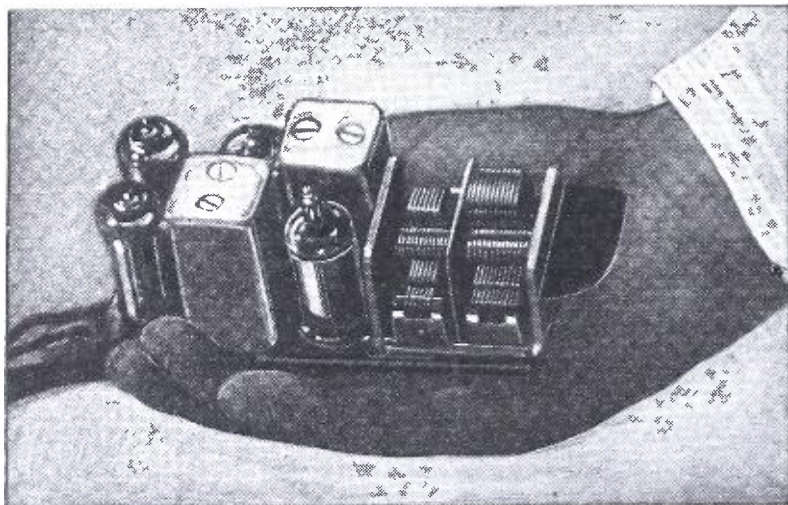

A midget of midgets—the radio hearing aid is just a small handful.

component part should be redesigned. The body of the wearer acts as a capacity-coupled antenna. A loop of wire stretched inside the belt of the carrying case forms one element of the input condenser.

Several constructional difficulties were encountered with the wiring. Feedback from the audio-frequency grid leads is the most troublesome. The a.v.c. is also a source of trouble and although represented in the schematic for sake of completeness, was eliminated in the model shown in the photos. The a.v.c. voltage

(Continued on page 438)

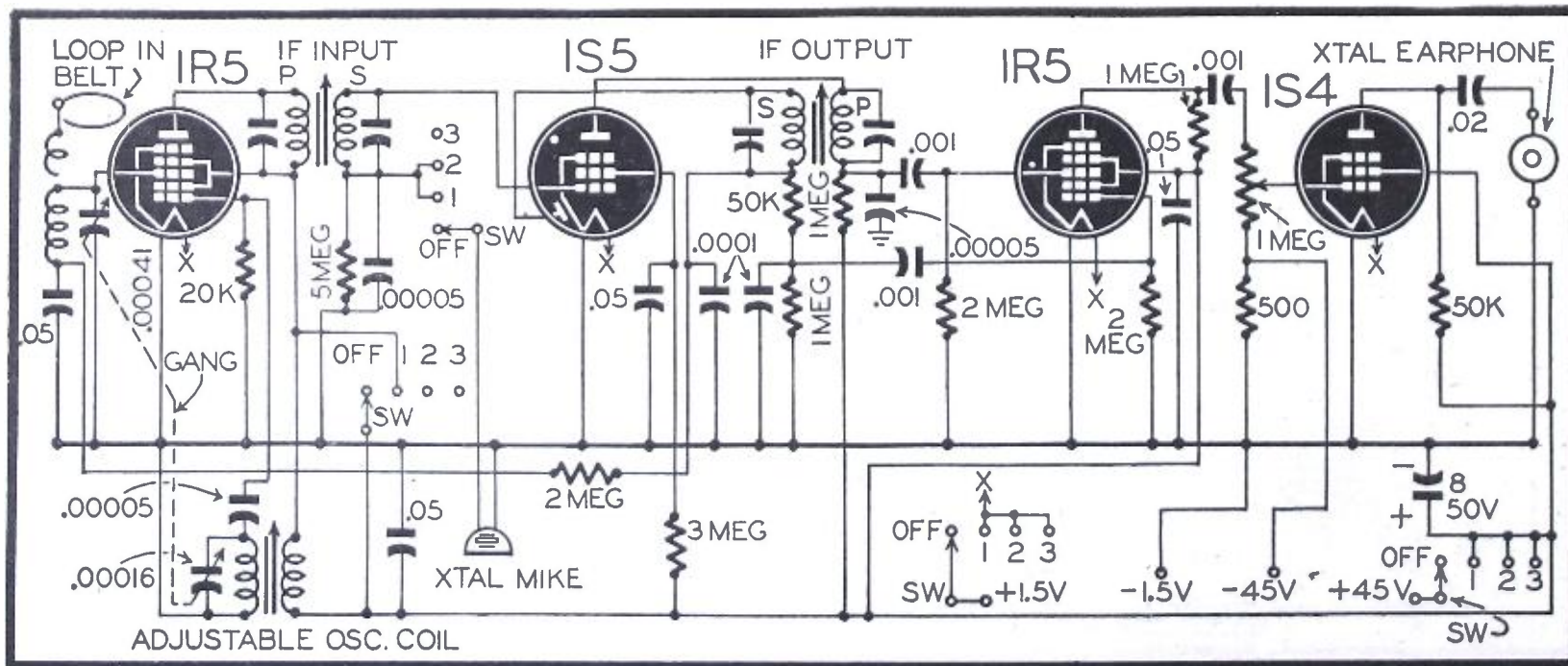



# SENSITIVE TRACER

## For Servicemen Far From High-Power Broadcast Stations

**B**ECAUSE of the distance from powerful broadcast stations at this location, many signal tracers are not sensitive enough to give a positive indication when applied to the antenna or first stage of a radio receiver. This tracer was built with the idea of getting a stronger signal and has given satisfactory service for two years.

Standard practice has been largely followed. Switch 1 at the input tunes that stage roughly to i.f. or r.f. It also has a position for antenna, providing a source of modulated signal where needed.

Practically all radios near here have intermediate frequencies falling between 440 and 480 kc. The i.f. range was set for these frequencies, no provision being made for the few receivers which use 175 kc. Adjustable Meissner iron-core r.f. coils and 365- $\mu$ f tuning condensers were used for the r.f. circuits, and by shunting these with small padders it was possible to tune across the selected intermediate frequency band very nicely. A push-pull wave-change switch out of an old Victor radio was used for this purpose.

It is possible that if old-style 500- $\mu$ f tuning condensers could be obtained that

the padders could be dispensed with, although there has been absolutely no trouble with the present arrangement.

### CONSTRUCTION DETAILS

To get the required sensitivity, three tuned stages were needed. Shielding was also necessary to prevent oscillation, as were the 15,000-ohm resistors across the first two primaries. If two tuned stages are used, there is no tendency to oscillate and there will be enough gain for most applications.

The oscillator section is simple and of standard design. The coils, switch and tuning condenser for it were salvaged from an old Philco radio. The primaries were removed from the coils. This section is the least used part of the instrument, but proves its worth in locating intermittent troubles.

Probes for the r.f. and oscillator sections are made from Belden microphone cable with tiny capacitors near the point of the prod. These capacitors are made from two small strips of copper overlapping each other a quarter of an inch and dressed down to go into the probe. About 30 inches is fine for cable length.

The vacuum-tube voltmeter needs no explanation. The cable for this part of the instrument has a 1-megohm resistor

near the prod point. Sw6 selects the voltage range. The 1000-ohm control used for the volts scale must have a linear taper. Its pointer is the center one on the panel. The scale was made from Bristol board and calibrated by using a power pack and voltmeter. Zero is in the center. The zero setting is made with the 100-ohm wire-wound variable resistor in series between ground and center-tap of the high-voltage winding (the most negative point in the power circuit).

### THE TWO MAIN RANGES

Dial scales for the r.f.-i.f. and oscillator condensers were also made of white Bristol board. They were calibrated with the help of a signal generator and broadcast stations. The left-hand dial, which controls the r.f.-i.f. gang, has the padder switch mounted above and slightly to the right. When it is in the "out" position, the instrument tunes over the broadcast band. In the "in" position, it tunes intermediate frequencies. The padders can be seen mounted above the gang, in the rear-view photograph. The dials are of the large 2 1/16-inch type with celluloid pointer. These look very well, and the hair-line makes accurate readings easy.

The front panel was made from 1/8-inch sheet aluminum. It is 12 inches high by 18 wide, with the 5-inch speaker mounted as shown in the photos. The chassis is 10 x 17 x 3-inches, which is about the right size to mount the parts. Standard phone jacks and plugs were used on the ends of test cables.

The various controls may be seen from the photo. The four electron-ray tubes are lined up along the top, the indicators reading from left to right: r.f.-i.f.; a.f.; v.t.v.m.; oscillator; with the speaker in the center. The pilot light is directly below with the on-off and speaker switch on either side of it. Farther down is the pointer and scale for the v.t.v.m., with its zero-set adjustment on one side and its range switch on the other side of it. The two pointers

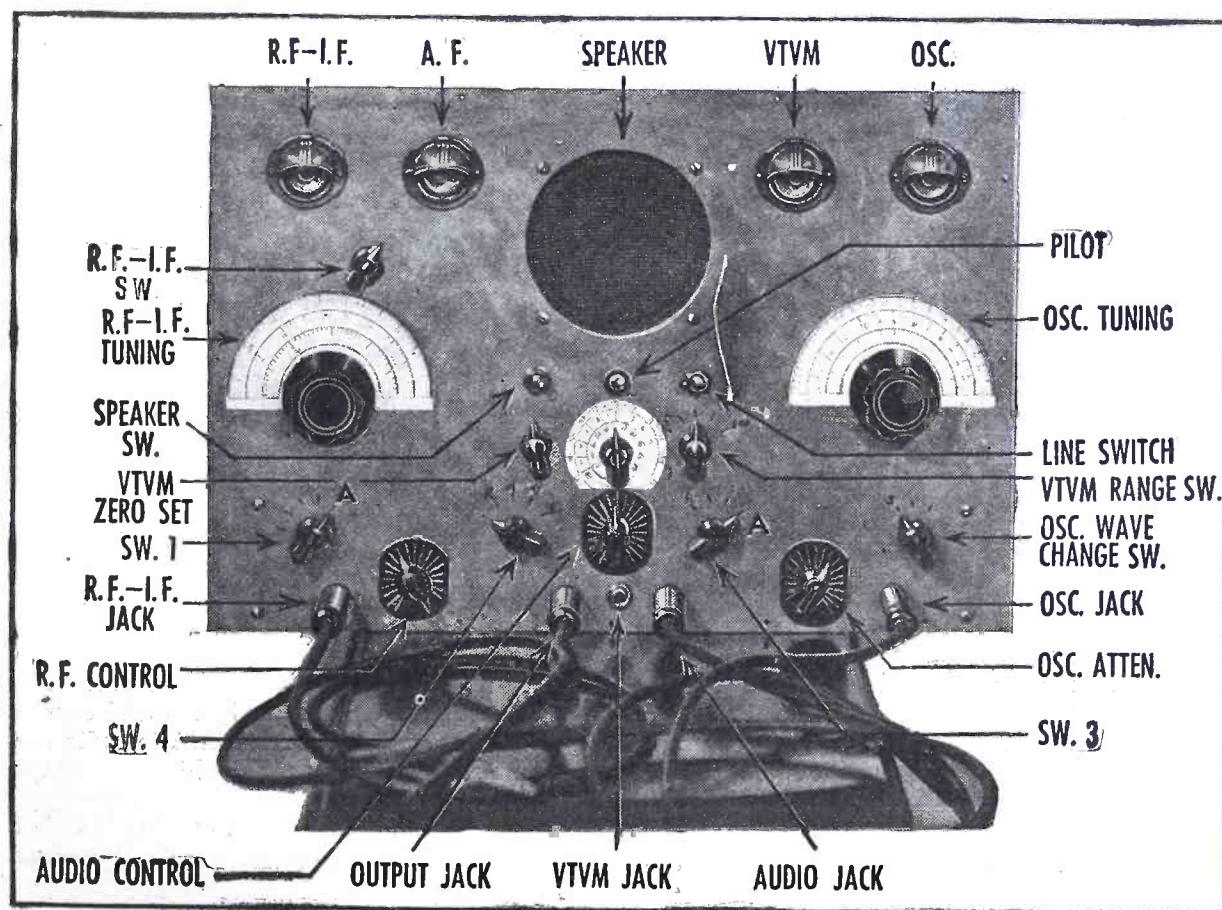



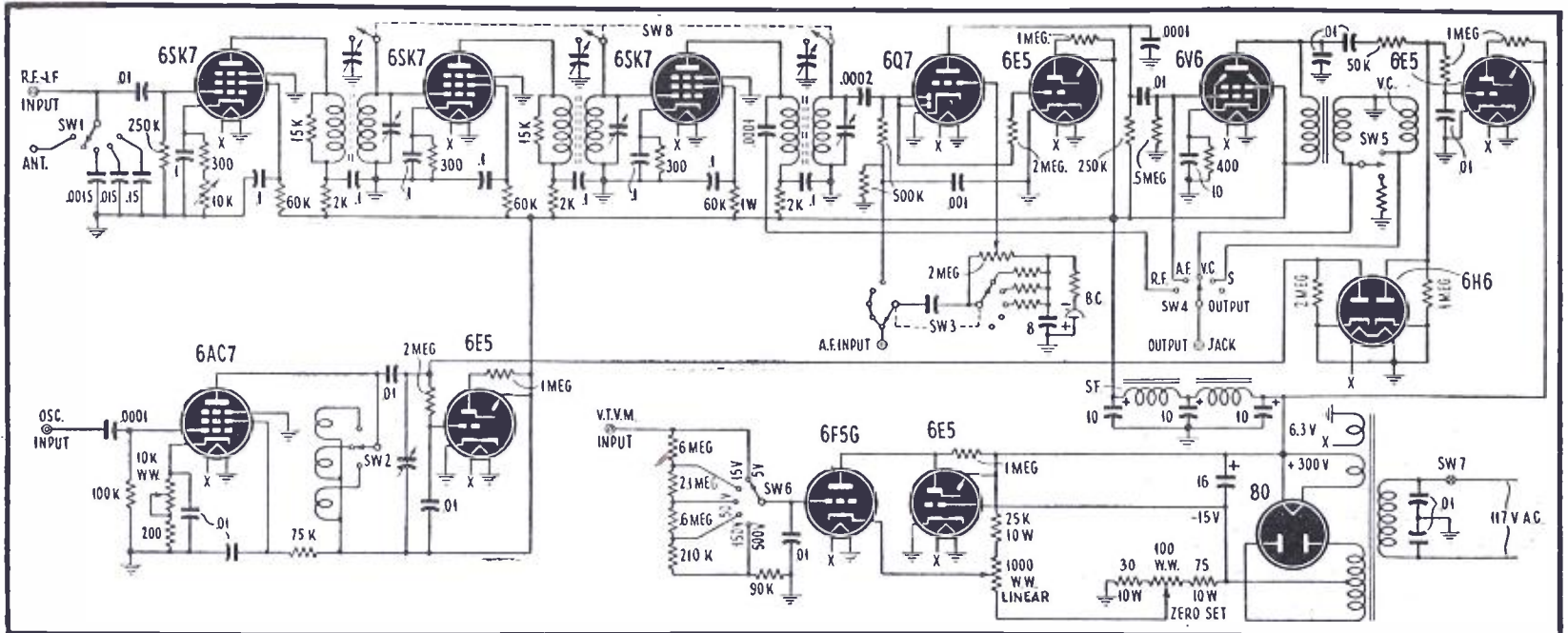

Complete schematic of the sensitive signal tracer. Resistor and condenser values at Switch 3 are explained in note at end of text.

and scales at either side of the panel are the r.f.-i.f. tuning, and the oscillator tuning scales. At the bottom of the panel, reading from left to right (in a staggered line) are the antenna switch

Sw 1 is marked with a large A. The same A (this time for Audio Input) appears on Sw 3. It indicates the full-volume position of the switch, when the volume control has no signal-reducing shunt resistors in parallel with it.

this and any comparable tracer, and a standard work on signal tracing equipment and methods will cover all points that might be raised in connection with this piece of apparatus. The instrument is adapted to use as a multi-channel signal tracer. Clips may be attached to the cables and connected to several parts of a set at the same time. (Note that though the diagram shows standard post-and-ground symbols, these are jacks in the actual instrument, and the ground is made to the shield of the probe cables.) The radio may be left to play till it stops by itself. The eye which opens locates the defect.

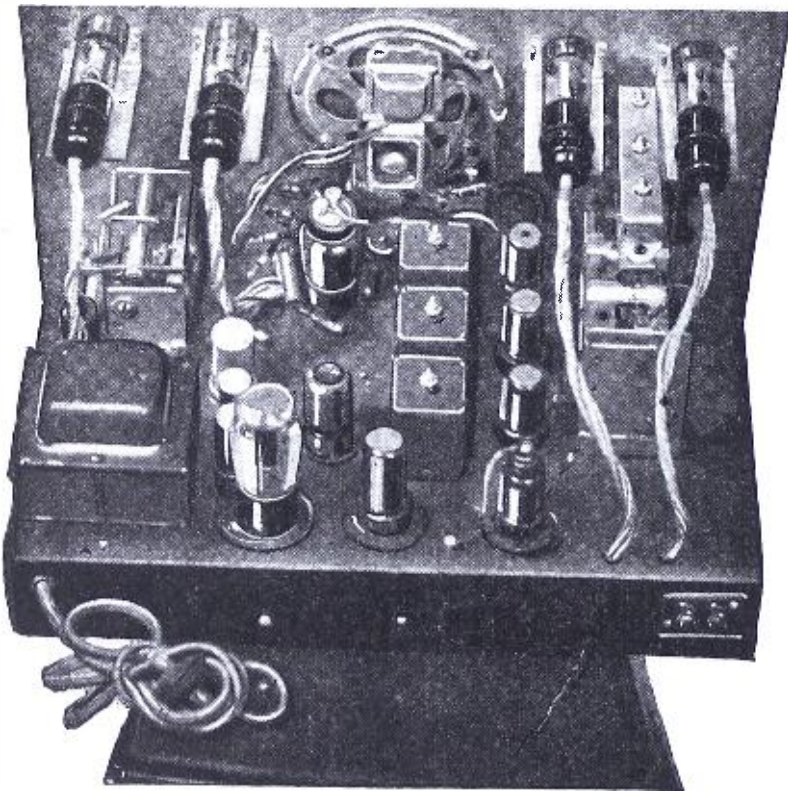

A rear view of the sensitive signal tracer. Note trimmer condenser bank and switch mounted on top of the variable condenser gang.

Possibly the constructor should print the names of every one of the various controls, jacks and indicators on his panel. The designer of an instrument feels so familiar with it—even before it is built—that he seldom feels the need for most of these indications, but a person constructing it from the diagram would doubtless save time if he could distinguish between all controls and switch positions at a glance.

Let me suggest that for tracing intermittents a broadcast signal be used. I find they show up much quicker on a variable modulated signal of broadcast strength than on a steady modulated signal from a signal generator.

A study of the schematic will show how the tracer may be used for different purposes. A full explanation of the manner of employing it would take another article and is unnecessary. There is no difference in the operation of

While this instrument is a bit more complicated to build and operate than many simpler ones described, I find that the difference in performance more than makes up for any extra trouble in building and familiarizing oneself with it.

Note: The resistor and condenser values in the audio input circuit (Sw 3) were inadvertently omitted from the schematic. The condenser is .01 mf (value not critical). The resistor in series with the bias cell is 50,000 ohms, and the resistors shunting the volume control are 2,000, 20,000 and 200,000 ohms respectively. These, in conjunction with the variable volume control, step down the volume to controllable values, no matter how strong the original signal may be.

(Sw 1) the r.f. level control, the output switch (Sw 4) the audio volume control, the audio input switch (Sw 3) the oscillator attenuator and the oscillator wave-change switch (Sw 2). The jacks used with some of these switches are placed as close to them as possible, to avoid long leads.

Functions of all switches, ray-tubes, dials and input and output jacks are given in the combination photo-sketch on the preceding page. The more important points may be marked directly on the panel face, as was done in the case of this instrument. For example, all the ranges of the VTVM were printed on the panel. The antenna position of

manner of employing it would take another article and is unnecessary. There is no difference in the operation of

### CORNER REFLECTORS INCREASE RADAR "VISIBILITY"

**C**ORNER REFLECTORS, small sheets of metal weighing slightly over a pound, enable small life-rafts to be detected as easily as a fair-sized metal craft, the Army Air Technical Service Command announced last month. Radar waves from searching ships or planes are reflected back from these reflectors, and result in a much stronger signal being received at the radar apparatus.

Corner reflectors have been used with u.h.f. receiving and transmitting antennas. (The robot tanks pictured on *Radio-Craft's* last September cover are equipped with small dipoles and corner reflectors.) Those used on life-rafts are made of a wire mesh which is lighter than metal plates, and equally good.

Transmitting no signal, they did not advertise their presence to Japanese listeners.



# RADIO DATA SHEET 333

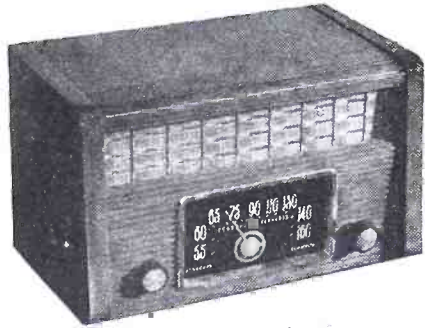

MODELS 103 and 105

## GENERAL ELECTRIC MODELS 100, 101, 103 and 105

### ELECTRICAL CIRCUIT ALIGNMENT

#### ALIGNMENT FREQUENCIES

R.f. .... 1500 kilocycles  
I.f. .... 455 kilocycles

#### EQUIPMENT REQUIRED

1. Test oscillator with audio tone modulation.
2. A.c. output meter, 1 1/2 volts full scale.
3. 0.05 mf paper capacitor.
4. 50 mmf mica capacitor.
5. Insulated screwdriver.

#### PROCEDURE—GENERAL

1. Turn dial scale pointer as far counter-clockwise as possible. The pointer should coincide with the first marking at the left of the scale. If it doesn't, remove chassis and slip pointer on shaft until

the pointer is under reference mark when chassis is bolted in place.

2. For i.f. and r.f. alignments, the output meter is connected across the loudspeaker voice coil terminals.

3. Keep radio volume control at maximum and attenuate test oscillator signal output so that the output meter reading never exceeds 1/4 volts.

4. The chassis must be removed from the cabinet during i.f. alignment. For r.f. alignment bolt the chassis in the cabinet securely, the r.f. and osc. trimmers are then available through the hole in the Beam-a-scope assembly when the back cover is removed.

5. Connect the capacitor as listed in column 2, between the output "High Side" of test oscillator and the point of input specified.

#### ELECTRICAL RATING (INPUT)

Voltage..... 105-125 volts a.c. or d.c.  
Frequency on a.c..... 25 to 60 cycles  
Wattage..... 40 watts

#### OPERATING FREQUENCIES

Broadcast Band.... 540-1600 kilocycles  
I.f. Amplifier..... 455 kilocycles

#### POWER OUTPUT (117 VOLTS LINE)

Undistorted ..... 1.25 watts  
Maximum ..... 2.0 watts

#### LOUDSPEAKER

Type ..... Alnico PM  
Outside Cone Diameter ..... 5/4 in.  
Voice Coil Impedance (400 cycles)  
3.5 ohms

#### TUBE COMPLEMENT

Oscillator-Converter ..... 12SA7  
I.f. Amplifier ..... 12SG7  
Detector-Audio ..... 12SQ7  
Power Output ..... 50L6GT  
Rectifier ..... 35Z5GT/G  
Pilot Lamp .... G-E, C7, 115-volt, 10-watt, clear candelabra screw base

#### ALIGNMENT CHART

Step	Connect test oscillator to	Test osc. setting	Pointer setting on radio	Adjustment for maximum output
1	12SG7 grid in series with 0.05 mf cap.	455 kc	1,500 kc	2nd i.f. Trans. Trimmers
2	12SA7 grid in series with 0.05 mf cap.	455 kc	1,500 kc	1st and 2nd i.f. Trans. Trimmers
3	Ant. Post in series with 50 mmf.	1,500 kc	1,500 kc	C3 (Osc.)
4	Ant. Post in series with 50 mmf.	1,500 kc	1,500 kc	C2 (r.f.)

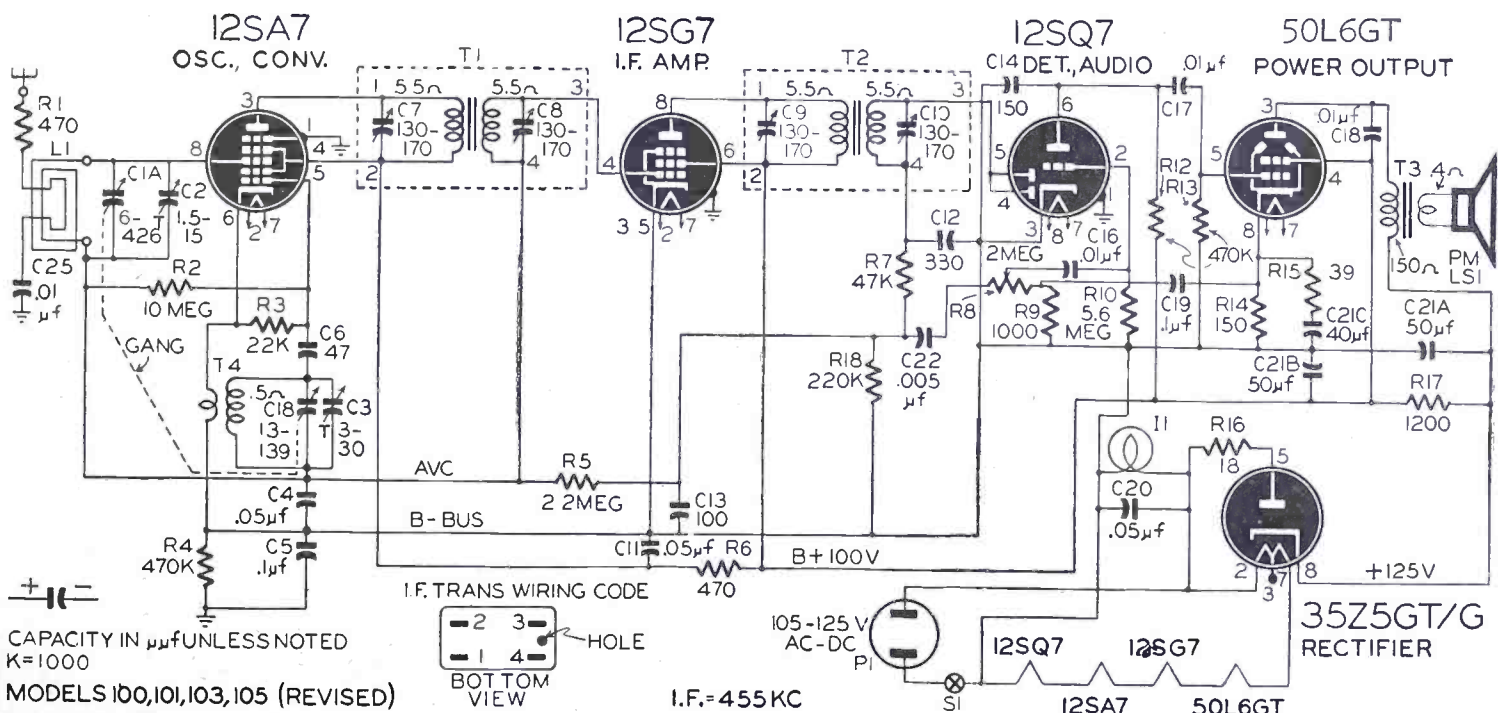



# LIMITING CIRCUITS

## Are Important in Radar, FM and all Pulsing Circuits

Amplitude of waves is of great importance in radar, television and electronics circuits. Control of wave ampli-

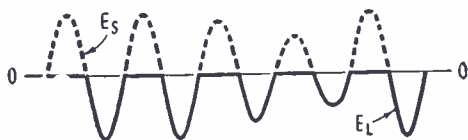
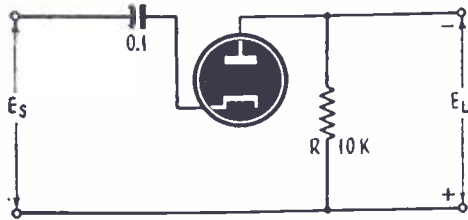

Fig. 1—Positive limiting with series diode.

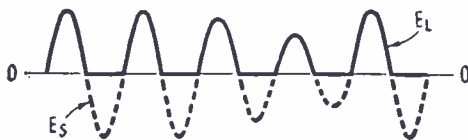
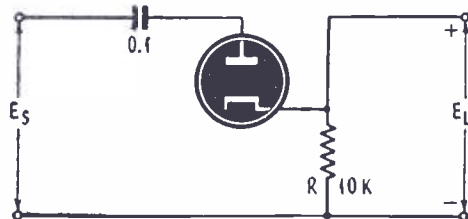

Fig. 2—Similar to above, negative limiting.

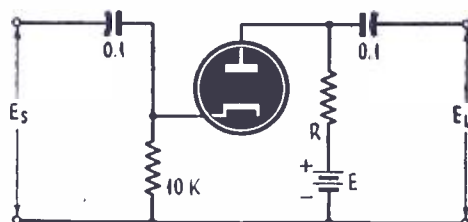

Fig. 3—Series positive limiting above ground.

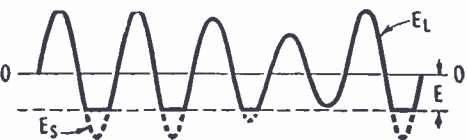
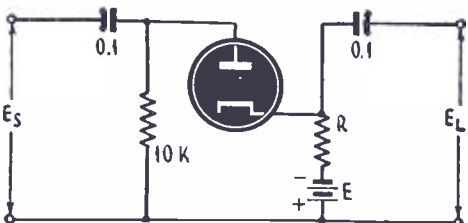

Fig. 4—Series negative limiting below ground.

tude is the function of limiters, sometimes known as clippers.

A limiter removes one extremity or the other, or both extremities, of any form of input wave. In some applications the signal level may be reduced by a limiter, so the output never exceeds a certain datum. Or, only peaks above a certain reference voltage may be allowed to pass the limiter stage.

Limiting action can be accomplished by *Varistors*, or similar devices whose resistance decreases with rising voltage. Selenium and copper-oxide rectifiers also provide some limiting effects. But such devices are difficult to control, lack precise definition, and are none too dependable for exacting work in electronics.

Most effective means of precision limiting is by vacuum tubes. Diodes, triodes, and even pentodes are used for such amplitude control—connected in a variety of circuits, depending upon the type of control action and discrimination required.

For instance, a limiter may function as a protective device: limiting all amplitudes to 50 volts peak—since higher voltages might damage some later stage. Or, a limiter may be required to pass only those parts of an input pulse that exceed 30 volts—thus creating impulses above a certain reference level. A limiter can convert an input sine wave into a square or rectangular wave. A peaked wave can be converted into a step-front pulse by removing positive or negative extremities.

Thus, a limiter may be used as a wave-shaping circuit, in addition to its amplitude discrimination duties.

Limiting circuits are classified according to five types: (1) Series diode limiters, (2) Parallel diode limiters, (3) Double diode limiters, (4) Triodes, tetrodes, and pentodes with grid limiting, and (5) Overdriven amplifiers. Inclusion of overdriven amplifiers in the class

of limiting circuits is entirely accurate, even though such devices are occasionally referred to as square-wave generators.

### THE DIODE PRINCIPLE

Conduction takes place in a diode vacuum tube only when the plate is positive with respect to the cathode (or the cathode is negative with respect to the plate). Under such conditions, electrons pass from the cathode only in the direction of the plate.

This unilateral characteristic of the ordinary diode makes it ideal for limiting purposes.

If the cathode is grounded, the plate must be positive with respect to ground for conduction to take place. If a fixed positive voltage is applied to the cathode, the diode will not pass current until the plate has risen above an equal positive voltage. In much the same manner, if the cathode is biased below ground potential, the diode will conduct only when the plate is above the negative value of the cathode voltage.

Current begins to flow in the diode circuit when the plate is first made positive with respect to the cathode. As the plate becomes more positive, the flow of current increases rapidly and the internal resistance of the diode diminishes to a few hundred ohms.

Use of the diode as a limiter permits control of the threshold of action over wide limits of voltage.

The output wave will be a direct function of the input signal for any type of diode limiter, and, neglecting minor circuit losses, a unity transfer of energy can be expected.

The same wave-train of varying amplitude is used to illustrate the function of all of the following limiter circuits. But the limiter action is independent of the form or shape of the input wave.

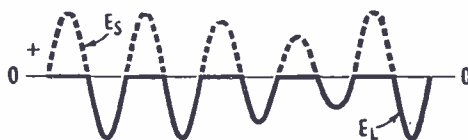
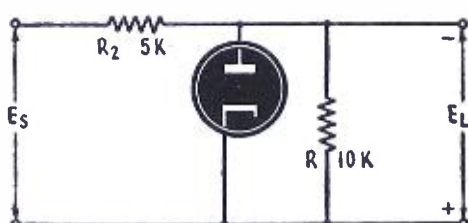

Fig. 5—Positive limiter with parallel diode.

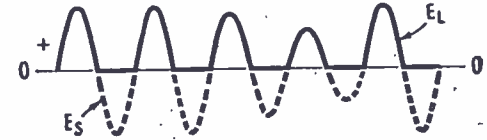
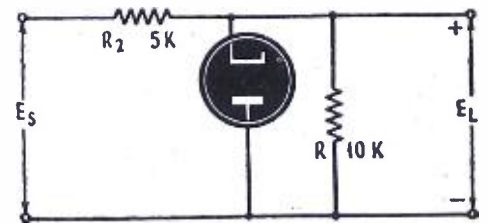

Fig. 6—Negative limiting version of Fig. 5.



Simplest diode arrangement is a series limiter circuit in which the tube functions much as a rectifier or polarity switch.

When the input signal  $E_s$  is applied to the series diode circuit (Fig. 1), the tube cannot conduct during positive alternations, because the cathode is positive with respect to the plate. In addition, the resistor  $R$  is large enough to prevent any small current flow. Therefore, during positive portions of the input signal there is no output voltage.

During negative alternations, however, the diode conducts normally. Polarity of the output voltage  $E_L$  developed across the resistor  $R$  is the same as the applied voltage of the signal.

### SERIES DIODE LIMITERS

This circuit (Fig. 1) provides what is known as positive limiting, since a positive portion—in this case, *all of it*—is limited or removed from the input.

By merely reversing the diode connections, the circuit (Fig. 2) can be used to limit negative portions of the signal voltage. In this arrangement, the tube conducts only during positive alternations. There is no output voltage  $E_L$  during negative cycles of the signal.

These two simple series circuits (Figs. 1 and 2) limit the input wave to the base line or zero axis, in true rectifying manner.

Often in radar and electronics work it is necessary to provide positive or negative limiting at some fixed value above or below ground.

When a fixed positive voltage is applied to the plate, a diode conducts at all times except when the positive swing of the input signal to the cathode exceeds this voltage.

Such a series diode limiter (Fig. 3) provides positive limiting above ground. And the positive voltage level (above ground) depends upon the amount of fixed positive voltage  $E$ .

When the input signal  $E_s$  is applied to this circuit, all voltages having a positive value greater than the bias voltage  $E$  will stop the diode from conducting. All positive peaks will be "clipped" or limited.

Since the amount of bias determines the amount of positive-peak limiting, a *negative* bias voltage  $E$  would result in *extreme* limiting of the positive peaks. This level of limiting would be *below* ground.

By reversing the diode and bias connections, as shown in figure 4, the nega-

tive peaks of the input signal can be limited below ground. All portions of the input signal  $E_s$  having a negative value greater than the bias voltage  $E$  will stop conductance of the diode.

Since the amount of limiting is determined by the bias voltage  $E$ , a *positive* bias voltage would result in *extreme* limiting of the negative peaks, or a limiting action *above* ground.

### PARALLEL DIODE LIMITERS

If a limiting diode is connected in parallel with the circuit load, during periods of tube conductance unwanted energy will be short-circuited and effectively dissipated without appearing in the output.

Such an arrangement (Fig. 5) provides positive limiting action.

Since the cathode is at ground potential, all input voltages above ground cause the diode to conduct. When the input signal  $E_s$  is applied, positive alternations thus cause a current flow through the tube and through the series resistor  $R_2$ . As this resistor is large compared to the internal resistance of the tube, positive portions of the input wave are dissipated and do not appear across the load resistor  $R$ .

Negative alternations of the input  $E_s$  are unaffected by the parallel diode, and are reproduced in the output without distortion.

By merely reversing the connections of the diode, negative limiting can be provided (Fig. 6).

Action of this circuit is similar to that just described. But *negative* portions of the input signal are dissipated in the series resistor  $R_2$ . And positive portions are unaffected by the parallel diode.

The two circuits (Figs. 5 and 6) limit the input wave to the zero axis, or ground potential. Since it is often desirable to limit the signal voltage to some established positive or negative reference level, a fixed voltage can be introduced to one or the other of the diode electrodes for this purpose.

In the parallel limiter circuit (Fig. 7), the cathode of the tube is more positive than the plate by the amount of the fixed voltage  $E$ . Whenever positive cycles of the input exceed the voltage  $E$ , the tube conducts and the voltage is dissipated in the resistor  $R_2$ . However, when the input does not exceed the fixed bias voltage, the diode will not conduct. And the output will be an exact replica of the input signal. This circuit pro-

vides positive limiting at a given voltage above ground.

Positive limiting *below* ground can be achieved by merely reversing the polarity of the bias voltage  $E$ . When the input  $E_s$  is then applied to the parallel circuit (Fig. 8), the diode conducts at all times except when negative alternations exceed the fixed voltage  $E$ . Thus most of the input signal is dissipated in the series resistor  $R_2$ . Output consists of a series of negative-going impulses.

Negative limiting below ground is accomplished by the circuit shown in Fig. 9. The bias voltage  $E$  prevents the diode

(Continued on page 426)

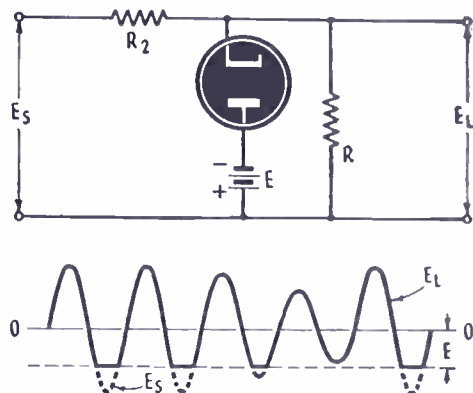

Fig. 9—Below-ground parallel-diode limiter.

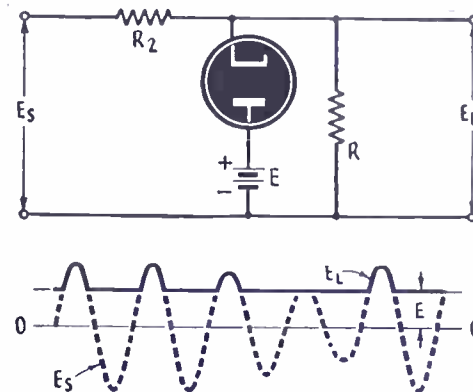

Fig. 10—Above-ground parallel-diode limiter.

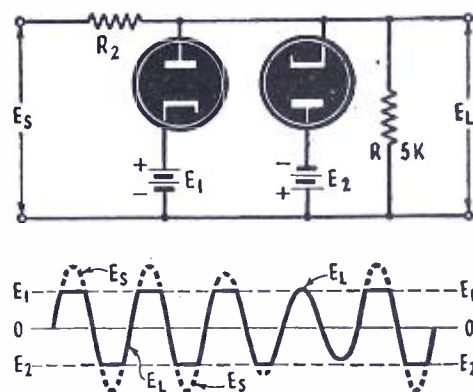
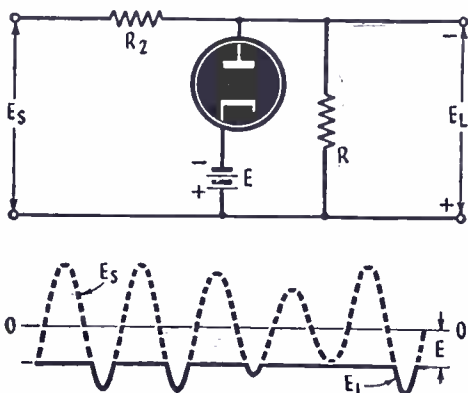
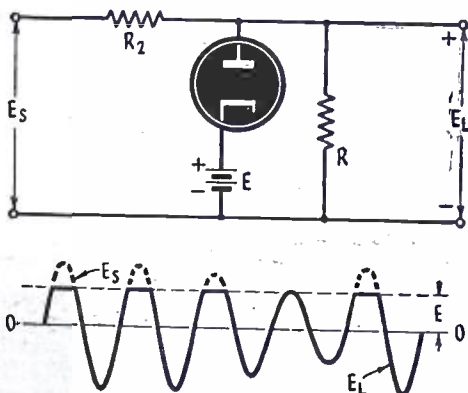

Fig. 11—Both positive and negative limiting can be accomplished with a double-diode tube.



Figs. 7 and 8—Positive limiting above and below ground with a parallel diode circuit.

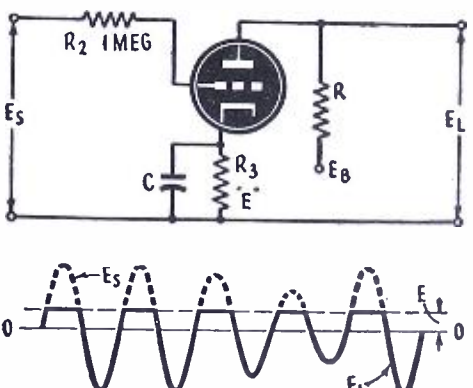

Fig. 12—Triode positive grid-limiter circuit.



# THE CRYSTAL FILTER

## A Clear Explanation of How the I. F. Crystal Filter Works

**W**ITH the advent of postwar radio activity, it becomes increasingly important to work out methods of combatting interference. The once broad region between 2,000 and 25,000 kilocycles has become a highly restricted area in which every possible use must be made of available frequencies. Moreover, as commercial circuits become more important in the general communications picture, it becomes necessary not only to receive a signal but to do so continuously and reliably in spite of the increasing interference.

Receiver selectivity is easily the greatest weapon against interference. A se-

lective circuit not only discriminates against unwanted signals, but also helps out against static and noise by reducing the amount of such noise that can get through with the signal.

A crystal filter, as used in a high-quality communications receiver, provides the most highly selective circuit readily available. Proper use of a crystal filter can work wonders with a weak signal in a cluttered band. As an example, it is easy with a crystal filter to separate the two components of a frequency-shift keyed signal, only about 800 cycles apart, and listen to either at will. With some of the better receivers, it is possible to listen to one of the

Robert W. Ehrlich was born September 22, 1922, at Newark, N. J. He studied electrical engineering at the University of Michigan and taught basic radio there one year as an undergraduate. Upon gradua-



tion became a member of the U.S. Army Signal Corps. His chief work has been to prepare technical manuals, training films and other training aids concerning radio subjects. Is a contributor to several radio and electronic periodicals. Special interests: High-fidelity sound, television and FM.

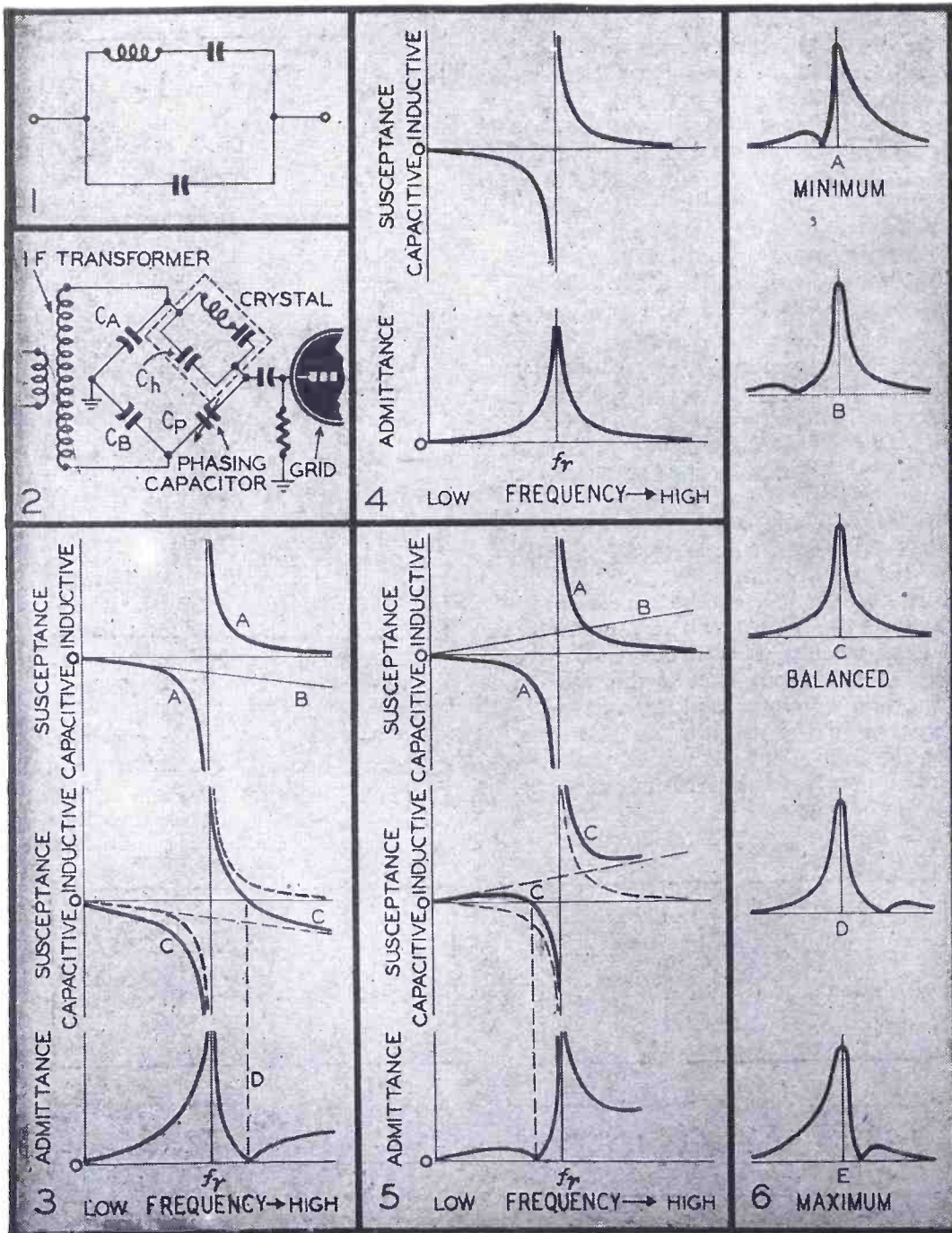

440-cycle sidebands of station WWV and completely eliminate the carrier and the other sidebands.

While these stunts have little or no practical value, they serve to show what a crystal filter can do if the basic principles of its operation are known and considered. On the other hand, the high selectivity of a crystal makes it worse than useless if operation is attempted in a haphazard manner. The theoretical and practical considerations behind crystal operation are easy to understand, and they should become a part of the knowledge of every operator.

To start with, scientists have shown that a crystal by itself is electrically equivalent to a series resonant circuit of extremely high Q. This value of Q may approach 3000. Since the crystal is used in a holder, there will also be

1—Equivalent circuit of crystal and holder. 2—How crystal is hooked up in the receiver. 3—Susceptance of shunted resonant circuit. 4—Curve for crystal alone. 5—Curve when  $C_p$  is increased. 6—Receiver selectivity curves.



some capacitance across the crystal. The equivalent circuit of the crystal in its holder is then as shown in Fig. 1.

### CRYSTAL FILTER CIRCUIT

Fig. 2 shows the basic hook-up of a crystal in the i.f. section of a superheterodyne receiver. Capacitors  $C_A$  and  $C_B$  are usually equal, and in series they resonate with the i.f. transformer secondary at the intermediate frequency.  $C_P$  is the phasing capacitor, and, as will be shown, controls the selectivity characteristics of the circuit. Suppose, first, that the phasing capacitor has zero capacitance, i.e., is not there at all. Then the voltage at the grid will be one-half the voltage appearing across the i.f. transformer secondary, modified by the *admittance* (opposite of impedance) vs. frequency response of the crystal unit. Since the crystal selectivity is so much sharper than any of the i.f. transformers, it is safe to say that over a limited frequency range, a curve of response vs. frequency taken at the grid will be identical to a curve of admittance vs. frequency for the crystal and holder alone. (i.e., series resonant circuit shunted by a capacitance  $C_B$ ).

Suppose now that the phasing capacitance ( $C_P$ ) is equal to the crystal holder capacitance ( $C_B$ ), and that  $C_A$  and  $C_B$  are equal. As far as these capacitors are concerned, this is now a balanced circuit, similar to a Wheatstone Bridge. No voltage will appear at the grid due to the action of the capacitors. The only voltage will be what can pass through the series-resonant portion of the crystal. The selectivity curve at the grid will then be the very sharp curve of the crystal alone. Its peak amplitude will be once again one-half the i.f. transformer secondary voltage.

Third, suppose the phasing capacitor ( $C_P$ ) is larger than the holder capacitance. Considering first the capacitors in the circuit, we find more voltage at the grid due to  $C_P$  than there is due to  $C_B$ . In addition, the voltage due to  $C_P$  is  $180^\circ$  out of phase with that due to  $C_B$ . Effectively, there is now a *negative capacitance* across the crystal; and the selectivity curve is the same as the admittance vs. frequency curve of a series resonant circuit shunted by a negative capacitance.

### SELECTIVITY CHARACTERISTICS

Now we have three conditions for which it would be desirable to find the selectivity curve. Turning back to the first case, a curve is needed of admittance vs. frequency for a sharp series resonant circuit shunted by capacitance. To get the curve, we first draw the curve of *susceptance* (inverse of reactance) vs. frequency for the series circuit alone. (See Fig. 3a.) To this curve is added the susceptance of the capacitor (Fig. 3b). The composite susceptance curve (Fig. 3c) is drawn in absolute values in figure 3d to show the overall admittance of the crystal circuit. Note that there is a frequency of peak response, corresponding to the series resonant frequency ( $f_R$ ) of the crystal, and, in

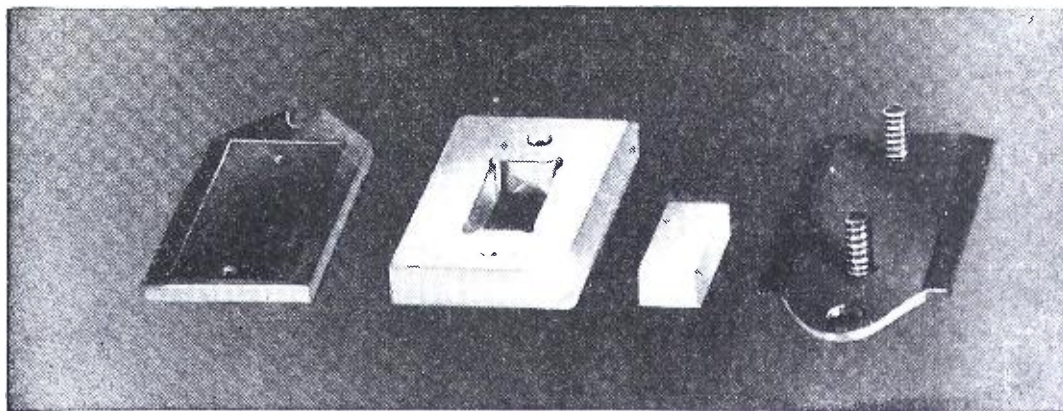

Low-frequency crystal and holder. The metal end-plates act as electrical contacts as well as hold the thick (approximately 455-kc) quartz crystal in the hollow ceramic block.

addition, a frequency of strong rejection a little higher than the peak response frequency. The difference between these two frequencies is usually less than 100 cycles.

The second case mentioned above, that of the series-resonant crystal alone, is drawn in Fig. 4. Note that there is no rejection frequency, and that the selec-

tivity is sharper than that shown in Fig. 3.

The third case, where a negative capacitance appears across the crystal, is drawn in Fig. 5. These curves are derived in the same manner as those of Fig. 3. Note that the rejection frequency is now on the *low* (Continued on page 442)

### LIGHTNING EXPLODES RADIO

**S**HATTERING, exploding, and tearing in its mad search for the opposite charge in mother earth, lightning played havoc recently at the home of Mr. and Mrs. E. D. Robinson in Thompson Falls, Montana.

The radio pictured was midway in the path of the charge which came in on the antenna wire. To have a radio destroyed by lightning is not entirely unknown, but in this case the receiver was absolutely unharmed electrically. In fact, a few days before the storm, one of the radio tubes had burned out, but after the bolt struck, all tubes tested good and the radio was in working order except for the missing paper loud-speaker cone which had been neatly torn from the frame.

Pieces of the exploding radio cabinet were thrown forcibly against a wall twenty-four feet away, while Mrs. Robinson, who was sitting a few feet from the set, was unharmed except for the shock of having a radio explode like a bomb before her.

Striking first a tall pine tree, the lightning tore a long strip of bark from it, then coursed along the radio antenna wire attached to the tree, shattering two large window panes and the sill.

Finally reaching the radio and exploding it, the electricity splintered the radio table leg. Several pieces of the hardwood leg can be seen in the photograph.

Next the charge leaped to a baseboard, ripped it from the wall and proceeded along the wall and through to the adjoining room.

In a last diabolical effort the bolt passed through an outside wall, tearing off several shingles just before reaching earth.

After leaving the radio, a secondary path taken by the lightning tore the corner from a mattress. Throughout the whole freakish course no trace could be found of burning or scorching.

W. H. BLANKMEYER,

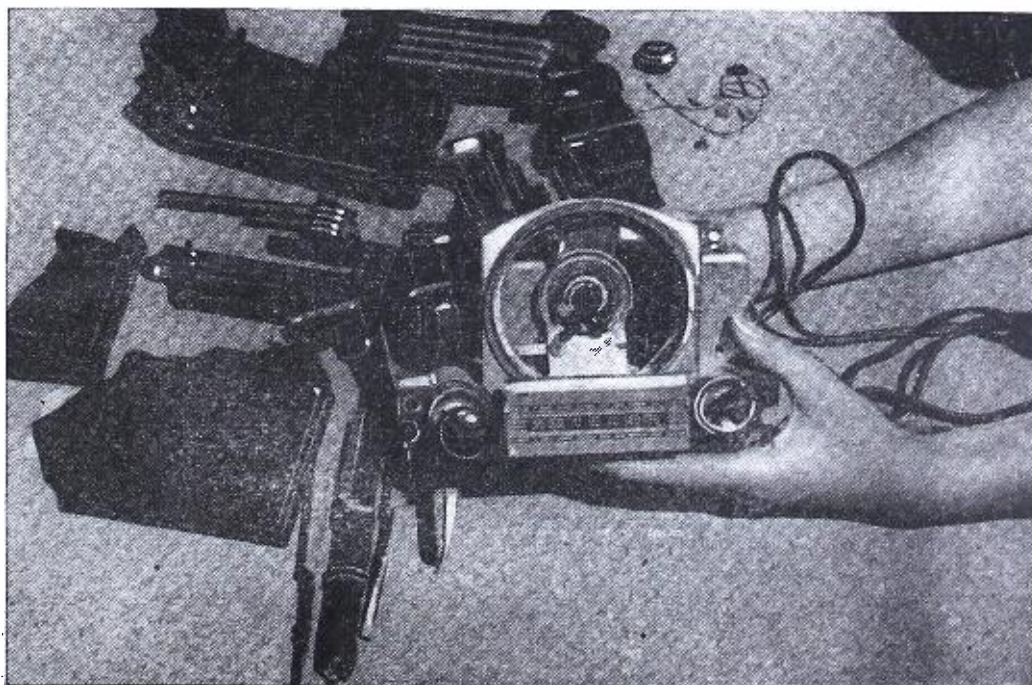



# DECIBEL PROBLEMS

## Part II—Calculations From Voltage and Current Ratings

**W**E HAVE found that the decibel expresses changes in power by various ratios. If we adopt a specific value of power as a reference level (or *zero preference*) we can express any power in decibels as a difference or change above or below this arbitrary reference value.

For electrical power the standard reference level is .006 watts or 6.0 milliwatts. This zero reference value in the electrical power level scale was established years ago as follows: the familiar telephone transmitter and sub-set were connected through a mile of standard cable (loss about 1 db) to a vacuum-tube volume indicator with input loaded to 500 ohms. The average deflection resulting with an average person speaking was marked zero level. With a 1000-cycle sine-wave tone applied to the input and the v.i. (volume-indicating) meter adjusted for deflection to zero level, it was found that .006 watts was taken by the load. This reference power was used universally by the Bell Telephone system and broadcast radio stations. The db meter, however, being essentially a peak-reading or sine-wave instrument, was not entirely suitable to the complex nature of sound waveforms encountered in broadcasting. Another system was therefore developed.

A new unit called v.u. (volume unit) was adopted several years ago, using a reference level of one milliwatt (.001 watt) across a load impedance of 600 ohms. The zero reference level in v.u. = 0.6 volts (RMS) at 1000 cycles per second. This new system indicates the average or RMS value of sound energy and thus is more applicable to broadcast work. The difference between the two reference levels is 7.9 db. An amplifier rated at 40 db above .001 watt is only 32.1 db above .006 watt. But now back to our discussion of the decibel. The levels of sound power in electrical form are expressed as changes above or below this .006 watt reference and may be determined by the formula:

$$\text{Power Level (db)} = 10 \log W/.006.$$

Example: The maximum output of an amplifier is 60 watts. This is a power level of  $10 \log 60/.006 = 10 \log 10,000 = 10 \times 4 = 40$  db. The power levels for various values of power may be computed either by slide rule or a table of logarithms.

### VOLTAGE AND CURRENT RATIOS

Strictly speaking, the decibel deals with power ratios only, but power is given in terms of current or voltage by:  $W = I^2R$ , or  $W = E^2/R$ . Thus power

may be calculated from the current or voltage if the resistance is known. However, for a change in voltage *across a given resistance*, the corresponding power changes may be determined without regard to the value of resistance. This change is calculated from:  $W_2/W_1 = E_2^2/E_1^2$ . In other words,

$$\frac{\text{Final Power}}{\text{Initial Power}} = \frac{\text{Square of Final Voltage}}{\text{Square of Initial Voltage}}$$

From this relationship we see that a power ratio of 3 represents a voltage ratio of 9, a power ratio of 100 ( $10^2$ ) equals a voltage ratio of 10,000 ( $10^4$ ), etc.

We found previously that a power ratio of 10,000 is 40 db., and of 100 is 20 db. If we calculated decibels from the voltage ratio in the same way as for power ratio, we would arrive at 20 db when the result should be 40 db. This gives us the rule: To obtain db from a voltage ratio, proceed the same as for a power ratio and multiply the result by 2. The formula for db for a power ratio was given above as  $10 \log$  of the power ratio. The formula for a voltage ratio is therefore,  $2 \times 10 \log$  of the power ratio, or, db voltage ratio =  $20 \log E_2/E_1$ . The factor 2 is introduced due to the fact that power depends on the *square* of the voltage. Power also depends on the square of the current, so the formula for db from a current ratio is db current ratio =  $20 \log I_2/I_1$ . (Multiplying a log by 2 is equivalent to squaring the number for which it stands.)

### VOLTAGE LEVEL

Returning to the expression of power in terms of voltage and resistance,  $W = E^2/R$ , it is obvious that we can find a value of voltage corresponding to .006 watt (the power level reference value) if we decide what value of resistance to use. Selecting 500 ohms as the most convenient value of resistance, since so many amplifiers are designed to work into 500 ohms, this voltage reference value is found as follows:

$$E^2/500 = .006; E^2 = .006 \times 500 = 3; E = \sqrt{3} = 1.73 \text{ volts.}$$

For the assumed value of resistance (500 ohms) we see that the reference value of power expressed in volts is 1.73. It is often desirable to use this voltage as a zero reference for a scale of *voltage levels* expressed in db. By taking the ratio of any voltage to the reference voltage (1.73), we can express the voltage in decibels voltage level, using the

(Continued on page 429)

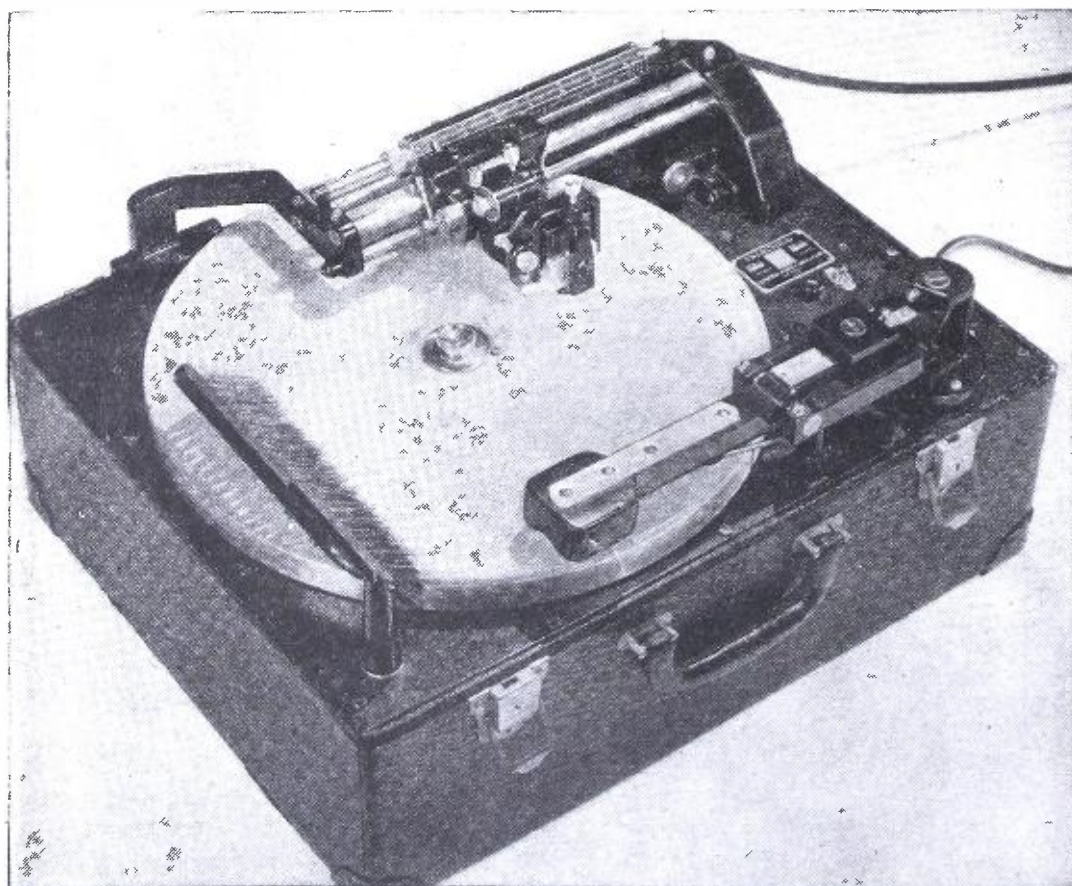
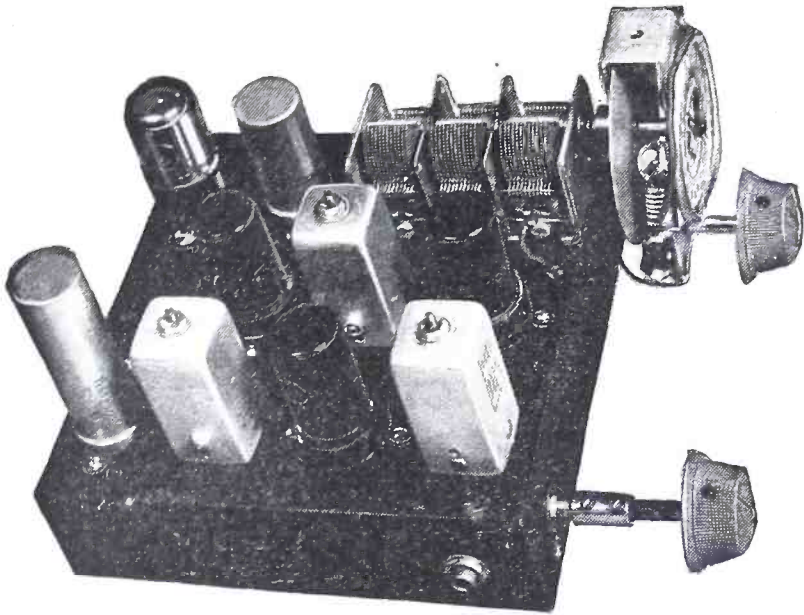

Photo courtesy Fairchild Camera and Instrument Co.

Development of recording apparatus like this requires knowledge and use of sound ratings.





# HI-FI TRF TUNER

**T**HIS TRF tuner was designed for those who wish to get the most that our present AM broadcasting system has to offer. There are some AM stations on the air which justify the building of a high quality tuner.

With the above thoughts in mind, and the fact that a high quality amplifier speaker system was on hand, this tuner was designed. Several features are incorporated that prove their worth. Point-to-point wiring is used, therefore, by-pass condensers and resistor circuit elements are where they will be most effective. Point-to-point wiring, in general use now, is mentioned because of advantageous circuit features that the old style condenser and resistor board assembly did not have. The condenser or resistor circuit element is connected directly to the tube socket or other circuit element where it will be the most effective, and not on a resistor or condenser board with long leads or cables running to it.

As is common with this type of tuner, hum is eliminated by following a few well-known circuit features. Contrary to popular opinion, the design and construction of a TRF tuner, the functions properly, is more difficult than the common superheterodyne type of tuner.

One of the circuit features is that the filament circuit must be grounded in the tuner only and preferably by center-tapped filament resistors. Each r.f. tube cathode is bypassed to ground with a section of a triple section, 40  $\mu$ f per section 25-volt electrolytic condenser.

Another circuit feature that overcomes tunable hum (common in this type of tuner) is the use of the FP (fabricated plate) type of electrolytic condenser, a dual 20-450 volt type FP as manufactured by Magnavox and Mallory. There are many condensers of other manufacture that are similar in appearance and form factor, however, they are nothing but the common etched foil type of electrolytic condenser. It is advisable to use only either make as previously mentioned as this type of electrolytic condenser has the lowest r.f. impedance. If the maximum advantage is to be obtained, it should be mounted near the source of r.f., and not in the power supply. It should also be pointed out, that while this condenser should be mounted close to the r.f. source, it should not be too near a tube or other source of heat, as heat will materially shorten its life, also raise its r.f. impedance after a while.

Full action a.v.c. is incorporated and the time constant is sufficiently long

not to cause any trouble from the so-called "bass frequency modulation."

It was also found by trial that the r.f. gain control was most satisfactory in the r.f. tube's screen circuit rather than in the cathode as is normally used. With this arrangement, good super-control tube characteristics were had.

The coils (A-320-A and A-320-RF), are made by the J. W. Miller Co. One improvement can be made on the type specified for TRF service. The two-turn "gimmie"—a short length of wire that is used to increase the gain at the high frequency end—should be removed from each coil. This two-turn loop connects to the plate lug and is wound around the grid end of the tuned coil. On the antenna coil it is connected from the antenna lug and wound as on the other coils. This two-turn "gimmie" is actually an inexpensive low-capacity fixed condenser. It is used by almost every coil manufacturer and if similar coils of any other manufacturer are used should be removed, as its removal increases the receiver's overall selectivity.

Alignment should be done with minimum signal and use should be made of the slotted end plates on each gang section of the three gang condenser. The

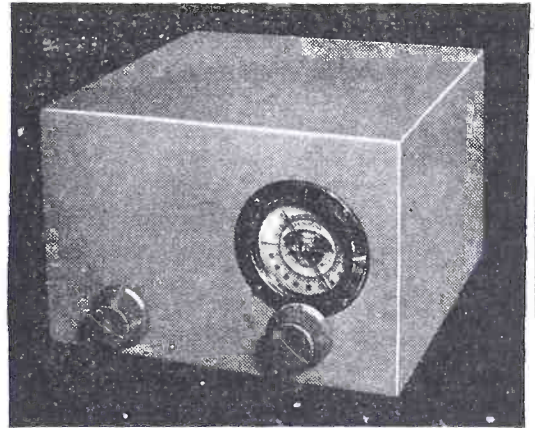

The high-fidelity tuner in its metal cabinet.

high-frequency end is adjusted by the gang trimmers and is done with a 1380 kc signal with the gang 20 divisions meshed, zero to 100 being complete condenser rotation. The low-frequency end is adjusted by variable iron cores of the coils. This is done at 580 kc after the

(Continued on page 415)

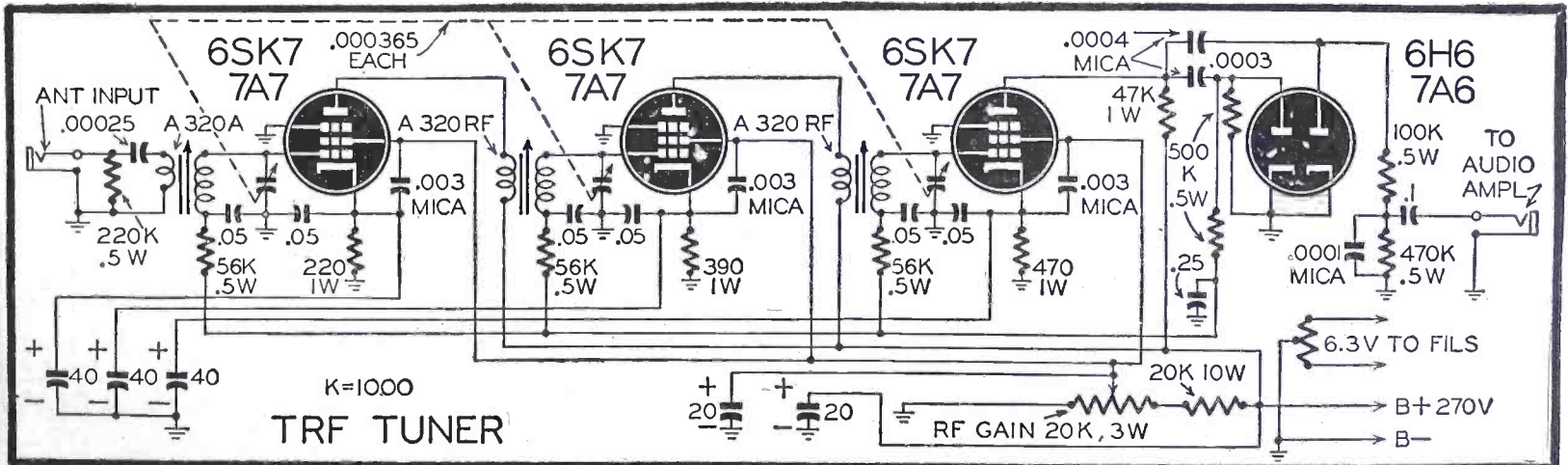



# WORLD-WIDE STATION LIST

**W**ITH spring coming and the days getting longer, we can look forward to changing conditions on the short wave bands. The high frequency bands should be staying open later in the evening with the advent of later sunsets, and some very good results should be forthcoming from the 16 to 19 meter bands. Also, the 10 meter ham band should improve over what it has been for the past two or three months. Activity down here has been very weak, but we hope that it will soon pick up. Short skip has been present most of the time, with once in a while the W6's and the Hawaiians breaking through. It sure will be nice when some of the other ham bands are turned back to us. Ten meters is all right to play around with, but not for down-to-earth dependability.

The International Service of the Canadian Broadcasting Company now has four short wave stations operating as follows: CKNC on 17.82 megacycles, at 7 a.m. to 2 p.m.; CKCX on 15.19 megacycles, at 7 a.m. to 3 p.m.; CHOL on 11.72 megacycles at 2:15 to 7 p.m.; and CKLO on 9.63 megacycles at 3:15 to 7 p.m. All of these are heard in both French and English in every part of the U. S., and the power used is 50,000 watts each.

Several months ago it was reported that the station at St. Kitts, British West Indies, had closed down. A letter received the other day from the former engineer and manager, R. D. Stewart, stated that he and C. J. Stewart were planning a new amateur transmitter for operation from Barbados, B.W.I. This outfit will use 120 watts to the final, and will be phone and c.w. operated. Other hams there are also preparing to return to the air as soon as licenses are granted, and it is expected that there will be about ten stations transmitting from that island on the amateur bands. Amateurs in Barbados are hopeful of early permits for transmissions, but to date nothing definite has been heard.

At present it is not possible for us to give the power of many of the short wave stations, but we will give it in this column whenever the information is available to us. If our readers desire it, we could mark the most often and best heard stations. Let us hear what you think of this idea. Several have requested the power, but to get this information is a long job, as several short-wave stations do not specify their power.

OLR2A in Prague, Czechoslovakia, is heard at 2 to 5:15 p.m. on 6.010; with OLR3A on 9.550 megacycles at 9:30  
(Continued on page 431)

STATION Call	Frequency	PM										AM								
		9	10	11	12	1	2	3	4	5	1	2	3	4	5					
YV1RT	3.370	X	X	X	X	X														
YV5RY	3.380	X	X	X	X	X														
YV4RK	3.390	X	X	X	X	X														
YV5RW	3.400	X	X	X	X	X														
YV4RQ	3.480	X	X																	
YV3RS	3.490	X	X																	
YV5RX	3.500	X	X	X	X	X														
YV6RC	3.510	X	X																	
YV5RS	3.530	X	X	X	X	X														
HCJB	4.105	X	X	X	X	X														
YV1RV	4.750	X	X																	
YV4RO	4.780	X	X																	
YV1RL	4.810	X	X	X	X	X	X	X												
HJBB	4.815	X	X	X																
HJED	4.825	X	X	X	X	X	X	X												
YV1RZ	4.840	X	X	X																
HJCA	4.855	X	X	X	X															
YV5RM	4.890	X	X	X	X	X														
HJCH	4.895	X	X	X																
YV5RN	4.920	X	X	X	X	X														
HJAP	4.925	X	X	X																
HJQC	4.955	X	X	X	X	X	X	X												
HJAE	4.965	X	X	X	X	X														
HJAG	4.975	X	X	X	X	X	X	X												
YV3RN	4.990	X	X	X	X	X														
OAX1B	5.580	X	X	X	X	X	X	X	X	X										
HRN	5.875	X	X	X	X	X	X	X												
ZRK	5.885								X	X	X	X	X	X						
OAX4Z	5.895	X	X	X	X	X	X	X	X	X										
HP5K	6.005	X	X	X	X	X	X	X												
CJCX	6.010	X	X	X	X	X	X	X	X	X										
HJCX	6.018	X	X	X	X	X	X	X	X	X										
GSA	6.050								X	X	X	X	X	X	X	X	X	X		
GRR	6.070	X	X	X	X	X														
ZYB7	6.095	X	X	X																
GSL	6.110	X	X	X	X	X	X	X	X	X										
HJCD	6.160	X	X	X	X	X	X	X	X											
GRO	6.180														X	X	X	X	X	X
VUD7	6.190	X	X	X																
JLT																			X	X
YV6RD	6.200	X	X																	X
HJCF	6.240	X	X	X	X	X	X	X												
HI1N	6.243	X	X	X	X	X														
HCJB	6.280	X	X	X																
HE12	6.344	X	X	X									X	X	X	X				
TGWB	6.465	X	X	X	X	X	X	X	X	X	X	X	X	X						
HI2T	6.485	X	X	X	X	X														
JVT	6.750																			
GRS	7.065							X	X	X	X	X	X	X	X	X	X	X	X	X
GRM	7.120												X	X	X	X	X	X	X	
GRT	7.150											X								
GRK	7.185	X	X	X	X	X	X													
GWL	7.205	X	X	X	X	X	X	X	X	X										
FGY	7.210														X	X	X	X	X	X
VIQ2	7.215																			
JCKW	7.220						X	X	X	X	X	X	X	X	X	X	X	X	X	X
GSW	7.230		X	X	X	X	X	X	X	X					X	X	X	X	X	X
GSU	7.260	X	X	X	X	X	X	X	X	X										
JVW	7.260	X	X	X	X	X	X	X	X	X										
VUD3	7.290	X	X	X	X	X	X	X	X	X										
USSR*	7.300	X	X	X	X	X	X	X	X											
GRJ	7.320	X	X	X	X	X														
HEK3	7.380	X	X	X																
AFN**	8.580											X	X	X	X	X	X	X	X	X
COCO	8.695	X	X	X	X	X	X	X	X											
COCQ	8.830	X	X	X	X	X	X	X	X	X										
HEF4	9.185	X	X	X																
FZI	9.440											X	X	X	X	X	X	X		
USSR*	9.480											X	X	X	X	X	X	X		
XEWW	9.500	X	X	X	X	X	X	X	X	X	X	X	X	X	X	X	X	X	X	X
GSB	9.510	X	X	X								X	X	X	X	X	X	X	X	X
Paris	9.520																			
USSR*	9.565	X	X	X	X	X	X	X	X	X					X	X	X	X	X	X
GSC	9.580	X	X																	
OTC	9.745	X	X	X	X	X	X	X	X											
GRH	9.825	X	X	X	X	X	X	X	X											
USSR*	9.860	X	X		X	X	X	X	X	X	X	X	X	X	X	X	X	X	X	X
USSR*	10.450											X	X	X	X	X	X	X		
CMCY	11.680	e	v	e	n	i	n	g	s											
PRL8	11.720	X	X																	
VLA4	11.770											X	X	X						
CXA19	11.835	X	X	X																
Burma***	11.860											X	X	X	X	X	X	X	X	X
FXI	11.970											X	X	X	X	X	X	X	X	X
USSR*	12.265	X	X		X	X	X	X	X	X	X	X	X	X	X	X	X	X	X	X
HCJB	12.445	e	v	e	n	i	n	g	s											
KU5Q	15.920	X	X	X	X	X	X	X	X											
FZI	117.525											X	X	X	X	X	X	X	X	X

\*\*\*Rangoon  
\*\* Munich, Germany  
\* Moscow, U.S.S.R. (no call used)

(X's indicate hours stations are on the air.)



# SUPER-REFLEX RADIO

*An Improved Version of the "Startling Superheterodyne"*

**A** FEW YEARS ago, a super-heterodyne radio had to consist of at least seven tubes because multiple tubes had not been developed. Now a truly excellent three-tube super is practicable, and the cost is very low.

This set is similar to the one published in *Radio-Craft* (page 783, September, 1945), but contains many improvements for increased efficiency, and the cost has been further reduced.

Those skilled in the art of building radios need nothing further than the schematic diagram which, so far as practicable, is intended to be self-explanatory. However, for others who aspire to build their own set, here are some fundamentals on how best to go about its construction.

First consider the coils. Assume you are building a broadcast set, 1700 kilocycles (kc) down to 540 kc, and that the intermediate frequency (i.f.) is 456

kc. The network C1, C3 and L1 must be such as will cover this band. The condenser C3 can be of the compression type; its purpose is to correct for length of antenna. Thus, if the antenna is very short, more capacity is required in C3. If the antenna is long, less is required.

The coil, L1, should be iron-core. Any radio-frequency iron-core coil can be altered to serve the purpose by completely removing the primary and about 10 turns of the secondary. Also, a small radio-frequency powdered iron-core choke can be reduced to the proper value. Or you may make your own provided you have the iron core. You should start out with very little capacity in C3 and gradually remove turns from L1 and close up on C3 until the full band is covered by C1.

The coil L2 is the oscillator, consisting of a primary connected to prong 6 of the 6A8 tube, and a secondary connected through the 100  $\mu$ f condenser to prong 5. It is tuned by condenser C2, and C5 (padding condenser), to a frequency 456 kc higher than L1, or from 2156 kc down to 996 kc. Coil L2 can best be a good-quality air core factory job, designed for use in a set with 456 kc intermediate frequency. The capacity of condenser C5 must be that specified by the manufacturer of coil L2, usually 350 to 400 mmf. The correct value is most important as if the padder is not cor-

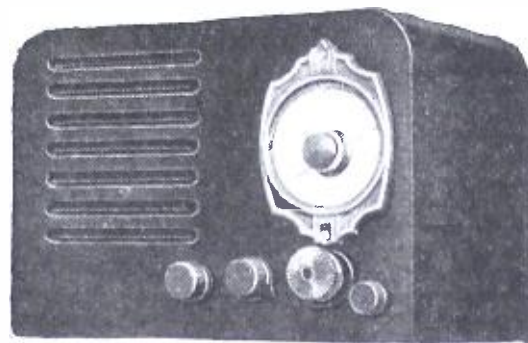

Mr. Connatser's 3-tube radio in its cabinet.

rect, the circuits will not track.

Condensers C1 and C2 are ganged, and can have a maximum capacity ranging from 350 to 370  $\mu$ f. If section C2 is a cutaway designed especially for 456 kc, then no padding condenser C5 is required. In this case the end of the coil

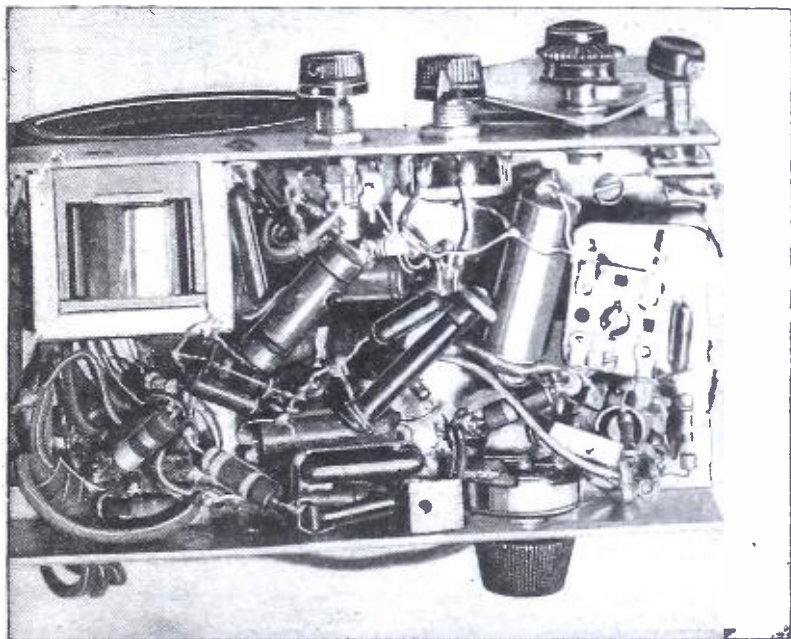

Underchassis view of the Super-Reflex above, schematic diagram below.

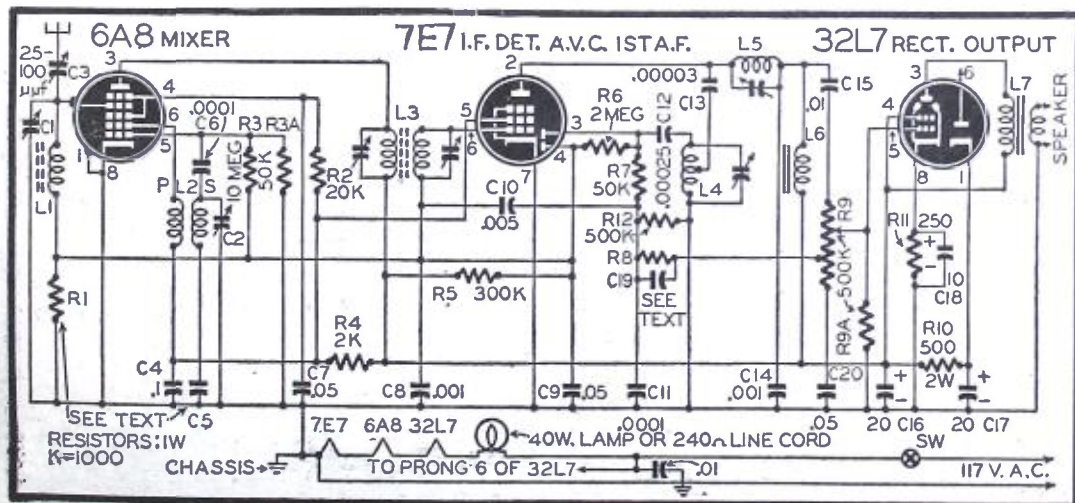

W. T. Connatser was born in Tennessee. He was called to duty in the army as a captain at the beginning of World War I, and was mustered out a lieutenant colonel in 1920. Was chief of subsistence division of the AEF in France 1918-19, and was with the Allied High Commissioner in Transcaucasia on relief duty 1919-20. Commissioned a captain in the regular army in 1920, he is an honor graduate of the QMC Subsistence School 1923-24, and a graduate of the Army Industrial College 1927-28. Was retired from active duty in 1934 for disability contracted in line of duty. In addition to American decorations, he received the Officer of the Crown from the King of the Belgians and the Bronze Medal from the Near East Relief. His hobby since retirement from the army: building radio sets of new or unusual design.

shown attached to C5 is connected directly to ground instead.

Neither L1 nor L2 need be shielded if one is mounted above and one below the chassis.

The first i.f. transformer is a 456 kc iron core factory job. It should be good quality, and generally will be pre-tuned when purchased. This is important, as will be explained later.

The coils L4 and L5 make up the second i.f. coupler. L4 has a center tap to which condenser C13 is attached. In the beginning we made up L4 from a small radio frequency choke, and L5 from the primary winding of a radio frequency coil. Small compression type condensers were used to tune the coils. Condenser C13 was attached to the top of L4 with this early coil. Later we purchased replacement windings for a 456 kc i.f. transformer, one of the coils containing the center tap. The mounting

(Continued on page 422)



# NEW RADIO PATENTS

## VOLTAGE REGULATOR

Hans Klemperer, Belmont, Mass.  
Patent No. 2,383,492

IN certain applications such as welding it is necessary that the voltage be kept within definite limits. An instantaneous and positive acting regulating circuit is required.

As shown, the circuit uses three VR tubes and a gas-filled triode. Alternating current is applied through a transformer and the triode to the condenser, C. The latter voltage, for example 3000, is to be controlled. The VR tubes may operate at 105 volts and fire at 110 volts.

The potentiometer is adjusted so that the VR tubes fire when the desired voltage across C is reached. At this instant a voltage of 15 appears across R [3 x (110-105)]. Any additional voltage at point P is then simply added to the voltage across R because of the VR tube action.

The voltage across R constitutes a negative bias for the triode. Therefore, the current

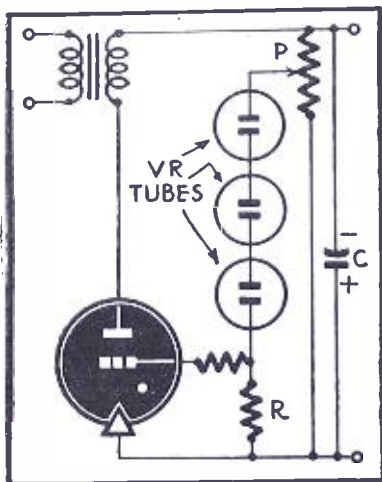

through the tube is sharply controlled. Curve (R) shows the characteristic when a single VR tube is used, (S) when three tubes are used, and (T) when only a potentiometer is used.

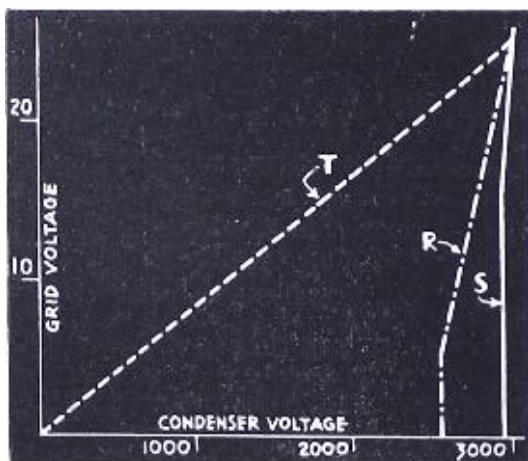

## RELAY CIRCUIT

William E. Simpson, So. Ozone Park, N. Y.  
Patent No. 2,387,536

ALTHOUGH operated from on-off signals, this polarized relay shows push-pull characteristics; current flows through it in both directions.

When a signal is received the full-wave rectifier delivers a negative voltage to the triode grid, biasing the tube to cut-off. The rectifier load includes resistor R and the relay winding. Polarity of the latter is as marked. When the signal stops, the rectifier output disappears. The triode then conducts and plate current flows through the relay winding in the reverse direction so that its polarity is opposite to that

which is marked. The armature is attracted to one pole or the other depending upon current direction.

This circuit has been found useful in connection with printer code signals transmitted over large lines or radio channels. Such signals may be distorted and will not easily affect a teletype printer. If the present circuit is adjusted

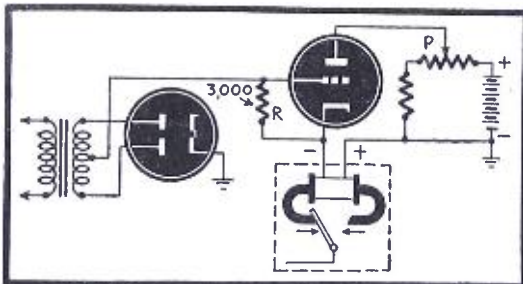

so that weak signals cut off the triode and if the reverse current is properly adjusted by means of the potentiometer, it will be actuated by such signals.

## TEMPERATURE CONTROL

Walter P. Wills, Philadelphia, Pa.  
Patent No. 2,375,159

IN the operation of any indicating instrument, there is a choice of making it quick-acting with probable overshooting or slow-acting with a gradual approach to the final mark. In this device, which is used to control and record oven temperature, an initial impulse is provided in addition to the normal force, resulting in rapid response while eliminating overshooting.

The voltage output of a thermocouple due to temperature variations is an alternating component superimposed over a direct current. As shown in the figure this is applied across a center-tapped 200-ohm resistor. The upper half, R1, is associated with an auxiliary circuit containing a condenser and potentiometer which can pass the A.C. component only.

While the temperature remains constant, the voltage across A and B equals that across R2. When a rise or drop occurs, the output is momentarily increased or decreased by the voltage across the potentiometer. As the condenser reaches its final state of charge this latter A.C. component disappears.

The swinging-mirror galvanometer G measures the voltage across A, B and R3 in series. The former is the thermocouple output and the latter is due to an external battery. R4 is adjusted so that at normal oven temperature the two voltages are equal and G does not deflect.

As the oven heats or cools, G swings in one direction or the other so that more light falls

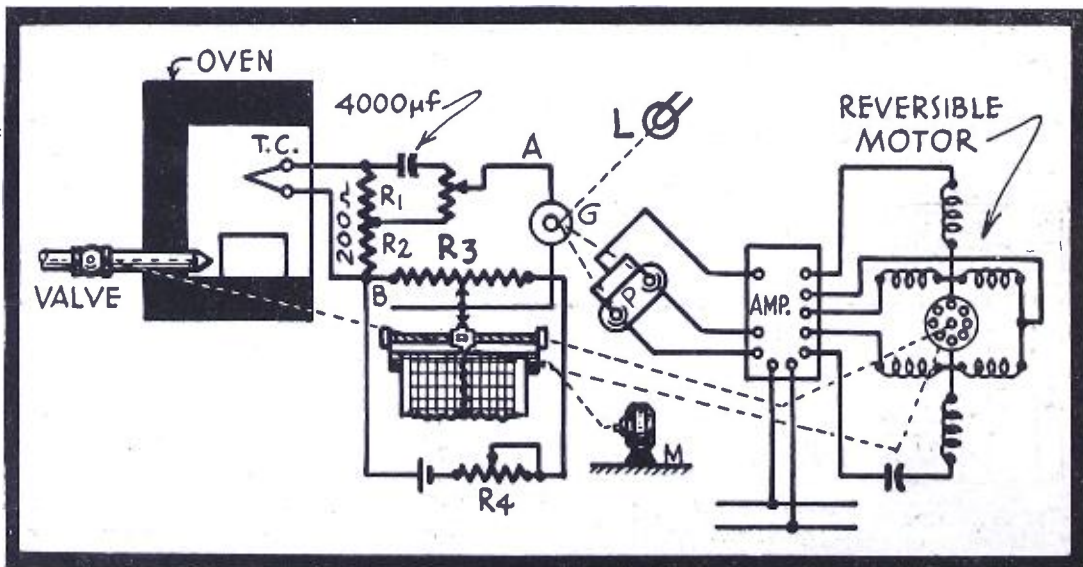

on one or the other of the photocells P. The unbalanced voltage is amplified in a D.C. amplifier and applied to a reversible motor.

The motor is connected with the threaded shaft as well as the oven valve. Contact T moves in the corresponding direction for making a permanent record, while the valve adjusts the fuel intake to restore normal conditions. Another motor M runs the recording chart.

## MULTIPLE CARRIER CURRENT SYSTEM

John L. Woodworth, Schenectady, N. Y.  
Patent No. 2,385,673

WHEN it is desired that each transmitter of a carrier current system cause response only in its associated receiver some means is necessary to exclude signals from the other transmitters.

In the figure shown, transmitter A should not operate receiver B. To accomplish this, transmitter B is placed between the two and a series resonant circuit is connected. This circuit is composed of two condensers and two coils and is tuned to transmitter A frequency, thus effectively short-circuiting it. Receiver B therefore does not respond to transmitter A. L indicates the inductance of the carrier current generator and is made equal to L0 so that the wave trap operates whether the transmitter is on or off.

The procedure is followed for transmitter B.

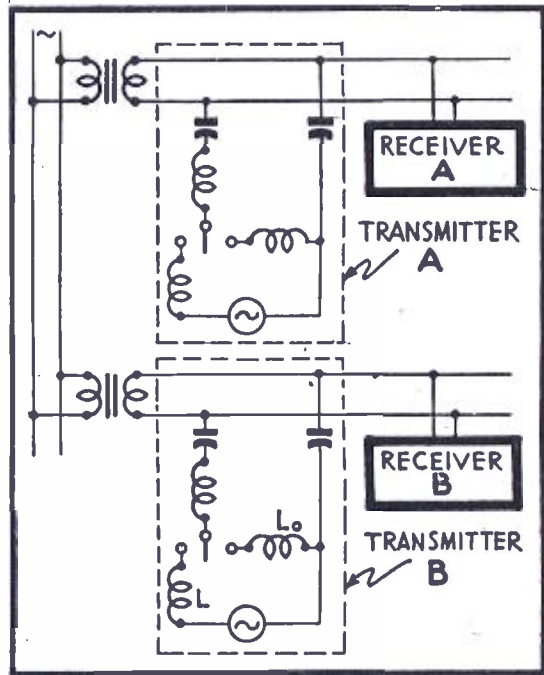



# Here it is!

• Photographic view of the CALIFORNIA KILOWATT in open position and ready to transmit or receive.

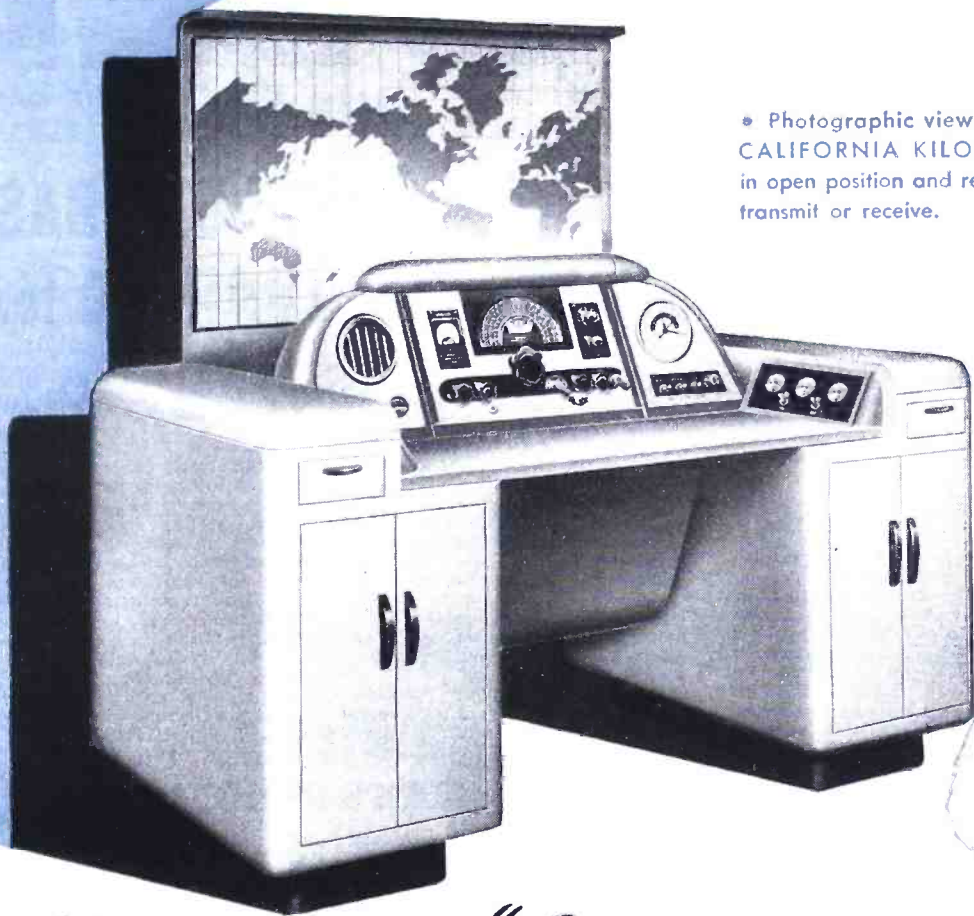

## The **KLUGE** "California Kilowatt"

Myron E. Kluge, President of Kluge Electronics, Inc., proudly presents to the radio amateurs of the world a new sensation in radio history, The CALIFORNIA KILOWATT—a "one package" 1000 watt amateur radio station designed and engineered to bring amateur radio out of the attic and the shack and into the living room.

About the size of an ordinary desk, the CALIFORNIA KILOWATT is simply and beautifully designed to fit into your den or living room as neatly and harmoniously as an additional piece of furniture with no clutter or mess. It is completely self-contained with nothing to be added.

Kluge Electronics, Inc., is the first to conceive, design and produce this remarkable contribution to modern radio. Among the special Kluge features designed into the CALIFORNIA KILOWATT are:

1. A California Kilowatt transmitter with an amazing new tube development—5 band operation with variable frequency control in each band—phone or CW at the throw of a switch—110 or 220 volt operation;
2. Provisions for your choice make of receiver;

3. Built-in speaker — (high fidelity remote speaker also available);

4. Built-in frequency monitor—all band crystal controlled;

5. Built-in world time clock;

6. Illuminated world map with cork backing;

7. Price—the complete CALIFORNIA KILOWATT Station costs far less than you would expect to pay for a transmitter alone.

Premiere showings of the Kluge CALIFORNIA KILOWATT will be held in key cities soon throughout the nation by America's leading wholesale distributors. For additional information about the CALIFORNIA KILOWATT write to Kluge Electronics, Inc., Dept. E1, 1031 N. Alvarado Street, Los Angeles 26, Calif.



The CALIFORNIA KILOWATT in closed position

**KLUGE**  
ELECTRONICS INC.

A few territories are still available to qualified distributors. Write or wire Kluge Electronics, Inc.



# I'LL HELP YOU TO EQUIPMENT EVER

**ALFRED A. GHIRARDI**  
the man who has started thousands of students on successful careers by making Radio-Electronics easy to learn.

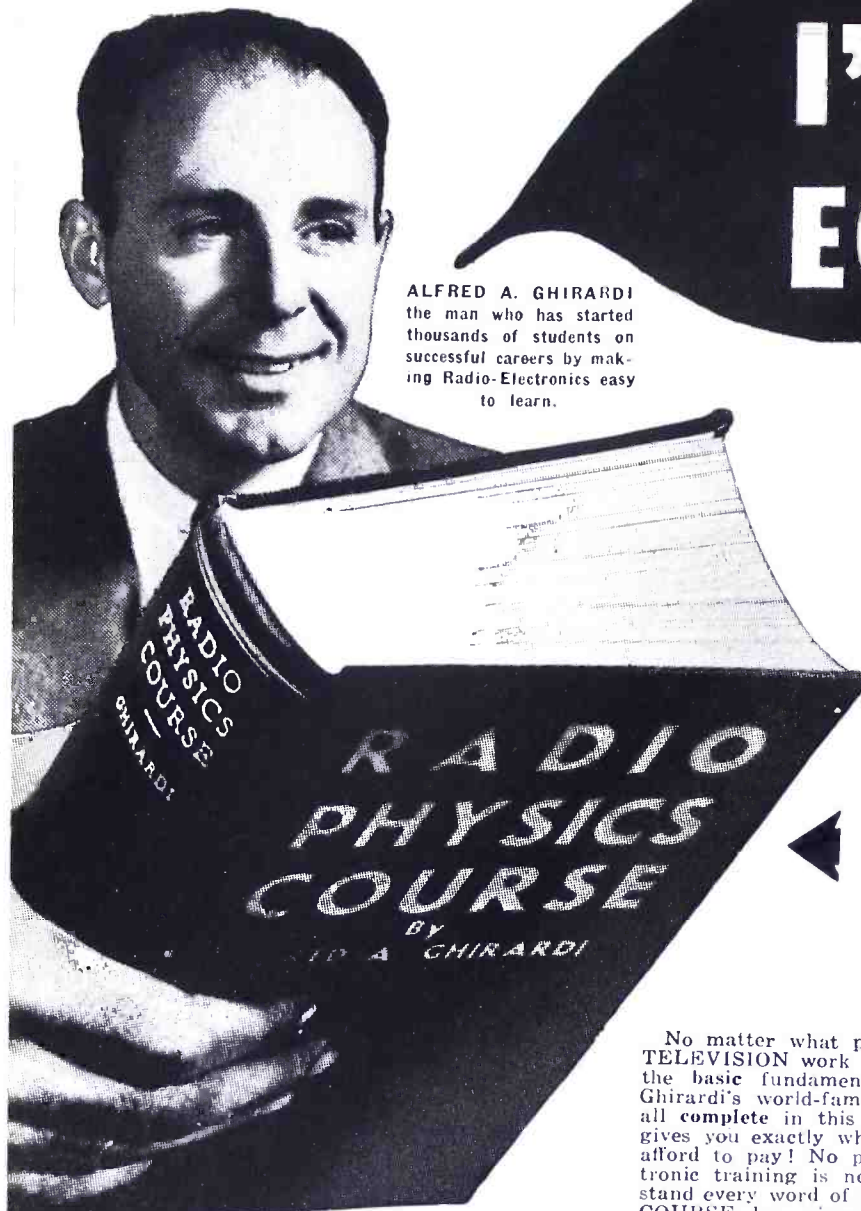

A FEW NIGHTS OF **THIS** CAN PAVE THE WAY TO A PROSPEROUS FUTURE OF **THIS**

## Ghirardi's COMPLETE BASIC RADIO-ELECTRONIC TRAINING for Beginners

for only **\$5** (\$5.50 foreign)

No matter what phase of ELECTRONICS-RADIO-TELEVISION work you plan to enter, a knowledge of the basic fundamentals is absolutely essential—and Ghirardi's world-famous RADIO PHYSICS COURSE, all complete in this one big 4-pound, 972-page book, gives you exactly what you need—at a price you can afford to pay! No previous electrical, radio, or electronic training is necessary to enable you to understand every word of it! Remember! RADIO PHYSICS COURSE has given more beginners their start in Radio-Electronic work than any other book or course ever published! Let it do the same for you!

RADIO PHYSICS COURSE starts your training right at the very beginning—with Basic Electricity. Then it takes you step by step through the entire field of RADIO-ELECTRONICS-TELEVISION to the latest, most modern developments. Nothing is omitted, nothing condensed. Everything is clearly and thoroughly explained.

Everything is made as simple as A-B-C. Ask any successful Radio-Electronic man about it. He'll know the book—because he probably got started from it himself!

This single, fully-illustrated 972-page volume is a miracle of modern Radio-Electronic training written by an author who has devoted years to making radio easy for beginners. Actually, it gives you the scope of 36 different courses in one. If broken into "course" form and sent to you in monthly lessons, you'd regard it as a bargain at \$50 or more! Instead, you buy it for only \$5—and you progress as fast as spare reading time permits you. Many students have completed it within a few weeks!

If you're just starting in Radio and want to get started right **THIS IS THE BOOK FOR YOU**—and we back it with our **5-DAY MONEY-BACK GUARANTEE** that makes you the sole judge of whether or not you will want to keep it! You cannot lose!

**The Book That Makes It Easy to Learn at Home**

**NO PREVIOUS TRAINING NEEDED!**

**Covers Basic Radio-Electronics Like a Blanket**

36 Big Courses in One! Here are a few of the things about which

Ghirardi's big **RADIO PHYSICS COURSE**

book teaches you

- |                       |                                    |
|-----------------------|------------------------------------|
| Sound, Speech, Music  | Detector and Amplifier Tube Action |
| Electron Theory       | Radio-Frequency Amplifiers         |
| Electric Current      | Superheterodynes                   |
| Electric Circuits     | Audio Amplifiers                   |
| Resistance            | Power Supplies                     |
| Batteries             | Loud Speakers                      |
| Electromagnetism      | Auto & Aircraft Radio              |
| Electromag-Induction  | Aviation Radio                     |
| Condensers, Coils     | Public Address Systems             |
| Alternating Currents  | Phototubes, Cathode Ray Tubes      |
| Transformers          | Sound Pictures                     |
| Filters               | Television, etc., etc.             |
| Measuring Instruments |                                    |
| Radio Waves           |                                    |
| Vacuum Tubes          |                                    |

*Radio Physics Course is more widely used for home study, by more Signal Corps, Navy, and civilian schools and colleges than any other book of its kind!*

### Wishes He'd Bought It Sooner!

"I only wish I had known about RADIO PHYSICS COURSE sooner. I have already learned more from only a few pages than I got from almost two years of intermittent study from other sources."  
Richard L. Lucas, Fort Worth, Texas.

### Compares It with a \$150 Radio Course

"I had already taken a \$150 radio course but since I've read RADIO PHYSICS COURSE, I put the other one away. RADIO PHYSICS COURSE is the real book I need, because it teaches so clearly."  
Gerard Champagne, Montreal, Canada.

### Easy to Understand

"One of the clearest, easiest books for the beginner I have ever read."  
Jerome Feld, Brooklyn, N. Y.

"I have read quite a few texts on Radio-Electronics. Now after reading RADIO PHYSICS COURSE, I can see that I wasted my time on the other ones!"  
C. W. Redish, Astoria, Oregon.



## Learn All About TELEVISION PROGRAMMING and PRODUCTION

Not since the early days of the movies or of Radio itself has there been such a glowing opportunity to get in on the "ground floor" of a vast new industry as Television now presents. Television's technical problems are fast being solved. Today, the crux of its development problems is the matter of producing the right kind of programs—and in his new book, **TELEVISION PROGRAMMING AND PRODUCTION**, Richard Hubbell, Production Manager and Television Consultant of Crosley Corp., not only explains for you every phase of this important new

field in television work, but outlines potential developments as well.

Technical limitations and possibilities are discussed from the all-essential program standpoint. Writing—acting—directing—advertising—production—designing—and Television's relation to the theatre and the movies are but a few of the subjects covered. Fifty selected photos illustrate the different production techniques and provide in themselves a complete, graphic course in this latest of the Arts. The very first book of its kind! 207 pages. Price \$3 (\$3.25 foreign).

**ENJOYABLE — INSTRUCTIVE — EASY TO UNDERSTAND**

# GHIRARDI TRAINING TO SAVE YOU LEARN EASIER, BETTER, FASTER...



# REPAIR ANY RADIO-ELECTRONIC MADE ... AND GUARANTEE TO REFUND EVERY CENT OF YOUR MONEY IN FIVE DAYS IF YOU'RE NOT SATISFIED!

## THIS 4½ LB. HANDBOOK SHOWS YOU EXACTLY HOW TO REPAIR OVER 4,800 RECEIVER MODELS

**A Definite, Dependable Guide for Diagnosing, Locating and Repairing the Common Troubles in Almost Every Receiver Ever Made.**

**GHIRARDI TELLS YOU WHAT TO DO—EXACTLY HOW TO DO IT**

Whether you repair radios for a living or work with them only occasionally, Ghirardi's **RADIO TROUBLESHOOTER'S HANDBOOK** will help you do the jobs better **AND TWICE AS FAST**. Eliminates useless testing! Saves time—helps you make more money! When a receiver comes in for repairs you simply turn to the 404-page Case History section of the Handbook. Look up the notes on that particular make and model—and, chances are, you'll find **EXACTLY** the information you require. The Handbook tells you what the trouble is—how to remedy it. Just the thing for training and speeding up the work of new service helpers—handling tough jobs in half the usual time—repairing cheap sets rapidly and profitably.

### WORK TWICE AS FAST!

The tabulations on hundreds of additional pages give you invaluable data on Color Codes, Tubes, I-F alignment and transformer troubles, tube substitutions, etc. The literally dozens of charts, graphs, diagrams, data and helpful hints will save you money every day you use them!

"Thanks to Ghirardi's Handbook, I repaired my radio in one hour after it had been returned as 'unrepairable' from a local shop," writes J. L. Fizzell, Kansas City, Mo.

"I would not take ten times the price my Handbook cost me," says C. E. Daniels, Bartow, Florida.

"Started to work for me the first day I bought it. The Case Histories take you right to the trouble and save headaches and hours of testing," says Julius Siske, Jr., Curtis Bay, Maryland.

Ghirardi's big Handbook weighs 4½ lbs., contains 744 big manual-size pages. Only \$5 complete—on our 5-Day Money-Back Guarantee offer!



**Only \$5 complete**  
(See money-saving offer in coupon)

### STOP GUESSING, MISTER!

Don't guess! Don't waste time! Turn to GHIRARDI'S big Radio Troubleshooter's Handbook—let it tell you in a jiffy **WHAT** to do and **HOW** to do it.

## A COMPLETE MODERN Professional SERVICE TRAINING ... at Home Without an Instructor

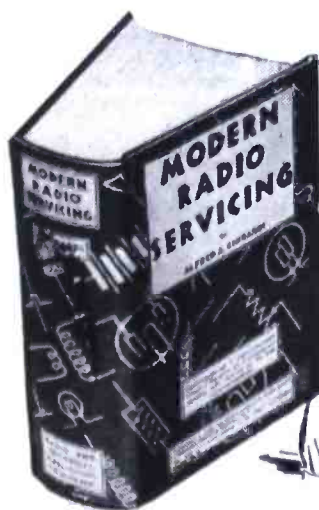

Now, as never before, the call is for **PROFESSIONALLY TRAINED** men who really **KNOW** radio repair work.



A. A. Ghirardi's **MODERN RADIO SERVICING** is the finest, most complete instruction book on Radio-Electronic service work for either the novice or the professional serviceman—bar none! Actually, it gives a **COMPLETE MODERN EDUCATION** in truly professional service work of the kind that will be your "Open Sesame!" to the real opportunities in Radio-Electronic servicing springing up on every side. Remember! The call is now for **HIGHLY TRAINED** men having a broad knowledge of modern test equipment and testing techniques—**NOT** for "screw-driver" mechanics of only limited ability and technical understanding!

Read from the beginning, **MODERN RADIO SERVICING** is a complete servicing course from A to Z. Used for reference, it is an invaluable refresher course on any type of work that puzzles you. Explains all types of test instruments used in Radio-Electronic service work—also how, when, why and where to use each one; how to make preliminary trouble checks and perform circuit analysis; how to repair or replace parts or make substitutions—and literally hundreds of additional subjects including How to Start and Operate a Successful Service Business of Your Own. 1300 pages, 706 clear illustrations, 720 self-test review questions.

Only \$5 complete  
(See money-saving offer in coupon)

### START A SERVICE BUSINESS ... OR GET A BETTER-PAYING JOB!

There's a real future for you in servicing—and A. A. Ghirardi's **MODERN RADIO SERVICING** is just the book to start you on it without delay. And remember: Radio itself only represents the beginning of this big book's usefulness to you. What it teaches you about Radio Servicing, Test Instruments and Modern Scientific Technical Procedure is exactly the training you need to fit you to "grow up" with the fast-expanding Electronics profession in all of its

servicing phases. The amount of Radio and Electronic equipment that will be manufactured and sold both to industry and the public within the next few years will be tremendous. All of it must be serviced—and there'll be rich rewards for competently trained men who can fill the bill! **MODERN RADIO SERVICING** gives you real Professional service training—complete in every respect—easy to understand—and priced at only \$5 complete!

### FIVE DAY UNRESTRICTED MONEY BACK GUARANTEE

**MURRAY HILL BOOKS, Inc., Dept. RC-36**  
232 Madison Ave., New York 16, N. Y.

- Enclosed find \$ - - - for books checked; or  send C.O.D. (in U.S.A. only) for this amount plus postage. In either event it is understood that I may return the books for refund of my money within 5 days if not fully satisfied.
- RADIO PHYSICS COURSE** \$5 (\$5.50 foreign)
- TELEVISION PROGRAMMING & PRODUCTION.** \$3 (\$3.25 foreign)
- MODERN RADIO SERVICING** \$5 (\$5.50 foreign)
- RADIO TROUBLESHOOTER'S HANDBOOK,** \$5 (\$5.50 foreign)
- MONEY-SAVING COMBINATION OFFER:** Modern Radio Servicing and Troubleshooter's Handbook—both big books—\$9.50 (\$10.50 foreign).

NAME \_\_\_\_\_  
ADDRESS \_\_\_\_\_  
CITY AND DISTRICT NO. \_\_\_\_\_ STATE \_\_\_\_\_

**TIME & MONEY**  
Mail coupon now!



### MONEY-SAVING COMBINATION

Make your servicing library complete! Get BOTH Ghirardi's **RADIO TROUBLESHOOTER'S HANDBOOK** and **MODERN RADIO SERVICING** at the special Money-Saving Combination price of only \$9.50 for both (\$10.50 foreign). Use coupon today!









# Where Will YOU Be in 1950?

## Enjoy Security and Good Pay! Prepare Now With CREI Modern Technical Training and Step Ahead of Competition into a Good Job!

*CREI Offers You a Proved  
Program of Self-Improvement to Keep Pace with  
Modern U.H.F. Advancements and Enables You to  
Go After — and Get a  
Secure Radio Job!*



Yes, there are GOOD JOBS . . . for GOOD men! The easy jobs are gone and once again knowledge and ability are the requirements for the good-paying jobs. Competition is opening up. The fight to HOLD good jobs—to SECURE better ones is just starting. Employers once again can afford to be "choosy" . . . to select the best man for the best job. In the face of this show-down situation—*where do YOU stand?*

CREI home study training in Practical Radio-Electronics Engineering can equip you to meet the requirements to *hold* your job—or advance to a *better* one. No matter what your past radio-electronics experience has been—no matter what your training—you must actually start anew to gain the confidence born of knowledge. By adding CREI training to your present radio experience you can safeguard your future and keep pace with such new developments as U.H.F. Circuits, Cavity Resonators, Pulse Generators, Wave Guides, Klystrons, Magnetrons and other tubes. Are you equipped to handle them? CREI is

equipped to *help you*, by providing the know-how and ability that is required.

In our proved method of instruction, you learn not only *how* but *why!* Easy-to-read-and-understand lessons are provided well in advance, and each student has the benefit of personal guidance and supervision from a trained instructor. This is the basis of the CREI method of training for which many thousand professional radiomen have enrolled since 1927.

It's up to you now to decide your course. What you do today will be the answer to where you will be in 1950 and the years after. It costs you nothing to read the interesting facts . . . to learn how CREI can help you enjoy the security you want . . . the better-paying job that can be yours. Write for particulars *now!*

## CAPITOL RADIO Engineering Institute

HOME STUDY COURSES IN PRACTICAL RADIO-ELECTRONICS  
ENGINEERING FOR PROFESSIONAL SELF-IMPROVEMENT

Dept. RC-3, 3224—16th Street, N. W., Washington 10, D. C.

Contractors to U. S. Navy—U. S. Coast Guard—Canadian Broadcasting Corp.  
Producers of Well-trained Technical Radiomen for Industry.

• WRITE  
TODAY for  
FREE  
BOOKLET



"Your Opportunity in the  
New World of Electronics"

If you have had professional or amateur experience—let us prove to you that we have something you need to qualify for a better radio job. To help us to intelligently answer your inquiry—PLEASE STATE BRIEFLY YOUR BACKGROUND OF EXPERIENCE, EDUCATION AND PRESENT POSITION.

Member: NATIONAL COUNCIL OF TECHNICAL SCHOOLS





## Wave Makers

"A leaping trout awakens the still pool to life in waves that move in silent rhythm."

In the same way, when you speak over the telephone, vibrating electric currents speed silently away with the imprint of your voice over the wire and radio highways of the Bell System.

Tomorrow, the vibrations will be the living pictures of television. All are examples of wave motion.

How to produce, transmit and receive electrical wave motion is the basic problem of the communication art.

Bell Telephone Laboratories, which exist primarily to invent and

develop better communications for the Bell System, devote the teamed efforts of physicists and mathematicians to the production and control of electric waves in all forms.

Out of these fundamental studies have come the discoveries which keep the Bell System at the forefront of the communication art.



**BELL TELEPHONE LABORATORIES**



## POSTWAR RECEIVING TUBE

**P**ERHAPS no receiving type of electronic tube introduced within the immediate past has captured the interest and imagination of electronic engineers so completely as the 6AK5, first manufactured by the Western Electric Company and its subcontractors. This miniature pentode stems from the 384-A and 386-A tubes designed by Bell Telephone Laboratories for broad-band, high-frequency amplification essential to coaxial cable systems.

At the beginning of the war, when circuit engineers were searching for a small tube to use with high-frequency circuits for the Armed Forces, their associates in electronic development offered them an adaptation of a tube which was developed for broad-band carrier systems. This adaptation was the 6AK5. The tube successfully fitted the vital requirements of high transconductance, low capacitances, low noise, and high input resistance.



The 6AK5 is a pentode tube with indirectly heated cathode and has the suppressor grid tied internally to the cathode. It is capable of providing better than twice the signal-to-noise ratio obtainable with any tube previously available for use as an intermediate-frequency amplifier at frequencies of the order of 50 megacycles. However, the 6AK5 is capable of operating satisfactorily at frequencies up to approximately 350 megacycles.

The important characteristics of high transconductance, low noise, and high input resistance of the 6AK5 at the higher frequencies are fundamentally dependent upon the spacing between the cathode and the grid which is in the order of 0.0035-inch. Minimum lead inductance has been obtained by mounting the structure close to the 7 pin-button stem.

Listed below are the characteristics of the 6AK5 vacuum tube:

Maximum Diameter.....	3/4 inch
Maximum Seated Height.....	1 1/2 inch
Classification .....	Pentode
Type of Cathode .....	Indirectly Heated
Filament or Heater Voltage.....	6.3 volts
Filament or Heater Current.....	0.175 amp.
Normal Plate Voltage .....	120 volts
Normal Screen Voltage .....	120 volts
Normal Grid Voltage .....	2 volts
Normal Plate Current .....	7.5 ma.
Normal Screen Current .....	2.5 ma.
Normal Transconductance .....	5000 $\mu$ mhos
Input Capacitance (with shield)....	4.0 $\mu$ mf
Output Capacitance (with shield)...	2.0 $\mu$ mf
Plate-grid Capacitance (with shield)	0.01 $\mu$ mf

## In this NEW WORLD OF ELECTRONICS

Will you go *Forward-*  
or *Backward?*



**TO GET AHEAD YOU  
MUST STUDY NOW**

**NEW ELECTRONIC TECHNIQUES**—War-born developments equivalent to 20 years of research are here. Your future demands that your technical knowledge be modernized to keep pace with these new developments.

**THE EXACTING DEMANDS OF POST-WAR EMPLOYMENT** require that you "deliver the goods." Employers can afford to be "choosy"—only the technically qualified can expect to pass the screening tests for the better jobs. "What Do You Know?" will be the hurdle you will have to leap. Pulse-shaping techniques—cavity resonators—pulse time modulation—single sideband multitone multiplex transmission—these are commonplace terms in this New World of Electronics. Do you know these or similar new techniques?

**MORE THAN EVER BEFORE**, a sound basic knowledge of up-to-date, fundamental engineering to radio-electronics is an essential to a better job—promotion—**increase in pay.**

**LET CIRE TAKE OVER YOUR PERSONAL UP-GRADING PROBLEM!** Qualified, competent instructors, ample, personalized instructional aids, orderly, progressively arranged study assignments in recognized, approved technical texts—these are only a few of the many superior advantages of CIRE's plan of personalized spare-time home study training for professional self-improvement.

CIRE HOME STUDY COURSES COVER THE FIELD OF RADIO-ELECTRONICS—TELEVISION, ULTRA-HIGH FREQUENCY TECHNIQUES, AM AND FM BROADCASTING, COMMUNICATIONS ENGINEERING—from simple treatment of fundamentals, through preparation for FCC commercial radio operators' license examinations, up to and including complete high level quantitative treatment of advanced radio-electronics and communications engineering. Choose the course best suited to your needs, and start with the section you are qualified to enter. You pay for only the section or sections you need. Use the "Pay-as-you-go plan" patterned after ethical, educational practice. These features are unique with Cleveland Institute, and represent the best in the modern, post-war concept of home study training.

Many CIRE students of advanced engineering courses today are broadcast chief engineers. Graduates of CIRE courses are eligible for the top jobs in radio-electronics.



Write today for free, descriptive booklet. "THIS NEW WORLD OF ELECTRONICS HOLDS OPPORTUNITY FOR YOU." No obligation—no salesmen.

## CLEVELAND INSTITUTE of RADIO ELECTRONICS

Successors to

NILSON RADIO SCHOOL, Founded 1939

SMITH PRACTICAL RADIO INSTITUTE, Founded 1934

**RC-3 TERMINAL TOWER . . . . CLEVELAND 13, OHIO**

MAIL THIS COUPON.

### CLEVELAND INSTITUTE of RADIO ELECTRONICS

RC-3 Terminal Tower, Cleveland 13, Ohio  
Gentlemen: Please send information about your home study courses in Radio Electronics.

NAME .....

ADDRESS .....

CITY .....

ZONE ..... STATE .....

I desire training in .....

I have had experience in broadcasting  servicing  operating  mfg.  CAA  Army-Navy  amateur  other .....

I am a High School Grad  College Grad

I hold a ..... degree in .....



**AUDELS REFRIGERATION & AIR CONDITIONING GUIDE . . . . . \$4**

New from Cover to Cover—1280 Pages, Fully Illus. Covering basic principles, servicing, operation & repair of household, commercial & industrial refrigeration & air conditioning. A gold mine of essential important facts for engineers, servicemen, shopmen & users.

**AUDELS SHEETMETAL PATTERN LAYOUTS . . . . . \$4**

Developed by Experts for Sheet Metal Workers, Layout Men & Mechanics. A Practical Encyclopedia in 10 Sections, size 7 x 10 x 2—1125 Pages—350 Layouts—1600 Illustrations. 1001 Key Facts. Fully indexed for ready reference in answering your layout problems. Covers all phases of sheet metal work including Pattern Cutting, Pattern Development & Shop Procedure.

**AUDELS SHEETMETAL WORKERS HANDY BOOK . . . . . \$1**

Practical inside information. Fundamentals of Sheet Metal Work. 388 pages. Fully illustrated. 11 sections. Clearly written. Essential & important facts, figures, pointers in everyday language. Ready Reference Index.

**AUDELS WELDERS GUIDE . . . . . \$1**

A concise, practical text on operation and maintenance of all welding machines for all mechanics. Over 400 pages, fully illustrated. Covers all methods of electric and acetylene welding including airplane work.

**AUDELS ANSWERS ON BLUE PRINT READING . . . . . \$2**

For Mechanics & Builders. Covers all types of blue print reading including ship & airplane. 376 pages, fully illustrated. New, complete.

**AUDELS NEW MACHINIST & TOOLMAKERS HANDY BOOK . . . . . \$4**

Covers modern machine shop practice in all its branches. 5 practical books in 1. New from cover to cover. Tells how to set up & operate lathes, screw and milling machines, shapers, drill presses and all other machine tools. 1600 pages, fully illustrated, 5 x 6 1/2 x 2. Indexed. 5 sections. 1—Modern Machine Shop Practice. 2—Blue Print Reading & How to Draw. 3—Calculations & Mathematics for Machinists. 4—Shop Physics. 5—How to Use the Slide Rule. 60 chapters. Easy to read and understand. A shop companion that answers your questions.

**AUDELS MATHEMATICS & CALCULATIONS FOR MECHANICS . \$2**

Mathematics for home study or reference. 700 pages, 550 illustrations. Practical mathematics from beginning. How to figure correctly. New, easy, correct methods covering a complete review. Illustrated & indexed.

**AUDELS AUTOMOBILE GUIDE . . . . . \$4**

A practical quick ready reference book for auto mechanics, service men, operators & owners. Explains theory, construction and servicing of modern motor cars, trucks, buses & auto type Diesel engines. 1540 pages, fully illustrated. 55 chapters. Indexed. A standard book for mechanics.

**AUDELS DIESEL ENGINE MANUAL . . . . \$2**

A practical, concise treatise with questions and answers on the theory, operation and maintenance of modern diesel engines including General Motors 2 cycle Diesel. 384 pages, fully illustrated, flexible binding, pocket size. All details plainly brought out, this book is of extreme value to engineers, operators & students.

**AUDELS SHIPFITTERS HANDY BOOK . \$1**

288 pages of information, instruction, pictures & reference charts, together with many short cuts & trouble savers for shipfitters in their work.

**AUDELS RADIOMANS GUIDE . . . . . \$4**

A key to the practical understanding of radio including Frequency Modulation, Television, etc., Aircraft & Marine Radio. For radio engineers, servicemen, amateurs. 772 pages. 400 Illustrations & Diagrams. Photos. Review Questions & Answers, Reference Index. Authentic, clear, concise.

**AUDELS MECHANICAL DICTIONARY . \$4**

950 pages. Over 17,000 new and standard mechanical terms, words, phrases, tables, formulas, helps, hints, short-cuts and practical suggestions. The right word when needed most.

**AUDELS HANDY BOOK OF PRACTICAL ELECTRICITY . . . . . \$4**

For maintenance engineers, electricians & all electrical workers. 1440 Pages, 2600 Illustrations. Covers important electrical information in handy form—including Marine Wiring, Radio Principles, Welding. Fully indexed. The key to a practical understanding of electricity.

**AUDELS CARPENTERS & BUILDERS GUIDES—4 Vols. . . . . \$6**

A practical illustrated trade assistant on modern construction for carpenters, joiners, builders, mechanics and all woodworkers. 4 vols., 1800 pages, 3700 illustrations, flexible covers. Each volume pocket size. Sold separately \$1.50 a vol.

**AUDELS PLUMBERS & STEAMFITTERS GUIDES—4 Vols. . . . . \$6**

A Practical Trade Assistant & Ready Reference. Explaining in plain language & by clear illustrations, diagrams, charts, graphs, pictures the principles of modern plumbing practice including Marine Pipe Fitting and Air Conditioning. 4 Vols.—1670 Pages—3642 Diagrams. Each Vol. Pocket Size. Sold Separately \$1.50 a Vol.

**AUDELS WIRING DIAGRAMS . . . . . \$1**

210 Pages, Illustrated. Gives practical facts on wiring of electrical apparatus. It explains clearly in simple language how to wire apparatus for practically all fields of electricity. Each diagram is complete & self-explanatory. A Highly Endorsed Pocket Companion.

**AUDELS ELECTRIC DICTIONARY . . . . \$2**

For Every Worker Who Has To Do With Electricity. Enables you to understand and explain electrical problems. Defines more than 9000 words, terms & phrases in plain, unmistakable language, compiled with accuracy & thoroughness. Alphabetically arranged, reference index.

**AUDELS MILLWRIGHTS GUIDE . . . . . \$4**

Practical up-to-date Information on Plant Installation, Operation and Maintenance. 1200 pages completely illustrated, fully indexed. 1000 facts at your fingertips in 6 convenient sections with ready reference.

**GUETHS MECHANICAL DRAWING . . . \$1**

A Concise Drawing Course. 150 pages, 50 plates. A complete instructor & reference work. Gives many helpful hints & suggestions on How to Draw.

**AUDELS ELECTRONIC DEVICES . . . . \$2**

Tells What You Want to Know About Electric Eye. Easily Understood. Covering photo-electric cells & their applications. Amplifiers, illumination, frequencies, voltage, photocell, tubes, Ohm's Law, wiring diagrams, etc.

**AUDEL, PUBLISHERS, 49 W. 23 St., N.Y.**



**Information in a Handy Form! AN AUDEL GUIDE IS A GOOD FRIEND!**

Use the brains and experience of others in these Guides of the Trades. Save time and money with right methods, short cuts, labor-saving ideas—"Learn more to earn more." Use our generous 7-day free examination privilege and our dollar a month payment plan. Become a Master in your Trade, and understand the Trades that tie into yours.

How to obtain these Guides for examination. Mark X on the order blank the Guides desired. Every Audel Guide is complete, up-to-date, easily understood with Questions and Answers, fully illustrated and indexed. They speak for themselves. Send for yours today at our risk and expense. Ask to see them.



**Check NOW!**

You Can Look Over Any Guide In Your Own Home

Start the Easy Payments If Satisfied

**MAIL THIS TODAY**

**CUT HERE MAIL ORDER**

THEO. AUDEL & CO., 49 W. 23 St., New York 10, N.Y.

Please mail me for 7 days' free examination the books marked (X) below. I agree to mail \$1 in 7 days on each book or set ordered, and to further mail \$1 a month on each book or set ordered until I have paid purchase price.

If I am not satisfied with Guides I will return them.

- Audels REFRIGERATION & Air Conditioning Guide . \$4.
- Audels POWER PLANT ENGINEERS GUIDE . 4.
- Audels PUMPS, HYDRAULICS & AIR COMPRESSORS . 4.
- Audels WELDERS GUIDE . 1.
- Audels BLUE PRINT READING . 2.
- Audels SHEET METAL WORKERS Handy Book . 1.
- Audels SHEET METAL PATTERN LAYOUTS . 4.
- Audels AIRCRAFT WORKER . 1.
- Audels MATHEMATICS and CALCULATIONS . 2.
- Audels MACHINISTS & TOOLMAKERS Handy Book . 4.
- Audels MECHANICAL Dictionary . 4.
- Audels AUTOMOBILE GUIDE . 4.
- Audels DIESEL ENGINE MANUAL . 2.
- Audels MARINE ENGINEERS Handy Book . 4.
- Audels SHIPFITTERS Handy Book . 1.
- Gueths MECHANICAL DRAWING COURSE . 1.
- Rogers DRAWING and DESIGN . 2.
- Audels MILLWRIGHTS and Mechanics Guide . 4.
- Audels CARPENTERS and Builders Guides (4 vols.) . 6.
- Audels PLUMBERS and Steamfitters Guides (4 vols.) . 6.
- Audels MASONS and Builders Guides (4 vols.) . 6.
- Master PAINTER and DECORATOR . 2.
- Audels GARDENERS & GROWERS GUIDES (4 vols.) . 6.
- Audels ENGINEERS and Mechanics Guides Nos. 1, 2, 3, 4, 5, 6, 7 and 8 complete . 12.
- Audels Answers on Practical ENGINEERING . 1.
- Hawkins Aids to ENGINEERS EXAMINATION . 2.
- Audels ELECTRICIANS EXAMINATIONS . 1.
- Audels WIRING DIAGRAMS . 1.
- Audels Handy Book of PRACTICAL ELECTRICITY . 4.
- Audels ELECTRICAL POWER CALCULATIONS . 2.
- Hawkins ELECTRICAL Guides at \$1. each . 10.
- Audels ELECTRONIC DEVICES . 2.
- Audels ELECTRIC Dictionary . 2.
- Audels RADIOMANS GUIDE . 4.
- Audels NEW ELECTRIC LIBRARY at \$1.50 a Volume Vols. I, II, III, IV, V, VI, VII, VIII, IX, X, XI, XII.

\_\_\_\_\_

Name \_\_\_\_\_

Address \_\_\_\_\_

Occupation \_\_\_\_\_

Employed by \_\_\_\_\_ RCF



## RADIO'S GOOD OLD DAYS

By RAYMOND KNIGHT

Last November the Institute of Radio Engineers held its first, the 1945 Radio Pioneers Party. Before an assembly of 1300 members of the I. R. E. Mr. Knight read this poem, accompanied on the piano by Ed East, well known radio entertainer.

When Crosby was only a crooner  
And not a corporation,  
When a program was simply a program  
And not an "operation."  
When Vallee had his adenoids  
And Ed Wynn was top buffoon  
And MacNamee sold Texaco  
By calling it "gasaloon."  
When the corn was green in the studios  
And the Amateur Hour the craze  
When Noble was making Life Savers  
*Them was the good old days!*

When Gernsback first startled the world  
Like a bolt from out of the blue,  
By predicting 100 things a month  
In the hopes that one would come true.  
When Tesla worked for Westinghouse  
And Steinmetz for GE  
Before Zworkin was workin' for RCA  
And they all worked for FTC.  
When Atwater Kent worked for a living  
And his scholarships were the craze  
When Western Electric MADE tele-  
phones  
*Them was the good old days!*

When the NBC chimes were rung by  
hand  
When there was still a J. P. Morgan  
Before Ed Armstrong was a steeplejack  
Before Hammond brought out his organ.  
When the Blue and the Red were  
Siamese Twins  
And were functioning unwitting  
That the FCC would later decide  
It was incest they were committing.  
Before Milton Cross went erudite  
And still called a vahze a vase  
When Jack Binns made the headlines  
*Them was the good old days!*

When Winchell was a columnist  
And not head of the FBI  
When NBC's Christmas parties  
Definitely were not dry.  
When Sarnoff was still a private  
Way before Philco went wild  
And started making radio sets  
And the other set makers got riled  
When Heatter was hotter than Hitler  
When Mark Woods got his first raise  
When a Net went berserk if you used  
the word "jerk"  
*Them was the good old days!*

When the F in FM meant frequency  
And the M meant modulation  
Before Petrillo decided FM  
Meant FORMULA to mock the nation.  
Before there were singing commercials  
To fill the air full of crap  
Before Bremmer got his Tully  
Before Eastman got his Clapp.  
When an S.O.S. was a C.Q.D.  
And a man said "Do you think you  
ought'a

## DON'T SETTLE FOR LESS THAN:

THE MOST

*Complete!*

There are three essentials to the successful operation of any radio repair shop: 1. Competent personnel; 2. Good test equipment; 3. Complete service data. All are of equal importance, so don't compromise with quality in your manuals, don't settle for less than the most complete source of authorized information. Remember, if you are called upon to service any and all models of radio receivers, only Rider Manuals can meet your needs.

Rider Manuals represent the only single source upon which you can depend for all the information you need on such vital material as receiver schematics, voltage data, alignment data, resistance values, chassis layouts and wiring, trimmer connections—in fact all the things that lead to quick diagnosis of troubles in ailing receivers.

—And they're complete! Since the publication of Volume I over 42,000 models have been covered—only Rider Manuals contain wiring diagrams on Scott receivers. (These diagrams were received officially from the E. H. Scott Radio Labs., Inc.)

So, see your jobber and place your order today to guarantee fastest possible delivery.



(See Prices Below)

### Get on the Mailing List for "Successful Servicing"

A monthly paper, dedicated to the financial and technical advancement of the electronic and radio maintenance man. Free distribution—Just

MAIL COUPON

JOHN F. RIDER PUBLISHER, INC.  
404 (e) FOURTH AVE., NEW YORK, N. Y.

NAME \_\_\_\_\_

ADDRESS \_\_\_\_\_

CITY \_\_\_\_\_

STATE \_\_\_\_\_

### YOU MUST STUDY TO KEEP UP TO DATE

Just Out "INSIDE THE VACUUM TUBE" . . . 424 Pages, \$4.50

#### RIDER MANUALS (14 VOLUMES)

Volumes XIV to VII . . .	\$12.50 each volume
Volume VI . . .	9.50 each volume
Abridged Manuals I to V (1 Vol.) . . .	\$15.00
Record Changers and Recorders . . .	7.50
The Cathode Ray Tube at Work . . .	4.00
Frequency Modulation . . .	2.00
Servicing by Signal Tracing . . .	4.00
The Meter at Work . . .	2.00

The Oscillator at Work . . .	\$2.50
Vacuum Tube Voltmeters . . .	2.50
Automatic Frequency Control Systems . . .	1.75
A-C Calculation Charts . . .	7.50

#### Hour-A-Day-with-Rider Series—

On "Alternating Currents in Radio Receivers"	
On "Resonance & Alignment"	
On "Automatic Volume Control"	
On "D-C Voltage Distribution"	1.25 each

JOHN F. RIDER PUBLISHER, INC. 404 Fourth Avenue, New York 16, N. Y.

Export Division: Rocke-International Electric Corp. 13 E. 40th Street New York City Cable: ARLAB

## RIDER MANUALS *are complete* IN 14 VOLUMES

Start out in that NC1 with a ham  
Like Harry Sadenwater?  
When the FCC was the FRC  
And television was only a phrase  
When radio was in its infancy  
*Them was the good old days!*

But when 1960 rolls around  
And we gather again to praise  
The achievements since 1945  
*THEY'LL be the good old days.*

Note: For those who do not go back to the old wireless days of 1908, the following explanations are in order: Ed Armstrong is Professor Edwin Armstrong of radio Superheterodyne and FM fame. The "steeplejack" refers to his FM tower at Alpine, N. J., which he climbed many times. Bremmer-Tully was a radio manufacturing firm, in business about 1910. Clapp Eastman was a famous radio manufacturing company building wireless transmitting transformers about 1909. The NC-1 was one of the airplanes

which took part in the Navy's famous flight across the Atlantic from which Harry Sadenwater sent the first airplane distress call on record when his plane was in trouble. Remember the NC-4? (Harry was recently elected president of the Radio Club of America.)

### HAM BANDS TO RE-OPEN

Amateur station licenses which were renewed November 15 will expire on April 15th next, the FCC reported last month. The bands on which operation is now permitted include the old ten- and five-meter bands, as well as one equivalent to the one formerly on 2.5 meters, the exact limits now being 28.0 to 29.7 mc., 56 to 60 mc., and 144 to 148 mc.

It is expected that several other amateur bands will be opened on April 15, if not earlier.



# RADIO-ELECTRONIC CIRCUITS

## B-SUPPLY REGULATOR

Every serviceman and experimenter has needed a well-regulated power supply. The circuit shown in the diagram has been used and found most satisfactory. It uses no special voltage regulator tubes but nevertheless provides practically unchanging voltage output regardless of varying load. Ripple voltage present in the output is less than two-tenths of one percent of the d.c. output voltage. Regulation of output voltage is better than one percent between no load and 70-ma load.

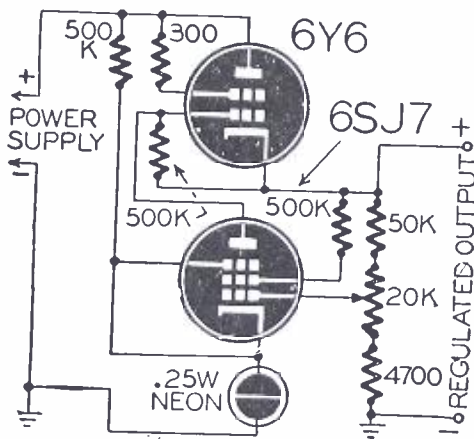

This circuit is ideal for use with oscillators and special circuits where good voltage regulation is required. All resistors used are of one-watt rating. The 20,000-ohm control is used to set the output voltage to any desired level.

HARRY TELLIS  
Bridgeport, Conn.

## SIGNAL GENERATOR

This circuit has been used with very good results. The 6C5 is used as an r.f. oscillator; the 6K8 is used as an a.f. oscillator and mixer. The r.f. oscillator is very stable and the frequency is not changed by switching the modulation on and off or by varying the output.

The coil L consists of 130 turns of No. 30 enamelled wire wound on a 1½-inch form tapped 30 turns from the bottom of the coil. The audio choke may be anything on hand; an audio transformer with the primary and secondary connected in series may be used. Any well-regulated power supply may be utilized. All grid and plate leads should be shielded. The set should be housed in a metal cabinet to prevent oscillation. The frequency range is from 750 to

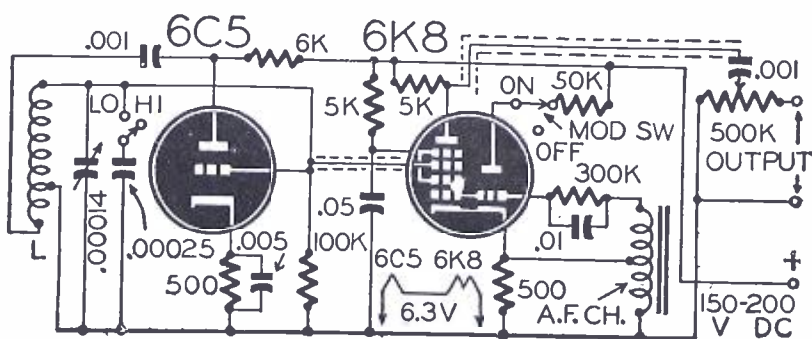

1350 kc and from 440 to 525 kc. The calibration may be accomplished easily with the aid of a good receiver that is known to be accurately aligned.

CPL. DALE COURTER  
Hamilton Field, Calif.

## FILTERLESS RADIO

I find that by connecting the screen of a pentode tube such as the 12A7 to the negative side of the circuit, a receiver can be constructed which will operate practically free from hum with a minimum of filter inductance and capacity. In the circuit shown in the diagram, only the phones and a 2-microfarad condenser constitute the total filtering capacity and inductance. Reception is practically hum-free. The circuit shown was pretuned to a local station, but a variable condenser can be put across the coil to tune in all stations.

Connection of the screen grid to negative is the essential feature of this circuit. If it is connected to the high-voltage supply or the plate, loud hum drowns out the signal.

This does not require a dual-purpose tube like the 12A7, 117N7, etc. The rectified a.c. from a 25Z5 can be connected to the phones and then through them to

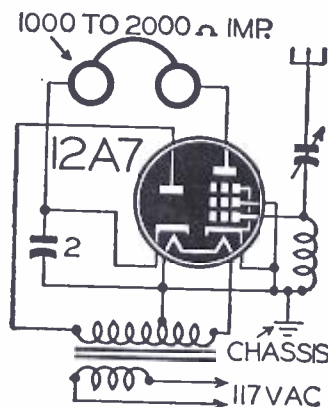

the plate of a 43. The 43 screen is tied to the cathode and a 2 µf condenser connected across the output of the 25Z5. More capacity can be used, but less will cause an increase in the hum.

L. E. SHEPARD,  
Toledo, Ohio

## ONE-TUBE RECEIVER

This one-tube regenerative circuit gives excellent results on the broadcast band. I receive five to ten stations at fair loudspeaker volume with a 60-foot antenna and a good ground. Local stations can be received with a short 10-foot piece of wire strung around the room or laid on the floor.

The tube is a 1D8GT — a combination diode-triode-pentode in one envelope. The diode is unused and is

grounded. The coil is a regular antenna coil with 30 turns of No. 30 wire wound on it for a tickler. Regeneration is controlled by a 50,000-ohm variable resistor across the tickler.

RICHARD KRAFT, JR.  
Crown Point, Indiana

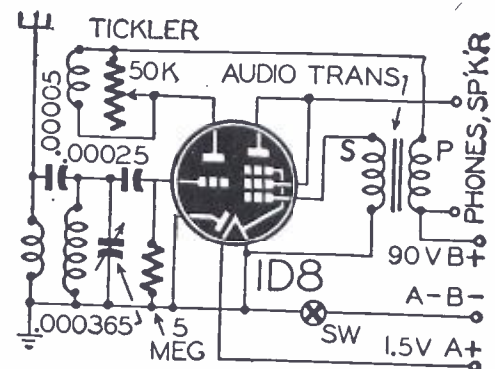

## DUAL CIRCUIT

Recently I needed a simple one-tube signal generator which would cover the broadcast band with fair stability. I finally tried an electron-coupled oscillator circuit using a 6SQ7 tube (the triode section), and I got what I wanted. I also got a bigger surprise!

I connected an aerial wire to the grid end of the tank coil and grounded the chassis. Then I connected a pair of headphones in the plate circuit. I immediately picked up a good half-dozen strong stations. The louder ones were of sufficient volume to be uncomfortable, making a control necessary.

The nearest station to me is a 5000-watter located several hundred miles away. I received a number even farther away.

The tank circuit size depends on the condenser used. With one of 350 µmf, use about 100 turns tapped 20 turns from the bottom. The coil is wound with No. 30 enamelled wire on a 1½-inch form.

To use as a signal generator, take off the aerial and ground, disconnect phones, and short the jack (or use a closed-circuit jack). The regeneration control may be used in place of an attenuator.

BENNIE JOHNSON  
Huron, South Dakota

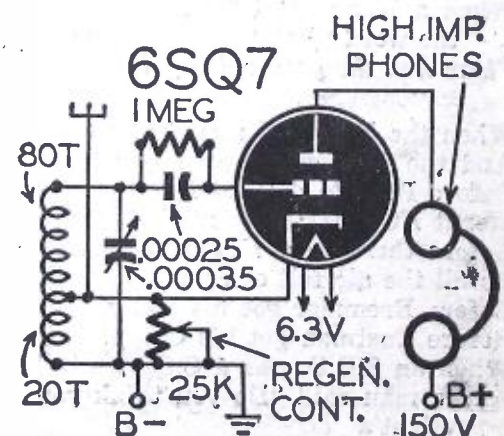



**HI-FI TRF TUNER**  
(Continued from page 401)

high end is spotted. After all this is done, it should be gone over and finally repeaked. The complete tuner is built on a chassis 7x7x2-inches and a general layout can be seen from the photos. The entire unit is housed in a sheet metal cabinet 9x9x6-inches.

The amplifier used in connection with this tuner furnished plate and heater power. The amplifier should be a high quality job and the speaker system one that will properly reproduce the combination's output. The amplifier actually used was a 6J5, a 6N7 phase inverter, a pair of 6L6G's in Class A. A tone-switching setup provided a 12-db boost and either end or both ends of the audio range (See September, 1942 *Electronics*, page 63, "Audio Frequency Compensating Circuits").

The speaker setup consisted of a 15-inch Von-Dee and two RCA accordion-edge speakers, all on an infinite baffle, properly phased and with a crossover network at 400 cycles. The Von-Dee speaker referred to is a special high-quality speaker capable of remarkable range and is manufactured by Stephens Manufacturing Co..

The quality of this tuner-amplifier combination is entirely satisfactory, even to the critical ear of a musician. Several people, in fact many, when this combination was in operation have said, "You certainly can tell the difference between FM and standard broadcast, can't you?"

**PHOTO OF ATOM BURSTS**

When, in 1939, scientists first sent slow neutrons into the heart of the uranium atom, enormous voltages were created. These show up as vertical lines on the screen of a cathode-ray tube used in a device to measure voltages. The upright lines indicate potentials of more than 200,000,000 volts. These giant spurts of power revealed the possibilities of atomic fission and started research which ended with the atomic bomb, that energy package which surpasses in power anything hitherto seen on earth.

Not alone in discovery of the principles of atomic energy did electronic apparatus play an important part—various types of electronic apparatus were used throughout the complicated stages of processing and purifying U-235.

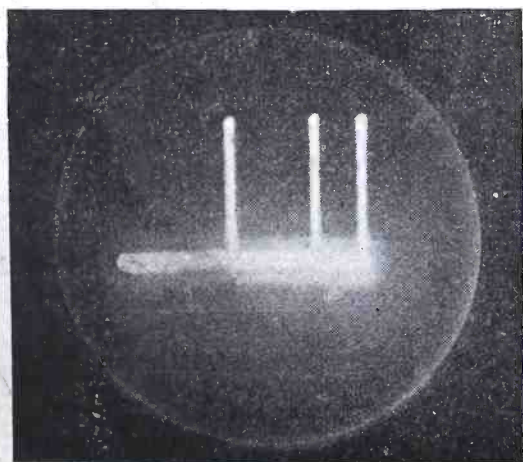

**HOW TO PASS Commercial Radio Operators' FCC LICENSE EXAMINATIONS...**

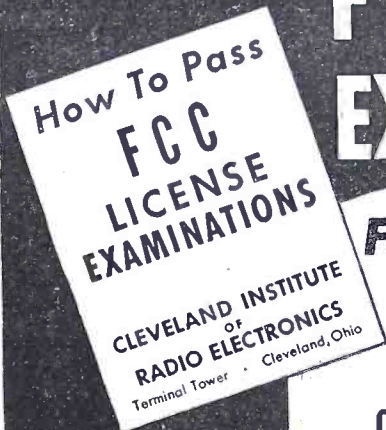

**FREE BOOKLET** Tells you the Government Requirements for all classes of commercial licenses. Saves you many hours of random, undirected study. Assures a minimum of time in getting your ticket!

**CLEVELAND INSTITUTE OF RADIO ELECTRONICS**

Successors to Nilson Radio School, founded 1939; Smith Practical Radio Institute, founded 1934

RC-3 TERMINAL TOWER

CLEVELAND 13, OHIO

MAIL THIS COUPON

**Don't Delay—Write Today!**

CLEVELAND INSTITUTE OF RADIO ELECTRONICS  
RC-3 Terminal Tower, Cleveland 13, Ohio

Gentlemen: Please send your FREE Booklet, "How to Pass FCC License Examinations."

Name .....

Address .....

City ..... Zone..... State.....

**HAM HEADQUARTERS FOR Equipment and Information**

**EXTRA SPECIALS**

- 24 G Tubes Limited Supply \$1.90 net
- Leach Relay Low Loss D.P.D.T. 6V. D. C. Coil \$1.75
- Pyrex Feed Through Insulator with 2" Mounting Ring.....69c net
- Ceramic Caps for 866s and 807s.....19c net

Mail Orders Promptly Filled  
Amateurs to Serve You

Write Dept. RC  
W6SCQ--W8WLG/6--W6NAT  
W6SSU

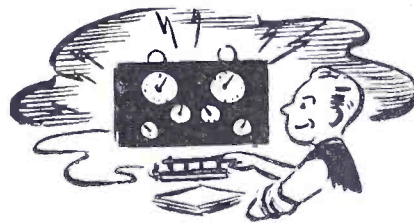

**FOR YOUR NEW RIG**

Monitor Crystals 7 MC. Band Type 43B.....\$2.85 net

Also complete Line of:  
NATIONAL EIMAC  
JOHNSON JONES  
OHMITE AMPREX  
TAYLOR ADVANCE  
BARKER-WILLIAMSON  
HALLICRAFTERS

**Radio Product Sales Company**

238 WEST 15TH STREET  
LOS ANGELES 15, CALIFORNIA PRospect 7471



# RADIO-ELECTRONIC DEVICES

## INPUT TRANSFORMERS

The Langevin Co., Inc.  
New York, N. Y.

These transformers are intended for high-quality amplifier requirements. The 400 series is designed to occupy minimum space with excellent frequency response. They combine a high permeability shield with rotatable strap mounting for minimum stray field pickup. Equipped with 10-inch color-coded leads.

These transformers are of three types:

401-A Input Transformer operating from 30-250-600 ohms primary to 30,000 ohms secondary center-tapped.

Type 4001C Bridging Input Transformer with a nominal impedance 600-15,000 ohms to 60,000 ohms secondary. With proper input circuits, input impedance range 0-25,000 ohms.



The third type is a 402-A Input Transformer with a nominal 30-120 ohms primary to 50,000 ohms secondary. Input impedance range 0-250 ohms.

All types have a maximum operating level + 10 v.u. at .001 milliwatt reference level.

Finish is baked gray enamel. 2-inch to center mounting, 1½-inch outside diameter x 2¼ inches high.—Radio-Craft

## RECORD CHANGER

Farnsworth Television and Radio Corp.  
Fort Wayne, Indiana

The new 1946 P-50 Automatic Record Changer employs three shelves, instead of the usual one or two shelves, which reduces chipping and enlarging the record's center hole to a minimum.



Other important features of this record changer are: convenience of installation because of the top-side type of mounting; non-removable spindle, which permits easier loading and unloading of records; single finger-tip control knob, which includes off-on, manual, reject and automatic positions.

The light weight tone arm has a one-ounce needle pressure and will take any standard pickup cartridge. The turntable rotates on ball thrust bearings which insure minimum variation of speed with a changing load of records.—Radio-Craft

## VTVM MULTITESTER

Precision Apparatus Co.  
Elmhurst, N. Y.

The EV-10-P is a new portable, vacuum tube multi-range tested with all zero-center vacuum tube voltmeter ranges, and also includes direct reading megohmmeter, milliammeter, ammeter, output and decibel meter plus standard sensitivity 1000 ohms-per-volt a.c.-d.c. voltmeter ranges.

Incorporating a full 7-inch rectangular meter, it employs a stabilized bridge circuit using three tubes, a 6C5, 6X5 and VR-150. The power supply plate voltage output remains constant over severe line voltage variations, eliminating annoying meter vs. line-voltage

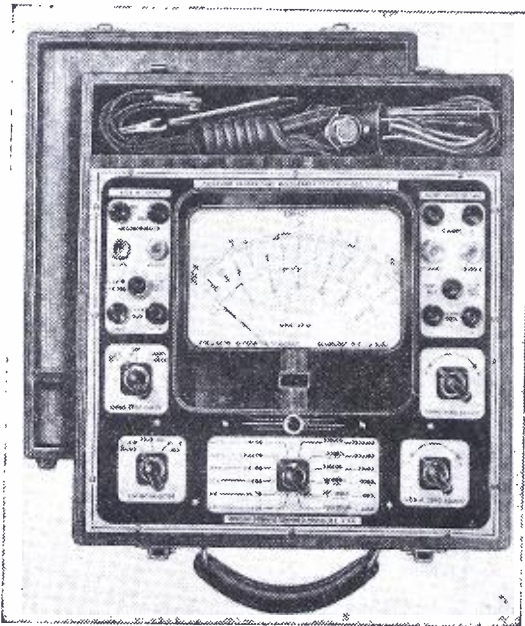

shift. The meter is zero-center on all ranges when used in the VTVM circuit, indicating both polarity and magnitude without reversing the prods or use of a polarity switch.

The functions are as follows: Eight zero-center VTVM ranges from  $\pm 3$  volts d.c. to  $\pm 6000$  volts d.c. full scale; six resistance ranges from 0-2000 ohms to 0-2000 megohms; eight a.c. and eight d.c. current ranges from 600 microamps to 12 amperes; eight output ranges from 3 to 6000 volts and eight decibel ranges from -26 to +70 db. These ranges cover nearly all requirements in present and future electronics fields.—Radio-Craft

## SOUND PROJECTOR

University Laboratories  
New York, N. Y.

The Model RBP-12 illustrated and a smaller RBP-8 are infinite baffle housings for cone type loud-speakers and are designed for high quality reproduction of music and speech. Their infinite baffle design provides excellent low-frequency response. Both speakers are rubber-rim damped to eliminate mechanical resonance. Types RBP-12 and RBP-8 are engineered for 360° sound dispersion and incorporate construction features that reduce undue sound concentration directly beneath the speaker.

Data—Model RBP-12:

Dispersion—360°.

Frequency—Down to 50 cycles.

Diameter—27 inches.

Height—11 inches.

Weight—19 pounds.

Designed for use with any standard 12-inch Cone Speaker.—Radio-Craft

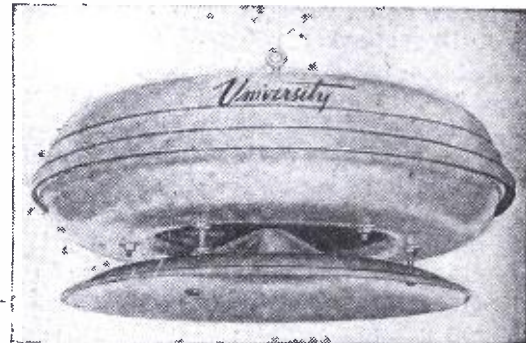

## RAILROAD LOUD-SPEAKER

Operadio Manufacturing Co.  
St. Charles, Illinois

This railroad-type loud-speaker is engineered to produce a maximum of voice identification, intelligibility and volume. In addition, it is specially designed to withstand dirt, wind and water. For railroad traffic control or intercommunication, the loud-speaker is completely adaptable for mounting on locomotive exteriors, within locomotive cabs, in a caboose or in switchyards.—Radio-Craft





## ANTI RADAR EQUIPMENT

(Continued from page 390)

have important applications in peace is the Loran system of locating a ship. This is superior to straight direction finding, as the ship operator can get his position exactly without having to communicate with the shore stations. Radar may be the most important peace-time aid to navigation, as it permits entry into crowded harbors at night or in dense fog with little more danger than in bright daylight. Even railroads are seriously considering the use of radar as a means of preventing rear-end collisions.

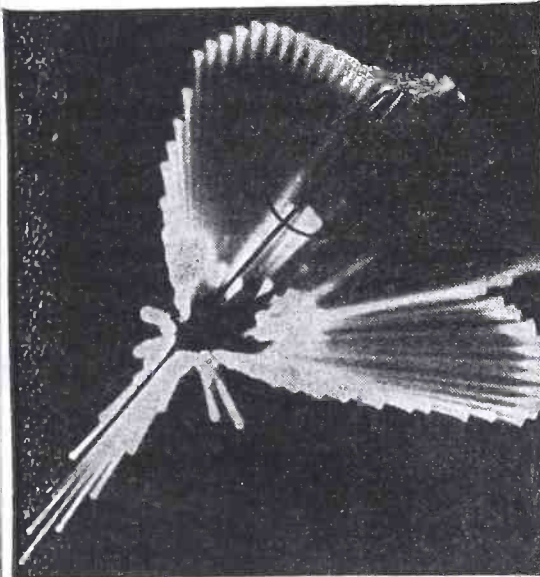
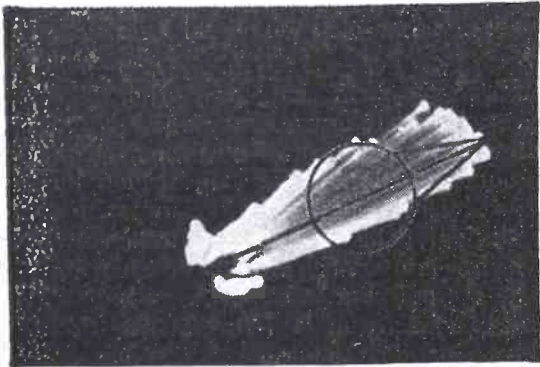

Photo C, above—One signal being received.  
Photo D, below—Pattern for several signals.

The greatest problem, however, has been development of transmitters capable of putting out considerable power at microwave frequencies. It will be remembered that during the discussions on high-definition television which took place last year one of the chief objections was that it might take years to develop the transmitters required for the high frequencies involved. The equipment described here and pictured on the cover should be the answer to that problem. Not alone in television will such apparatus be useful—there are many applications in sound broadcasting and continuous wave or pulse telegraphy to which it is particularly adapted.

Broadcast stations in the United States have now passed the thousand mark, the FCC reported at the end of last year. When normal licensing was resumed on October 8, the number was 961; on December 14 it reached 1,001.

## G-E TUBE CHECKER

Quick, easy, accurate tube checking which saves you time and trouble and keeps your customers happy—that's the job the TC-3P is built to do. Line Voltage and tube quality, or shorts, may all be checked on one selector switch. Individually operated switches permit placing the proper voltage on the proper pin of the tube. The G-E Tube Checker is available in either the Portable (TC-3P) or Counter Model (TC-3). Write: Specialty Division, Electronics Department, General Electric Company, Syracuse, New York.

**GENERAL ELECTRIC**

177-D1

Electronic Measuring  
Instruments

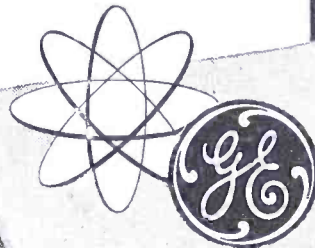
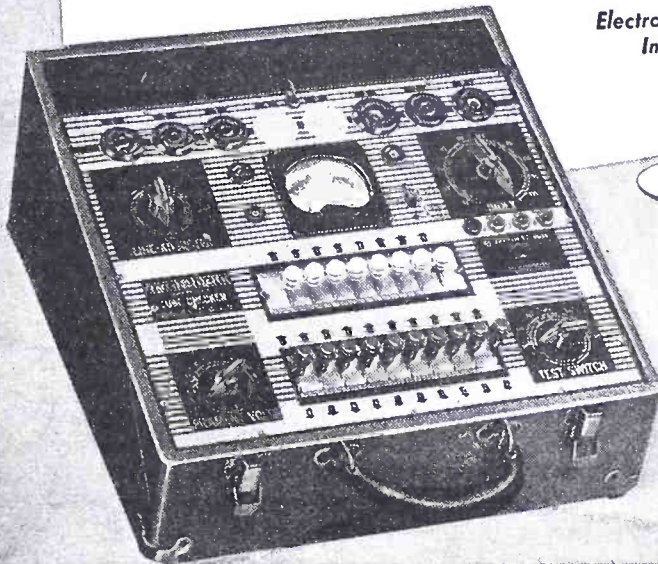

**TC-3P**

## SPEED UP REPAIRS WITH THESE G-C AIDS!

Handle Dial Belt Replacements the Easy G-C Way!



1. To determine proper belt for any radio, G-C supplies a complete Belt Replacement Guide and Measuring Scale.



2. By using G-C Belt Guide, just check model number of the set to determine correct G-C Belt.



3. If you don't know model number or make of the set, use G-C Measuring Scale and simple instructions to measure belt.



4. Order belt by number from your radio parts distributor. Phone or mail your order to receive prompt service—no waiting.



5. Better still—have a complete G-C Belt Kit on hand. Belts are indexed in permanent steel box with slide-in drawer.

**FREE TO ALL RADIO SERVICEMEN**—68 page G-C No. 345 Belt Guide and Service Book and Measuring Scale. Ask for them at your Radio Parts Distributor.

Get "Smooth-Strong-Correct Fit" G-C Dial Belts  
from Your Radio Parts Distributor



**GENERAL CEMENT MFG. CO.**  
ROCKFORD, ILLINOIS

## RADIOSONDES \$1

Miniature H-F transmitters with temperature, humidity and barometric elements. Used for radio weather reporting. Gov't surplus, as is. An unequalled bargain for parts. Limited quantity. Send your dollar bill to:  
**W. H. DEACY, 231 E 76, New York 21**

Postpaid

## RADIO SERVICEMEN AND HAMS!

Complete stocks of parts, tubes, test equipment available from Hudson Valley's only distributor. What do you need? Kit 25 By-pass Cond. All 600 v. \$1.75

**CHIEF ELECTRONICS**

224 MAIN ST.

POUGHKEEPSIE, N. Y.



# TRY THIS ONE!

## TUBE SUBSTITUTION

This is a simple way for substituting a 5T4, 5W4, or 5Y3 for an 80 without changing the four-prong socket or making an adapter plug. I discovered that prongs 2, 4, 6, and 8 on an octal tube line up almost perfectly with pins 1, 2, 3, 4 on a four-prong tube. Therefore if the elements in a four- and eight-prong tube were identical and if the leads from them were connected to the corresponding prongs mentioned, then after changing the sizes of the octal tube prongs, the eight-prong tube could be substituted for the four-prong tube.

All of these requirements are met in substituting a 5Y3 for an 80. Prongs 1, 3, 5, and 7 on the octal tube are cut off close to the base of the tube. The large prongs from an old four-prong tube are cut off and soldered over pins 2 and 8 on the octal tube. The two smaller prongs are then soldered over pins 4 and 6. This makes a neat job that will plug right into a four-prong socket once the locator key is removed.

If more current is required from a power pack than the original 80 can deliver, the 5T4 may be used in place of the 80.

DAVE STOUT,  
Santa Barbara, Calif.

## SIGNAL GENERATOR

A good audio signal may be obtained by using an amplifier and an audio transformer. By connecting the secondary leads of the transformer to the input of the amplifier and the primary leads in series with the output circuit, you will have a condition of feedback.

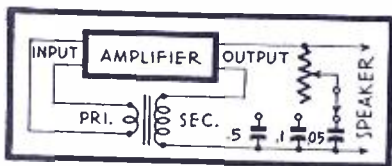

The tone control is optional because it need only be used where an adjustable audio frequency is desired.

Improvements on tone and quality may be made by a few circuit changes or variations. If, after this has been hooked up according to the diagram, no response is heard, reverse the input leads.

LEON POLLARD,  
Dorchester, Mass.

## HEADPHONE SOCKET

The small sockets used on 45-volt hearing-aid batteries make an excellent emergency substitution for phone jacks. The sockets are easy to remove by cutting the cardboard portion covering the plug away, and snipping the leads. The holes where the rivets originally were

are used for mounting. Connections to the phones can be made to the original soldering lugs on the battery socket.

ROBERT J. CUTA,  
La Crosse, Wis.

Radio-Craft wants original kinks from its readers, and will award a seven-month subscription for each one published. To be accepted, ideas must be new and useful. Send your pet shortcut or new idea in today!

## U. H. F. ANTENNA

For use on 2½ meters, a novel antenna constructed from two steel tape rules of the self-supporting type makes a highly efficient system and is extremely portable.

The steel rules are drilled, tapped and bolted to a supporting strip of polystyrene 4 x ½ x ¼. The polystyrene

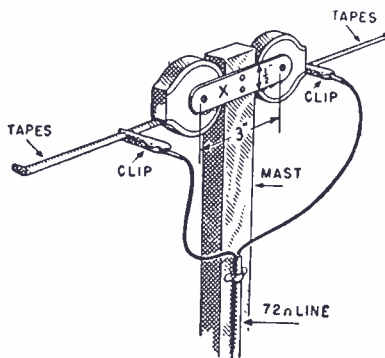

strip is marked "X" in the diagram. Only one of these need be used. The center of the supporting insulator is fixed to the supporting mast. The aerial is fed by a 72-ohm line with alligator clips on its ends. By adjusting the clips and the length of the tapes, the aerial may be loaded to suit the frequency being used.

W. DUGGAN, JR.,  
Goshen, N. Y.

## TEST-PROD TIPS

After having had several experiences of having test leads break off at the point of greatest strain (the edge of the cord tip), I figured out a kink which proved very satisfactory.

The cord tip is first bent at right angles and another tip is soldered on to allow insertion into a standard instrument jack. A piece of spaghetti is then slipped over the tips to prevent accidental contact with the tip itself.

JOE LATHAM,  
Ontario, Calif.

## NEW TUBES, OLD SET

The older receivers using 2.5-volt tubes can be modernized by completely converting to 6.3-volt tubes. In some cases where a replacement tube with a 2.5-volt heater is not available, a 6.3 volt one can be used without the expense and inconvenience of installing a new power transformer. The basic change neces-

sary is the replacement of the 80 with a 6X5-GT or similar rectifier. The 5-volt winding is added to half of the 2.5-volt winding as shown in the diagram, to obtain 6.25 volts. The allowable current is limited by the rating of the 5-volt wind-

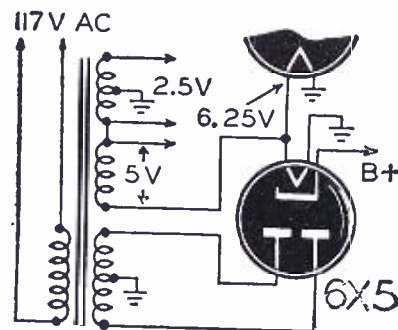

ing which is usually 2 amps. If 3.75 volts is obtained instead of 6.25 volts, the connection from the 5-volt winding should be made to the opposite lead of the 2.5-volt winding.

Y. MUKAI,  
Seattle, Wash.

## A.C. METER ADAPTER

The serviceman who wishes to measure a.c. amperes occasionally but has no a.c. ammeter can build the gadget shown to be used in connection with an a.c. voltmeter. This one was made to be used with a Triplet 400-ohm, moving-vane type meter, with a 10-volt

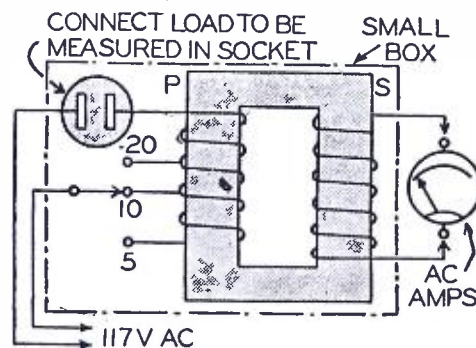

scale. It was mounted in a small box with a panel about 4 x 6 inches.

The device consists of a current transformer made from an old output transformer, a fairly heavy tap-switch, a convenience outlet, a short cord equipped with phone tips, and a 3-foot cord with plug.

The voice-coil winding of an output transformer is removed and 15 turns of No. 12 wire is wound on in its place. This winding must be heavy enough to carry the maximum amperage to be measured.

I used another a.c. ammeter to calibrate mine and made the first tap on the winding where five amperes load gave full-scale reading on the voltmeter. The second tap was made to give full-scale reading at ten amperes, and the third tap was made to give full-scale reading at twenty amperes.

E. C. WARREN,  
Flint, Mich.



## Radio Thirty-Five Years Ago

In Gernsback Publications

**HUGO GERNSBACK**

Founder

Modern Electrics .....	1908
Electrical Experimenter .....	1913
Radio News .....	1919
Science & Invention .....	1920
Radio-Craft .....	1929
Short-Wave Craft .....	1930
Wireless Association of America .....	1908

Some of the larger libraries in the country still have copies of Modern Electrics on file for interested readers.

**FROM** the March, 1911, issue of **MODERN ELECTRICS:**

- Wireless for Moving Trains.
- Cathode Ray Tele-Photography, by Dr. Alfred Gradenwitz.
- A New Photophone.
- An Ingenious Radiophonic Spark Gap.
- Improved Oscillograph.
- A New Spark Gap.
- Improved Transmitting Hook-Up, by A. C. Marlowe.
- A Distress Message at Sea, by Arch Macdonald.
- A Handy Detector.
- How to Make an Independent Inter-rupter.
- Fixed Receiving Condenser.
- Tuning Coil Attachment.
- Aerial Switch.
- Air-Cooled Spark Gap.
- A Sending Condenser.
- A Good Spark Gap.
- A Very Good Lead-in.
- A Wireless Key.
- New Idea Aerial.
- A Unique Receiving Outfit.

### RURALISTS NOT SERVED?

**A**GRICULTURAL audiences are not served as completely by radio broadcasters as their importance would warrant, reported Dr. M. L. Wilson, director of extension work, Department of Agriculture, testifying before the clear-channel hearings held by the FCC.

He testified that "far too often" agents of the extension service have started farm programs and established audiences "only to find suddenly that the time has been sold for another program or moved to some much less satisfactory hour for working farm people."

"Almost none of our agents," he continued, "have programs in the choice evening hours, when farmers as well as city people can best listen. Very few have access to farm service time at the satisfactory noon hour on the clear channel or higher-powered, supposedly rural coverage stations."

Dr. Wilson recommended that the FCC allocate licenses in such a way as to "require stations with adequate power and suitable time to reach all farmers with a fairly complete flow of locally usable information, in the local as well as the general or clear channel field."

He further recommended that the FCC adopt rules or policies to require that broadcasters provide suitable and dependable time for farm service programs, both clear-channel and local stations.

# Radio Parts

## IMMEDIATE SHIPMENT!

## Electronic Equipment

**Mail Coupon Below for New CONCORD CATALOG—FREE!**

32 pages of money-saving bargains in hundreds of standard-line, top-quality radio and electronic parts. Note these typical CONCORD values—



**OHMITE Model G POTENTIOMETER**

15 Ohms, 75 Watts, \$1.95  
1/4" diam. shaft. 5B2075.



**Time Delay Relay**

15 Amp. contacts, timed at 60 sec. + or - 3 sec. for 115 V.  
60c operation.  
5B4097 ..... \$4.95



**PRECISION RESISTOR**

12 megohm, 10 K. V. Sprague ferrule mounting type  
5B121 ..... \$4.95



**VACUUM CAPACITOR**

12 mmfd., 20,000 volts. Overall size: 6 1/2" x 2 1/4".  
5B3169 ..... \$3.95



**ORDER TODAY for shipment tomorrow from CONCORD**

Huge stocks in TWO convenient warehouses—one in CHICAGO and one in ATLANTA—are ready NOW to make IMMEDIATE SHIPMENT of radio and electronic parts and equipment of dependable, nationally-known quality—and at Victory Clearance prices that mean important savings on Meters, Condensers, Transformers, Resistors, Controls, Switches, Relays, Test Equipment, Generators, Microphones, Tools, and hundreds of Repair, Replacement and Accessory Parts. Whatever your needs, see the surprising values offered in CONCORD'S New Catalog. Mail the coupon for your FREE copy now.

**CONCORD RADIO CORPORATION**  
*Lafayette Radio Corporation*

CHICAGO 7, ILL. ATLANTA 3, GA.  
901 W. Jackson Blvd. 265 Peachtree Street

CONCORD RADIO CORPORATION  
901 W. Jackson Blvd.  
Dept. RC-36, Chicago 7, Ill.  
Please RUSH FREE copy of CONCORD'S new 32-page CATALOG.

Name .....

Address .....

City ..... State .....









## "VIDEOSONIC" SYSTEM

(Continued from page 385)

is that it eliminates mutual interference between the sound and vision programs. In pre-war television receivers it was necessary to separate by means of filters, the sound and vision programs and route them to their respective receivers. Due to the limitation of the filters this separation was not always good enough, particularly under strong signal conditions, and a certain amount of interference between the sound and vision programs was noticeable.

In cases where common amplifier stages were used for sound and vision this was particularly troublesome as, unless the amplifier circuits had a very linear characteristic, characteristic sound and vision inter-modulation products were produced. These troubles disappear when the separate sound channel is dispensed with. The amplitude of the sound pulses contain no modulation products and, therefore, will be constant in the absence of fading. This forms a convenient reference level for the development of a.v.c. voltages for the vision amplifier.

Other advantages are that less frequency space is required for television transmissions, and this, in turn, means that the receiving antenna need only cover the vision band of frequencies, resulting in a slight increase in efficiency. The problems of transmitting antenna design are relieved particularly when horizontal polarization is employed because coupling between the sound and vision antennas need no longer be considered when the sound is transmitted as an integral part of the vision waveform.

The Videosonic system could readily be applied to the negative waveforms current in America by transmitting sound pulses having an amplitude greater than the line synchronizing pulse during the line synchronizing period. Synchronization of the line oscillators would be effected by a leading edge of the pulse occurring at regular intervals of time, according to current practice. In this case line blanking would be unnecessary, and, moreover, a 30-frame 525-line system would allow of the reproduction of audio frequencies up to 7.5 kc.

With regard to the future possibilities of the system the audio fidelity will, of course, increase with the definition of the television system. It should be possible to transmit two sound channels with high definition picture. The reason for this is not immediately apparent as it would seem that the time space available for the sound pulse within the line synchronizing pulse would shrink if the number of lines transmitted per second was increased. In fact the space available for the sound pulse would be proportional to  $1/n$  where it is the number of lines transmitted per second. If the frame repetition rate is maintained constant the number of lines per frame will be proportional to  $n$  and the time duration of the narrowest sound pulse which can be transmitted will be proportional to  $1/n^2$ , provided that equivalent horizontal and vertical definition is maintained. Thus, although the space available for sound transmission shrinks with increasing definition, the space occupied by the pulse shrinks at an even greater rate. Use of this fact may possibly be in the transmission of stereophonic sound.

Variations in the height of the pulses could be used to convey switching information to the receiver. The a.v.c. requirements already mentioned do not demand that every pulse should have the same height but merely that the

(Continued on following page)

# Electricity

Models range from 350 to 35,000 watts, A. C. types from 115 to 660 volts, 50, 60, 180 cycles, single or three-phase and 400, 500 and 800 cycles, single phase. D. C. types from 6 to 4000 volts. Also available in dual voltage and special frequency types.

Onan

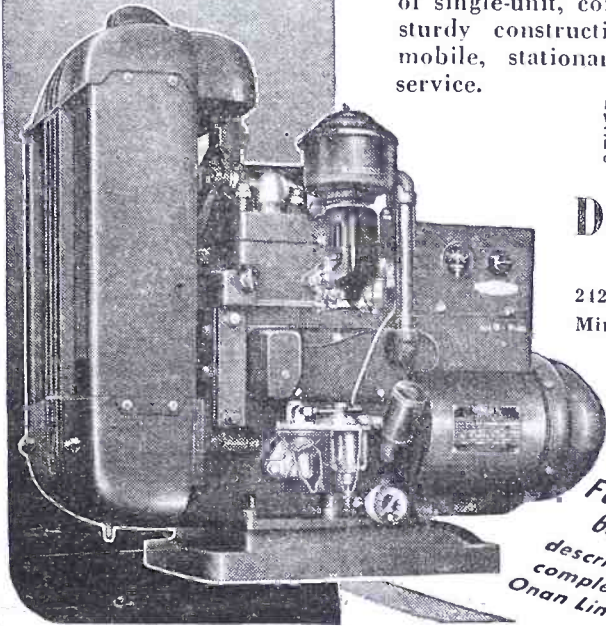

## FOR RADIO AND ELECTRONIC APPLICATIONS

ONAN ELECTRIC GENERATING PLANTS supply reliable, economical electrical service for electronics and television applications as well as for scores of general uses. Driven by Onan-built, 4-cycle gasoline engines, these power units are of single-unit, compact design and sturdy construction. Suitable for mobile, stationary or emergency service.

Model shown is from W2C series; 2000 to 3500 watts; powered by Onan-built, two-cylinder, water-cooled engine.

**D. W. ONAN**  
AND SONS

2125 Royalston Avenue  
Minneapolis 5 Minn.

Write  
For Folder  
690-A  
describing  
complete  
Onan Line

# WALSCO

## PRODUCTS

help the radioman

### WALSCO FIRST To Bring Out A LOW PRICED FLOCK



### FINISHING KIT WITH NEW FLOCK SPRAY GUN

Includes 2 colors of Flock,  
Undercoats, Thinner, Brush,  
Instructions

Dealer's Net Price \$6.45  
For Complete Outfit

Also available, a complete line of Flock Finishing  
Materials. Write Dept. RC for details.

## WALTER L. SCHOTT CO.

BEVERLY HILLS, CALIFORNIA • CHICAGO 5, ILLINOIS

Make your own <sup>8 m/m • 16 m/m</sup> **Talkies**  
WITH PAT'D. **FILMGRAPH** RECORDER  
and Instantaneous Permanent  
PLAYBACK UNIT. Lengthy Recordings;  
Clear, Powerful; Eliminates Titles.  
CIRCULAR FREE  
MILES REPRODUCER CO., INC. 812 BROADWAY, N.Y.3 RC-3

FILTER CONDENSER BARGAINS!  
BIG NEW CATALOG! WRITE FOR LIST!

CHICAGO  
**Newark ELECTRIC Company**

115-117 W. 45th St. NEW YORK 19 323 W. Madison St. CHICAGO 6



# Every TECHNICIAN NEEDS THIS ALL-PURPOSE SOLDERING PENCIL

No. 537 Pencil  
Tip made from  
Elkaloy A Tip  
1/8 dia.

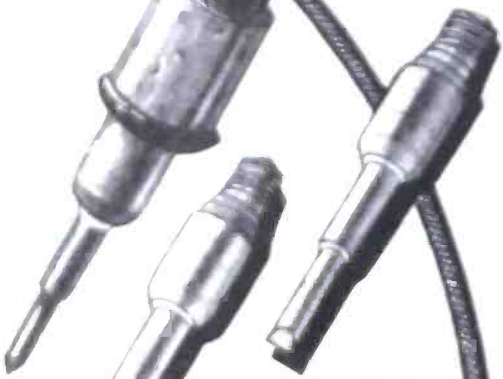

No. 536  
Standard  
Tip, made from  
Hard Drawn  
Copper



No. 538 Chisel  
Tip, made from  
Elkaloy A, Tip  
1/8 dia.

No. 539  
Extra Hot,  
made from  
Elkaloy A

A ruggedly built soldering tool for speedy precision on intricate hard-to-reach jobs. Takes plenty of punishment... weighs only 3.6 ounces... perfectly balanced, length, 7 inches... heats in 90 seconds... draws only 17 watts and handles with fountain pen ease. Unit complete with any one tip sells for less than \$2. Order from your nearest Electronics Distributor.

**Ungar**  
Electric Tools, Inc.  
Formerly Harry A. Ungar, Inc.  
LOS ANGELES 54, CALIF.

## "VIDEOSONIC" SOUND

(Continued from previous page)

pulses should return to the same height gradually to maintain the a.v.c. voltage. The pulse height could readily be used to provide color synchronization in color television systems. The height of any particular pulse could determine the color of the next scanning line. Alternatively, whole frames could be scanned, each color, the sound pulse height during the field determining the color effect even more generally, the color scanning could be carried out by scanning a number of lines in one color at a time, color "weighting" being determined by the number of lines scanned in each color. In this case the color sequence would be unsynchronized with the frame repetition frequency.

The application of sound to the vision waveform does mean that a considerable saving can be made in the cost of television receivers, and it offers attractive advantages when applied to present day transmissions. The present restriction to a 5 kc audio channel will disappear as the definition is increased and the system will open up new fields for future development.

D. J. Lawson, M.Sc., is an Associate member of Britain's Institution of Electrical Engineers Associate Institute. Has undertaken extensive research on X-ray crystallography. Lectures on physics and telecommunications at the Woolwich Polytechnic (London). During World War II he led Britain's research team on A.A. shell, the radio proximity fuse.

## SUPER-REFLEX RADIO

(Continued from page 403)

shaft is cut in half and the two coils mounted at right angles and as far apart as practicable in a can 3 to 3½ inches high. Obviously they may be mounted in separate cans.

In the first i.f. transformer the coils are parallel, i.e., they are inductively coupled. In the second, the coils are capacity coupled through condenser C13. Hence, when separated it may be impossible to tune them down to 456 kc. Accordingly, a few turns of suitable wire may have to be added to each of these replacement windings.

The iron-core audio choke, L6, requires an inductance sufficiently large to block audio frequencies. It must have a low d.c. resistance—400 to 600 ohms. Its inductance can be anything from 10 to 15 henries. If you have or can obtain a medium size core, a suitable choke can be made up by winding on about 2200 turns of No. 36 or No. 38 enamel wire. The windings should be placed on in smooth even layers with thin wax paper between layers.

The speaker can be of the PM type, from 3½ to 6 inches, and the output transformer, L7, must be such as will

match the impedance of the output tube and, in addition, the voice coil of the speaker. A universal transformer of suitable design may be used. A dynamic speaker may be used instead of the PM. In this case the field coil will be used to filter the B supply, replacing resistor R10.

Now consider the tubes. The 6A8 is the converter. The 7E7 serves four distinct purposes: 1—It is the i.f. amplifier, and in that role we want it to be the most efficient, hence the low d.c. resistance of L6 and the high screen voltage on this tube. 2—It is the diode detector (prong 3). 3—It provides the a.v.c. (prongs 3 and 4). 4—Finally, it is the first audio amplifier. The cathodes of these two tubes go directly to ground. Negative bias for them is provided in an efficient, inexpensive and novel way. A negative voltage is developed at the oscillator grid (prong 5) of the 6A8 tube, which is dropped to approximate correct value by the resistors R1 and R3. Resistor R3 must be installed close to prong 5 and the other end connected to the a.v.c. circuit. Additional negative bias is provided by the a.v.c. as required.

The "Triad Super" performs as well as the average 5-tube radio. Its three tubes make it a very compact set. The dial mechanism is home-constructed.

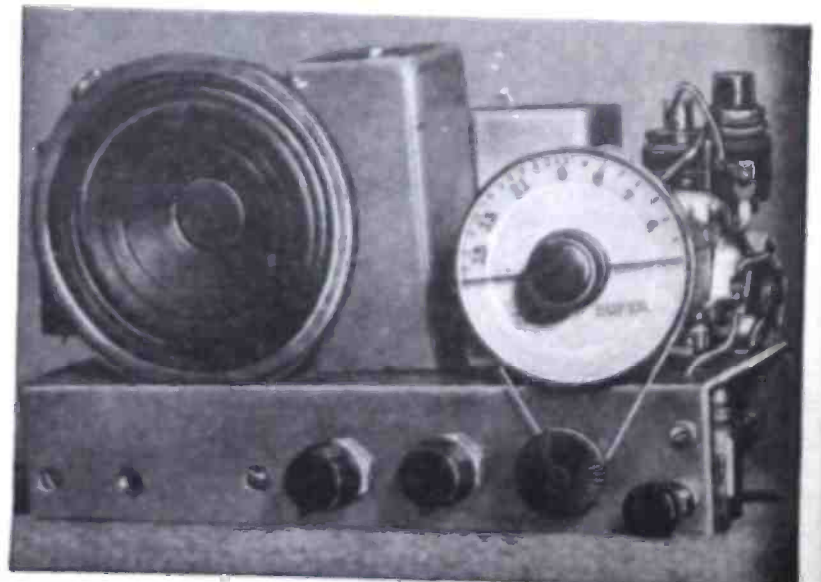



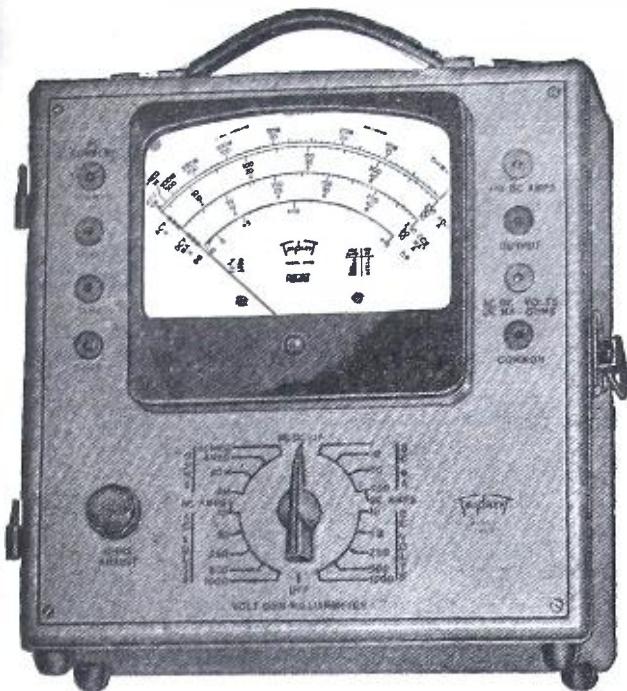

# MODEL 2405 Volt-Ohm-Milliammeter

25,000 OHMS PER VOLT D.C.



## SPECIFICATIONS

NEW "SQUARE LINE" metal case, attractive tan "hammered" baked-on enamel, brown trim.

■ **PLUG-IN RECTIFIER**—replacement in case of overloading is as simple as changing radio tube.

■ **READABILITY**—the most readable of all Volt-Ohm-Milliammeter scales—5.6 inches long at top arc.

■ **RED-DOT LIFETIME GUARANTEE** on 6" instrument protects against defects in workmanship and material.

## NEW ENGINEERING • NEW DESIGN • NEW RANGES 30 RANGES

Voltage: 5 D.C. 0-10-50-250-500-1000 at 25000 ohms per volt.

5 A.C. 0-10-50-250-500-1000 at 1000 ohms per volt.

Current: 4 A.C. 0-.5-1-5-10 amp.

6 D.C. 0-50 microamperes—0-1-10-50-250 milliamperes—0-10 amperes.

4 Resistance 0-4000-40,000 ohms—4-40 megohms.

6 Decibel -10 to +15, +29, +43, +49, +55

Output Condenser in series with A.C. volt ranges.

Model 2400 is similar but has D.C. volts Ranges at 5000 ohms per volt.

Write for complete description

# Triplet

## ELECTRICAL INSTRUMENT CO.

BLUFFTON OHIO.

At this time attention is called to R1, a sensitivity resistor. It further reduces the negative bias to the lowest point consistent with stability. This resistor should not be installed until the set is tuned and tried out.

The 32L7 tube serves the double purpose of audio output tube and B-supply rectifier. Due to the excellent filtering throughout the set, resistor R10 can be 500 ohms, or less, at 2 watts. The values shown for C16 and C17 are about minimum, but higher values may be used.

The tubes shown on the schematic may be replaced by 12A8, 12SF7 and 70L7-GT, with some advantage gained. In the first place, a current-limiting resistor of about 160 ohms, 10 watts, can be mounted within the chassis, clear of all parts subject to injury. Then too, the 70L7 is a better amplifier than the 32L7. Note the different socket connections for the 70L7, and that a different socket with different connections is required for the 12SF7. This tube has but one diode plate, therefore, no connection is made to a second diode. All other parts, connections and values remain the same.

The 6J7 type tube may be used instead of the 7E7 (the 12J7 type instead of the 12SF7), the suppressor grid being used as the diode plate, as shown in *Radio-Craft* for September, 1945. When this type tube is used, the screen grid should be connected to prong 4 of the 6A8.

One of the unique features of this set is the method of connecting the volume control (R9) and the tone com-

pensation circuit (R8 and C19). (The value of R9 may be increased to one meg.) Note also that the output tube is brought within the a.v.c. circuit. Resistor R8 and condenser C19 are connected between the detector circuit and the tone tap on R9. The value of R8 can be 300,000 ohms; that of C19 200 mmf. An increase in the resistance or a decrease in the capacitance gives a brighter tone, and vice versa. This is the most efficient method of tone adjustment and noise suppression that I've found. The value of condenser C20 is not critical, and can be anything from .01 to .05.

Harmful radio-frequency feedback, or regeneration, is prevented by the network R7, C8, C11. The small amount of audio feedback passing through condenser C13 is grounded out in L4.

The noise level of the set is extremely low, due probably to the limited number of tubes and parts used.

To begin construction you will need a chassis, but this item aside from the cabinet is the last thing to procure by purchase or home manufacture. When all the parts have been acquired, arrange the layout on a substitute chassis or breadboard so that all leads will be as short and direct as possible, with all controls at the front panel. Grid and plate leads must be very short for best results. It's a good idea to keep leads as close to the chassis as practicable, since leads that stand out from some grounded metal object provide greater opportunity for harmful coupling.

(Continued on following page)

Attention! **HAMS**  
... FINISH YOUR OWN  
CRYSTALS



only  
**\$4.95**  
postpaid

**NEW**  
Complete Crystal  
Finishing Kit

Meet F.C.C. regulations for frequency control with Quartz Crystals. Finish your own crystals to meet your individual requirements. It's fun—it's easy—it's economical. Kit contains four AT

or BT low drift Quartz Crystals cut to U.S. Signal Corps wartime specification. Complete accessories including a holder with stainless steel hand lapped electrodes and special device for making limited frequency adjustments—flat glass grinding plates—coarse and fine special grinding abrasives—cleaning brush and syntex beads and complete instructions. Be sure to specify frequency desired so we can send blanks within easy grinding range.

**ALL AT AMAZING LOW COST—**  
Send money order, check or cash for your kit today.

**COMMERCIAL  
EQUIPMENT CO.**  
Dept. B  
1416 McGee Street  
Kansas City 6, Missouri

**FREE  
INSTRUCTION**



# Radio Headquarters

for 25 years



**We ship at once—parts, equipment, whatever you need!**

This house began its career almost as early as Broadcasting itself! Today, 25 years later, we're the world's largest radio supply house! **Standard Lines:** National, Hammarlund, R.C.A., Hallicrafters, Bud, Cardwell, Bliley, and all the others!



**SUPERSPEED SERVICE** Orders shipped out same day received, on most goods.



**ENGINEERING SERVICE** If your engineering problem requires special equipment, we'll make it

**FREE!**

Latest bargain flyer includes test instruments, record changers, communication receivers, ham transmitting tubes and a host of electronic items you need today.



Originators and Marketers of the Famous

*Lafayette Radio*

**Radio Wire Television Inc.**

NEW YORK 13 BOSTON 10 NEWARK 2

Cut out coupon, paste on penny post card, mail today

**R. W. T. Dept. JC-6**

100 AVENUE OF THE AMERICAS, NEW YORK 13

Gentlemen: Send me FREE copy of your Latest Bargain Flyer C-36, packed with latest electronic equipment and components.

NAME \_\_\_\_\_

ADDRESS \_\_\_\_\_

CITY \_\_\_\_\_ ZONE \_\_\_\_\_ STATE \_\_\_\_\_

## SUPER-REFLEX RADIO

(Continued from previous page)

In your tentative layout of parts, you may find that better wiring facilities can be obtained by changing one or more of the parts. Accordingly, juggle them around for the best possible plan. In some cases the position of a part may be as important as its value.

Chassis size will be determined largely by the size of the speaker used, and the diameter of choke coil L6 when this coil is mounted underneath. The size of the cabinet will be determined by size of speaker and chassis.

Fit the speaker to the chassis according to your plan, then lay it aside as the last thing to be permanently installed, to prevent possible injury to the cone.

Always wire the filament circuit first, according to the diagram, then insert the tubes and test by plugging in the line cord. If the tubes light, you will know that the wiring is correct to this point. Now remove the tubes and proceed with the remainder of the wiring.

Use rosin-core solder, the best you can obtain, but do not use it excessively.

Assuming the i.f. transformer, L3, is pre-tuned when purchased, use it as the beginning for tuning the other coils. Tune in a station near 1600 kc and adjust L1 and L2 for best results. Now adjust L4 and L5. Tune in a station near 600 kc to determine whether the set is tracking, for until you obtain accurate tracking you have a poor radio. A single turn more or less on L1 can change the tracking for better or worse. Now try adjusting the trimmers on L3 for better results, but first make certain of the original position of the adjusting screws.

The antenna can be anything from a few inches to several feet. One of six to ten feet should be sufficient if there are nearby stations.

Some means for checking the continuity of circuits and for shorts is almost a necessity. Even a flashlight battery and a bulb, or a d.c. voltmeter can be used. An open circuit means failure; a short can mean disaster.

With the exceptions noted, the value of the component parts for this set are not too critical. Substitutions may be made where necessary, but it should be remembered that the values specified are used in the original set.

With this set I am able (late October) to bring in speaker reception from KSL, over 600 air miles, around the clock; KOA, over 900 air miles, after 3:30 P.M.; and other good clear channel stations up to 3000 miles after 6:00 P.M.

The cabinet, tuning dial and chassis shown in the photographs are all home-made. The cabinet, made from materials taken from an apple crate, measures 7 $\frac{5}{8}$ x4 $\frac{1}{2}$ x5 $\frac{1}{2}$  inches; the chassis, made from aluminum, measures 7x4x1 $\frac{1}{2}$  inches. The dial is made from a disk of wood 3-16-inch thick and 2 $\frac{1}{4}$  inches in diameter, two old volume control bearings, a piece of fishing line for a belt and a tension spring.

## Order Your New Communications Receivers Now From RESCO—

**For Earliest Delivery!**



**ECHOPHONE EC - 1A**

Popular low-cost communications-type short-wave and broadcast receiver, with many new features. Covers entire tuning range from 550 kc. to 30 Mc. in 3 bands. For 115-125 volts AC-DC Electrical bandspread on all bands with separate tuning control and dial. Dial calibrated in megacycles. Beat frequency oscillator for CW reception. Automatic noise limiter. Built-in PM dynamic speaker. Headphones or speaker selected by panel switch. Housed in metal cabinet with gray wrinkle baked-on finish.

Net ..... **\$29.50**

**OTHER WELL-KNOWN RECEIVERS SUCH AS:**

Hallicrafters SX-25 .....	\$94.50
Hallicrafters S-20R .....	60.00
Hallicrafters S-22R .....	74.50
Hallicrafters S-39 .....	110.00
National HRO .....	197.70
PM23 Speaker .....	15.00

## RADIO ELECTRIC SERVICE COMPANY

*Everything in Radio and Electronics*

N. W. Cor. 7th and Arch Sts., PHILADELPHIA 6, PA.

Radio Elec. Serv. Co. 701 Arch St., Phila. 6, Pa. Date .....

Please enter Order for:

..... MODEL .....

..... Enclosed \$..... MONEY ORDER ..... CHECK .....

..... Please send full information on Communications Receivers.

NAME .....

ADDRESS .....

CITY ..... ZONE ... STATE .....



## IMPROVED COMPENSATOR

By F. C. DAVIS

**S**EARCHING for a really effective tone compensator, I have built and tried out every compensator which I have found diagrammed in books and magazines—eight or ten in all. Unfortunately every one of them left something to be desired.

For example, Nelson's hi-lo control, *Radio-Craft* for March 1945, page 362, doesn't boost the highs enough and its bass control affects the volume too much. Stang's equalizer, January-February issue 1942, page 347, is only moderately effective. Maler's compensator, August 1945, page 178, is a step in the right direction, but was evidently designed for a special case; it's much too heavy on the bass even with the bass control turned to minimum, and it fails to realize full treble boost due to the voltage-divider shown in connection with the treble control. Moreover, the two 6N7's draw a filament current of 1.6 amperes, which might overload an existing receiver or amplifier, necessitating occasionally a separate filament transformer.

Going back to simple fundamentals, I contrived the tone compensator diagrammed here. It is thoroughly conventional, very simple and the most effective compensator I have ever found. It uses only standard resistors and capacitors—no chokes to pick up inductive hum—and its separate controls for bass and treble have absolutely no interaction. It produces a concave response curve, the depth of which can be varied to any desired degree, which is exactly the correct effect for music played at low volume or moderate volume. It will also boost or attenuate either highs or lows alone.

The incoming signal is split between two channels. The upper channel handles the treble. The use of small coupling condensers, small cathode by-pass condensers, and resistors of low value in both the plate and the grid

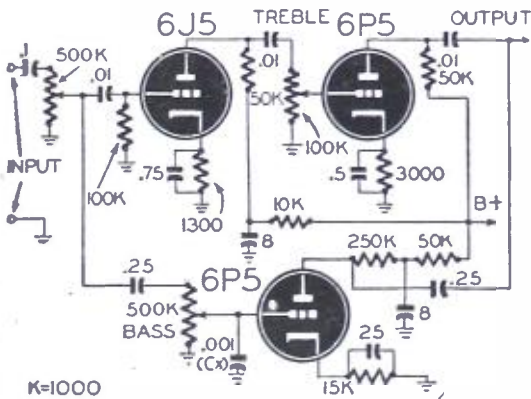

circuits, all tend to attenuate the lows. The lower channel handles the bass and is a straight stage of resistance-coupled amplification except for the condenser  $C_x$  shunted between grid and ground—an old-style "tone control," this one being fixed.

This compensator can be easily adapted to any given audio situation. (I de-

## HARRISON HAS IT!

### ALL STANDARD LINES

We are Factory Authorized Distributors for the top quality manufacturers and we now have in stock lots more new, latest improved production Ham gear! Visit our stores today, for everything you need. We promise you fresh, clean material—quicker—at the lowest current prices—and, above all, our sincere desire to be of friendly, helpful service.

**MAIL ORDERS?**—Certainly! Just list everything you want and include deposit or full amount. (Please add postage if you want parcel post shipment.)

731 de  
BTL Harrison, W2AVA

### NEW! HALLICRAFTER SKYRIDER, JR.

A fine little six-tube receiver that is a worthy successor to the world famous Echobond 1C 17 AC-DC—three bands, 550 Kc to 30 Mc—electrical bandspread—noise limiter—built-in speaker. Gray or white cabinet (state preference).

Model S-41 ..... \$33.50

### HALLICRAFTER SKY CHAMPION

Here's the first completely new post-war model. As usual—Harrison will be among the very first to have these receivers in stock for immediate delivery! So rush in your order right now.

Model S-40, Complete ..... \$79.50

### HALLICRAFTER

SX-28A ..... \$223.00

PM-23 ..... 15.00

S-20R ..... 60.00

S-22R ..... 74.50

SX-25 ..... 94.50

S-36A ..... 415.00

S-37 ..... 571.75

S-39 ..... 110.00

### ASK FOR HALLICRAFTER CATALOG

### TEST EQUIPMENT

We are prepared to supply your every Test Equipment requirement—from the smallest pocket battery checker to a complete test laboratory—with the products of all well known manufacturers. Your inquiries and orders are solicited—deliveries from Harrison are quicker than you might expect!

### Brush PL-20 TRANSCRIPTION PICKUP

One of the finest! High output with wide range response. With equalizer for "Constant Velocity" recordings.

New Shure "Gilder" pickup ..... \$26.40

..... \$3.23

### MILLEN TRANSMITTER-EAC-ER

Four bands on one crystal. Output 10 to 50 watts standard. 10" x 3 1/2" rack panel. Requires up to 750 V DC at 250 MA for plates. Meter switches into either plate circuit.

Can be used as transmitter or as driver for hi-power final.

#90800, with one set of coils ..... \$37.50

Tubes ..... \$3.40

**IF YOU WANT to be among the very first to get any new, or not immediately available equipment, put your name on our "Preferred List."**

The factories owe us plenty—and as it comes in we rush it right out!

You can make sure of getting yours quicker by telling us now what you want. (Naturally, orders with deposit come first.) If you change your mind you can cancel at anytime before shipment without obligation.

## HARRISON HAS IT!

### HSS HARRISON SELECT SURPLUS

Your assurance of good, usable, guaranteed, surplus material at seasonally low prices—top value always! Come in and browse through our large, entirely separate HSS Department (Harrison Select Surplus).

### SIGNAL CORPS CODE TRAINING SETS

Operates on 0, 12, 24, or 110 DC or 115, 230 V. Volt. Built-in speaker or can put up to 100 headphones. Price \$100 to \$2000, except 12 volume controls, 110 or 115 for school use, collect for code in communication groups, etc. New, with tubes, in metal carrying case ..... \$23.75

### HSS TUBES

All new, fully guaranteed, top quality tubes. 24G (6X4) 120A1 (6X4) 102A1 (6X4) 102A2 (6X4) 102A3 (6X4) 102A4 (6X4) 102A5 (6X4) 102A6 (6X4) 102A7 (6X4) 102A8 (6X4) 102A9 (6X4) 102A10 (6X4) 102A11 (6X4) 102A12 (6X4) 102A13 (6X4) 102A14 (6X4) 102A15 (6X4) 102A16 (6X4) 102A17 (6X4) 102A18 (6X4) 102A19 (6X4) 102A20 (6X4) 102A21 (6X4) 102A22 (6X4) 102A23 (6X4) 102A24 (6X4) 102A25 (6X4) 102A26 (6X4) 102A27 (6X4) 102A28 (6X4) 102A29 (6X4) 102A30 (6X4) 102A31 (6X4) 102A32 (6X4) 102A33 (6X4) 102A34 (6X4) 102A35 (6X4) 102A36 (6X4) 102A37 (6X4) 102A38 (6X4) 102A39 (6X4) 102A40 (6X4) 102A41 (6X4) 102A42 (6X4) 102A43 (6X4) 102A44 (6X4) 102A45 (6X4) 102A46 (6X4) 102A47 (6X4) 102A48 (6X4) 102A49 (6X4) 102A50 (6X4) 102A51 (6X4) 102A52 (6X4) 102A53 (6X4) 102A54 (6X4) 102A55 (6X4) 102A56 (6X4) 102A57 (6X4) 102A58 (6X4) 102A59 (6X4) 102A60 (6X4) 102A61 (6X4) 102A62 (6X4) 102A63 (6X4) 102A64 (6X4) 102A65 (6X4) 102A66 (6X4) 102A67 (6X4) 102A68 (6X4) 102A69 (6X4) 102A70 (6X4) 102A71 (6X4) 102A72 (6X4) 102A73 (6X4) 102A74 (6X4) 102A75 (6X4) 102A76 (6X4) 102A77 (6X4) 102A78 (6X4) 102A79 (6X4) 102A80 (6X4) 102A81 (6X4) 102A82 (6X4) 102A83 (6X4) 102A84 (6X4) 102A85 (6X4) 102A86 (6X4) 102A87 (6X4) 102A88 (6X4) 102A89 (6X4) 102A90 (6X4) 102A91 (6X4) 102A92 (6X4) 102A93 (6X4) 102A94 (6X4) 102A95 (6X4) 102A96 (6X4) 102A97 (6X4) 102A98 (6X4) 102A99 (6X4) 102A100 (6X4) 102A101 (6X4) 102A102 (6X4) 102A103 (6X4) 102A104 (6X4) 102A105 (6X4) 102A106 (6X4) 102A107 (6X4) 102A108 (6X4) 102A109 (6X4) 102A110 (6X4) 102A111 (6X4) 102A112 (6X4) 102A113 (6X4) 102A114 (6X4) 102A115 (6X4) 102A116 (6X4) 102A117 (6X4) 102A118 (6X4) 102A119 (6X4) 102A120 (6X4) 102A121 (6X4) 102A122 (6X4) 102A123 (6X4) 102A124 (6X4) 102A125 (6X4) 102A126 (6X4) 102A127 (6X4) 102A128 (6X4) 102A129 (6X4) 102A130 (6X4) 102A131 (6X4) 102A132 (6X4) 102A133 (6X4) 102A134 (6X4) 102A135 (6X4) 102A136 (6X4) 102A137 (6X4) 102A138 (6X4) 102A139 (6X4) 102A140 (6X4) 102A141 (6X4) 102A142 (6X4) 102A143 (6X4) 102A144 (6X4) 102A145 (6X4) 102A146 (6X4) 102A147 (6X4) 102A148 (6X4) 102A149 (6X4) 102A150 (6X4) 102A151 (6X4) 102A152 (6X4) 102A153 (6X4) 102A154 (6X4) 102A155 (6X4) 102A156 (6X4) 102A157 (6X4) 102A158 (6X4) 102A159 (6X4) 102A160 (6X4) 102A161 (6X4) 102A162 (6X4) 102A163 (6X4) 102A164 (6X4) 102A165 (6X4) 102A166 (6X4) 102A167 (6X4) 102A168 (6X4) 102A169 (6X4) 102A170 (6X4) 102A171 (6X4) 102A172 (6X4) 102A173 (6X4) 102A174 (6X4) 102A175 (6X4) 102A176 (6X4) 102A177 (6X4) 102A178 (6X4) 102A179 (6X4) 102A180 (6X4) 102A181 (6X4) 102A182 (6X4) 102A183 (6X4) 102A184 (6X4) 102A185 (6X4) 102A186 (6X4) 102A187 (6X4) 102A188 (6X4) 102A189 (6X4) 102A190 (6X4) 102A191 (6X4) 102A192 (6X4) 102A193 (6X4) 102A194 (6X4) 102A195 (6X4) 102A196 (6X4) 102A197 (6X4) 102A198 (6X4) 102A199 (6X4) 102A200 (6X4) 102A201 (6X4) 102A202 (6X4) 102A203 (6X4) 102A204 (6X4) 102A205 (6X4) 102A206 (6X4) 102A207 (6X4) 102A208 (6X4) 102A209 (6X4) 102A210 (6X4) 102A211 (6X4) 102A212 (6X4) 102A213 (6X4) 102A214 (6X4) 102A215 (6X4) 102A216 (6X4) 102A217 (6X4) 102A218 (6X4) 102A219 (6X4) 102A220 (6X4) 102A221 (6X4) 102A222 (6X4) 102A223 (6X4) 102A224 (6X4) 102A225 (6X4) 102A226 (6X4) 102A227 (6X4) 102A228 (6X4) 102A229 (6X4) 102A230 (6X4) 102A231 (6X4) 102A232 (6X4) 102A233 (6X4) 102A234 (6X4) 102A235 (6X4) 102A236 (6X4) 102A237 (6X4) 102A238 (6X4) 102A239 (6X4) 102A240 (6X4) 102A241 (6X4) 102A242 (6X4) 102A243 (6X4) 102A244 (6X4) 102A245 (6X4) 102A246 (6X4) 102A247 (6X4) 102A248 (6X4) 102A249 (6X4) 102A250 (6X4) 102A251 (6X4) 102A252 (6X4) 102A253 (6X4) 102A254 (6X4) 102A255 (6X4) 102A256 (6X4) 102A257 (6X4) 102A258 (6X4) 102A259 (6X4) 102A260 (6X4) 102A261 (6X4) 102A262 (6X4) 102A263 (6X4) 102A264 (6X4) 102A265 (6X4) 102A266 (6X4) 102A267 (6X4) 102A268 (6X4) 102A269 (6X4) 102A270 (6X4) 102A271 (6X4) 102A272 (6X4) 102A273 (6X4) 102A274 (6X4) 102A275 (6X4) 102A276 (6X4) 102A277 (6X4) 102A278 (6X4) 102A279 (6X4) 102A280 (6X4) 102A281 (6X4) 102A282 (6X4) 102A283 (6X4) 102A284 (6X4) 102A285 (6X4) 102A286 (6X4) 102A287 (6X4) 102A288 (6X4) 102A289 (6X4) 102A290 (6X4) 102A291 (6X4) 102A292 (6X4) 102A293 (6X4) 102A294 (6X4) 102A295 (6X4) 102A296 (6X4) 102A297 (6X4) 102A298 (6X4) 102A299 (6X4) 102A300 (6X4) 102A301 (6X4) 102A302 (6X4) 102A303 (6X4) 102A304 (6X4) 102A305 (6X4) 102A306 (6X4) 102A307 (6X4) 102A308 (6X4) 102A309 (6X4) 102A310 (6X4) 102A311 (6X4) 102A312 (6X4) 102A313 (6X4) 102A314 (6X4) 102A315 (6X4) 102A316 (6X4) 102A317 (6X4) 102A318 (6X4) 102A319 (6X4) 102A320 (6X4) 102A321 (6X4) 102A322 (6X4) 102A323 (6X4) 102A324 (6X4) 102A325 (6X4) 102A326 (6X4) 102A327 (6X4) 102A328 (6X4) 102A329 (6X4) 102A330 (6X4) 102A331 (6X4) 102A332 (6X4) 102A333 (6X4) 102A334 (6X4) 102A335 (6X4) 102A336 (6X4) 102A337 (6X4) 102A338 (6X4) 102A339 (6X4) 102A340 (6X4) 102A341 (6X4) 102A342 (6X4) 102A343 (6X4) 102A344 (6X4) 102A345 (6X4) 102A346 (6X4) 102A347 (6X4) 102A348 (6X4) 102A349 (6X4) 102A350 (6X4) 102A351 (6X4) 102A352 (6X4) 102A353 (6X4) 102A354 (6X4) 102A355 (6X4) 102A356 (6X4) 102A357 (6X4) 102A358 (6X4) 102A359 (6X4) 102A360 (6X4) 102A361 (6X4) 102A362 (6X4) 102A363 (6X4) 102A364 (6X4) 102A365 (6X4) 102A366 (6X4) 102A367 (6X4) 102A368 (6X4) 102A369 (6X4) 102A370 (6X4) 102A371 (6X4) 102A372 (6X4) 102A373 (6X4) 102A374 (6X4) 102A375 (6X4) 102A376 (6X4) 102A377 (6X4) 102A378 (6X4) 102A379 (6X4) 102A380 (6X4) 102A381 (6X4) 102A382 (6X4) 102A383 (6X4) 102A384 (6X4) 102A385 (6X4) 102A386 (6X4) 102A387 (6X4) 102A388 (6X4) 102A389 (6X4) 102A390 (6X4) 102A391 (6X4) 102A392 (6X4) 102A393 (6X4) 102A394 (6X4) 102A395 (6X4) 102A396 (6X4) 102A397 (6X4) 102A398 (6X4) 102A399 (6X4) 102A400 (6X4) 102A401 (6X4) 102A402 (6X4) 102A403 (6X4) 102A404 (6X4) 102A405 (6X4) 102A406 (6X4) 102A407 (6X4) 102A408 (6X4) 102A409 (6X4) 102A410 (6X4) 102A411 (6X4) 102A412 (6X4) 102A413 (6X4) 102A414 (6X4) 102A415 (6X4) 102A416 (6X4) 102A417 (6X4) 102A418 (6X4) 102A419 (6X4) 102A420 (6X4) 102A421 (6X4) 102A422 (6X4) 102A423 (6X4) 102A424 (6X4) 102A425 (6X4) 102A426 (6X4) 102A427 (6X4) 102A428 (6X4) 102A429 (6X4) 102A430 (6X4) 102A431 (6X4) 102A432 (6X4) 102A433 (6X4) 102A434 (6X4) 102A435 (6X4) 102A436 (6X4) 102A437 (6X4) 102A438 (6X4) 102A439 (6X4) 102A440 (6X4) 102A441 (6X4) 102A442 (6X4) 102A443 (6X4) 102A444 (6X4) 102A445 (6X4) 102A446 (6X4) 102A447 (6X4) 102A448 (6X4) 102A449 (6X4) 102A450 (6X4) 102A451 (6X4) 102A452 (6X4) 102A453 (6X4) 102A454 (6X4) 102A455 (6X4) 102A456 (6X4) 102A457 (6X4) 102A458 (6X4) 102A459 (6X4) 102A460 (6X4) 102A461 (6X4) 102A462 (6X4) 102A463 (6X4) 102A464 (6X4) 102A465 (6X4) 102A466 (6X4) 102A467 (6X4) 102A468 (6X4) 102A469 (6X4) 102A470 (6X4) 102A471 (6X4) 102A472 (6X4) 102A473 (6X4) 102A474 (6X4) 102A475 (6X4) 102A476 (6X4) 102A477 (6X4) 102A478 (6X4) 102A479 (6X4) 102A480 (6X4) 102A481 (6X4) 102A482 (6X4) 102A483 (6X4) 102A484 (6X4) 102A485 (6X4) 102A486 (6X4) 102A487 (6X4) 102A488 (6X4) 102A489 (6X4) 102A490 (6X4) 102A491 (6X4) 102A492 (6X4) 102A493 (6X4) 102A494 (6X4) 102A495 (6X4) 102A496 (6X4) 102A497 (6X4) 102A498 (6X4) 102A499 (6X4) 102A500 (6X4) 102A501 (6X4) 102A502 (6X4) 102A503 (6X4) 102A504 (6X4) 102A505 (6X4) 102A506 (6X4) 102A507 (6X4) 102A508 (6X4) 102A509 (6X4) 102A510 (6X4) 102A511 (6X4) 102A512 (6X4) 102A513 (6X4) 102A514 (6X4) 102A515 (6X4) 102A516 (6X4) 102A517 (6X4) 102A518 (6X4) 102A519 (6X4) 102A520 (6X4) 102A521 (6X4) 102A522 (6X4) 102A523 (6X4) 102A524 (6X4) 102A525 (6X4) 102A526 (6X4) 102A527 (6X4) 102A528 (6X4) 102A529 (6X4) 102A530 (6X4) 102A531 (6X4) 102A532 (6X4) 102A533 (6X4) 102A534 (6X4) 102A535 (6X4) 102A536 (6X4) 102A537 (6X4) 102A538 (6X4) 102A539 (6X4) 102A540 (6X4) 102A541 (6X4) 102A542 (6X4) 102A543 (6X4) 102A544 (6X4) 102A545 (6X4) 102A546 (6X4) 102A547 (6X4) 102A548 (6X4) 102A549 (6X4) 102A550 (6X4) 102A551 (6X4) 102A552 (6X4) 102A553 (6X4) 102A554 (6X4) 102A555 (6X4) 102A556 (6X4) 102A557 (6X4) 102A558 (6X4) 102A559 (6X4) 102A560 (6X4) 102A561 (6X4) 102A562 (6X4) 102A563 (6X4) 102A564 (6X4) 102A565 (6X4) 102A566 (6X4) 102A567 (6X4) 102A568 (6X4) 102A569 (6X4) 102A570 (6X4) 102A571 (6X4) 102A572 (6X4) 102A573 (6X4) 102A574 (6X4) 102A575 (6X4) 102A576 (6X4) 102A577 (6X4) 102A578 (6X4) 102A579 (6X4) 102A580 (6X4) 102A581 (6X4) 102A582 (6X4) 102A583 (6X4) 102A584 (6X4) 102A585 (6X4) 102A586 (6X4) 102A587 (6X4) 102A588 (6X4) 102A589 (6X4) 102A590 (6X4) 102A591 (6X4) 102A592 (6X4) 102A593 (6X4) 102A594 (6X4) 102A595 (6X4) 102A596 (6X4) 102A597 (6X4) 102A598 (6X4) 102A599 (6X4) 102A600 (6X4) 102A601 (6X4) 102A602 (6X4) 102A603 (6X4) 102A604 (6X4) 102A605 (6X4) 102A606 (6X4) 102A607 (6X4) 102A608 (6X4) 102A609 (6X4) 102A610 (6X4) 102A611 (6X4) 102A612 (6X4) 102A613 (6X4) 102A614 (6X4) 102A615 (6X4) 102A616 (6X4) 102A617 (6X4) 102A618 (6X4) 102A619 (6X4) 102A620 (6X4) 102A621 (6X4) 102A622 (6X4) 102A623 (6X4) 102A624 (6X4) 102A625 (6X4) 102A626 (6X4) 102A627 (6X4) 102A628 (6X4) 102A629 (6X4) 102A630 (6X4) 102A631 (6X4) 102A632 (6X4) 102A633 (6X4) 102A634 (6X4) 102A635 (6X4) 102A636 (6X4) 102A637 (6X4) 102A638 (6X4) 102A639 (6X4) 102A640 (6X4) 102A641 (6X4) 102A642 (6X4) 102A643 (6X4) 102A644 (6X4) 102A645 (6X4) 102A646 (6X4) 102A647 (6X4) 102A648 (6X4) 102A649 (6X4) 102A650 (6X4) 102A651 (6X4) 102A652 (6X4) 102A653 (6X4) 102A654 (6X4) 102A655 (6X4) 102A656 (6X4) 102A657 (6X4) 102A658 (6X4) 102A659 (6X4) 102A660 (6X4) 102A661 (6X4) 102A662 (6X4) 102A663 (6X4) 102A664 (6X4) 102A665 (6X4) 102A666 (6X4) 102A667 (6X4) 102A668 (6X4) 102A669 (6



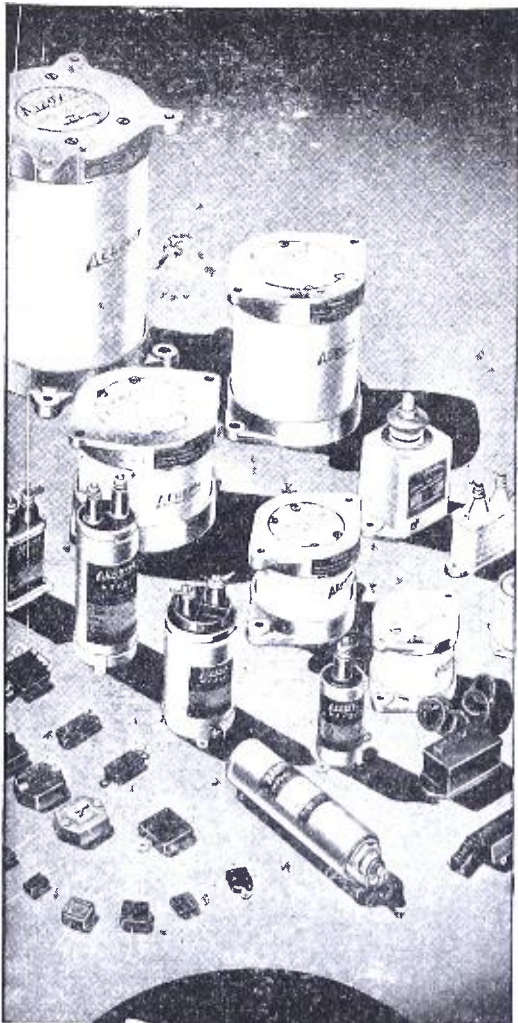

● Hats off to these veterans! They have served with rare distinction on many battle fronts—on land, on sea, and in the air. And now that the needs of our fighting men have been fully met and the victory clinched, these heavy-duty mica, oil-filled, paper and electrolytic capacitors are once more generally available. Because of their outstanding wartime service, they will be still better prepared to meet those heavy-duty service requirements of post-war radio and electronics. ● Consult our local jobber. Or write us.



**FOR RADIO-ELECTRONIC AND INDUSTRIAL APPLICATIONS**

AEROVOX CORP., NEW BEDFORD, MASS., U.S.A.  
 Export: 13 E. 40th St., New York 16, N.Y. • Cable: 'ARLAB'  
 In Canada: AEROVOX CANADA LTD., Hamilton, Ont.

## LIMITING CIRCUITS

(Continued from page 397)

from conducting during all of the positive and most of the negative alternations. But when the negative swing of the input exceeds the voltage  $E$ , the tube conducts and this energy is dissipated in resistor  $R_2$ .

Reversal of the voltage  $E$  permits the same circuit to provide negative limiting above ground (Fig. 10). In this case, the diode conducts at all times except when the positive alternations exceed in amplitude the voltage  $E$ . The output of this parallel diode limiter is a series of positive-going impulses.

### DOUBLE DIODE LIMITERS

Since one parallel diode can be used to limit either positive or negative extremities of an input signal, it is apparent that two diodes can be used to limit both amplitudes in the same circuit.

Such an arrangement is shown in Fig. 11, where positive and negative limiting is performed by two diodes, or a double diode. Maximum amplitudes of the output  $E_o$  depends upon the values of the fixed bias voltage for each diode. Output is developed across the load resistor  $R$ .

An examination of the output wave reveals that this circuit (Fig. 11) is a simple means of producing a square or rectangular wave output from a sine wave input. The circuit is occasionally used in electronics for this sole purpose.

Two series diode limiters could be connected together to perform a similar, double-limiting function, but such an arrangement requires much more critical adjustment and is seldom used.

### GRID LIMITING

Any triode, tetrode, or pentode can be operated as a limiter by utilizing the cathode-grid circuit in the manner of a simple parallel diode. The circuit (Fig. 12) requires the use of a large series grid resistor  $R_2$ , which acts very much as a grid leak.

During negative cycles of the input  $E_s$ , no grid current flows in the circuit. There is no voltage drop across the resistor  $R_2$  and the entire input signal appears between the grid and cathode of the tube.

When grid current flows, however, during a portion of the positive alternations of the input, there is a voltage drop across the large grid resistor—leaving only a small part of the positive input voltage to be applied to the tube.

The point at which grid current begins to flow is determined by the bias " $E$ ," developed between grid and cathode by the flow of plate current through the cathode resistor  $R_1$ . This effective bias voltage " $E$ " establishes the limiter level.

Grid of the tube is normally at ground potential, and thus is negative with respect to the cathode. Positive alternations drive the grid positive by an

amount equal to the voltage value " $E$ ," before the bias effect of the cathode resistor is removed. Any further rise in the positive input signal then results in attenuation by the grid circuit.

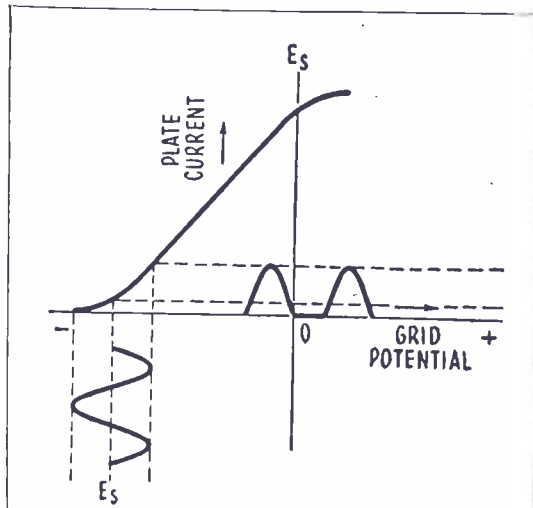

Fig. 13(a)—Plate cut-off negative limiting.

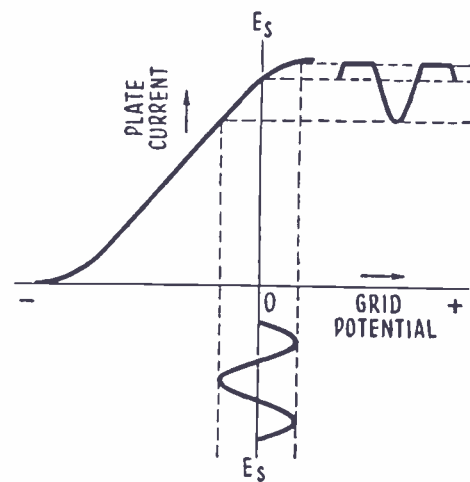

Fig. 13(b)—Positive limiting by saturation.

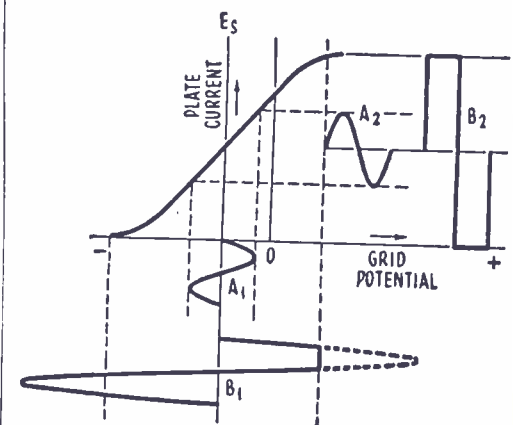

Fig. 14—Waveform from overdriven amplifier.

Negative portions of the input are passed by this circuit without change or limiting.

### CUT-OFF AND SATURATION

Ordinary triodes, tetrodes, and pentodes can also be operated under conditions resulting in two other types of limiting action.

Considering the  $I_p$ - $E_g$  characteristic curve for any triode, a central portion



## ATTENTION, MANUFACTURERS!

### EX-SERVICEMAN

with new Sales Engineering organization wants lines of the following that can be offered clientele without reservation: Refrigeration & Air Cond.—Ind., Comm., Dom.; Radio—Rec., Parts, Access.; Sound—Inter-Com., P.A., Rec., 16 mm-35 mm, etc.; Motors—Dom. & Ind.; Diesel-Elec. plants; Industrial Electronic devices; Lab. & Test Eqpt.; Telephone—L. Bat., Com. Bat., Auto.-Swbds.; sets, parts; and all kinds of Hand & Power Tools; Supplies & Accessories for all branches of the Elec. field. Desire to purchase on wholesale basis, this organization to assume full responsibility of all guarantees.

**KENNETH R. RUDISILL**

ELEC. ENGINEER

BOX 337 IOWA FALLS, IOWA

## • Ted McElroy

World's Largest Manufacturer of  
Wireless Telegraphic Apparatus

COMPLETE CENTRAL OFFICE EQUIPMENT

**McElroy Manufacturing Corp.**

82 Brankline Avenue • Boston, Massachusetts

of the curve will usually be almost linear—permitting distortion-free amplification of input signals.

However, if the tube is operated at or near the end (non-linear) regions of the curve, the output wave will be distorted.

For example, the operating point on the characteristic curve could be chosen at such a value that the negative portions of the input signal would swing the tube beyond cut-off. (See Fig. 13 [a].) The negative alternation would then have some part of its extremity removed, but the positive cycle would be unaffected. This is known as *cut-off limiting* in an amplifier.

If the operating point is chosen near the point of saturation on the characteristic curve (Fig. 13 [b]), the positive portion of the wave would be distorted and limited, while the negative part of each cycle would not be affected. This is known as *saturation limiting* in an amplifier.

The chief value of these two new forms of limiting is that they may be combined in a single amplifier to provide both positive and negative limiting with a single tube.

All that is required is an input signal of such great amplitude that (1) it drives the amplifier tube far into the cut-off region on negative alternations, and (2) it drives the tube far beyond the saturation region on positive alternations (Fig. 14).

Such a device is known as an over-driven amplifier. The combination of cut-off and saturation limiting is used to produce a square or rectangular wave from a high-amplitude input sine wave.

Referring to Fig. 14, assume that the normal input  $A_1$  of 50 volts results in a linear output  $A_2$ . The triode, however, is purposely operated with an excessive input  $B_1$  of 400 volts, or higher. Then, as the grid swings positive a condition of saturation will be reached quickly—and the output  $B_2$  will have risen to its greatest possible value. As the grid attempts to go more positive due to the driving influence of the input signal,

more and more grid current will be drawn by the amplifier tube. The high impedance driving source will be incapable of effecting a further increase in the grid voltage. Thus, the output wave will remain at constant amplitude, until the signal input wave has proceeded in its cycle and returns to the linear portion of the characteristic curve.

Once this region of linearity is reached, the output wave will fall proportionately with a decrease in grid voltage until it reaches the cut-off point. From that point any further decrease in grid voltage has no effect on the output wave, since it cannot be reduced below zero. Therefore, the output will remain at zero until the signal wave continues in its cycle and enters the region where the tube will pass plate current again, when the entire process is repeated.

Thus, two characteristic limitations of an amplifier can be utilized to produce a steep-sided square or rectangular output wave.

A "Bibliography of Scientific and Industrial Reports Distributed by the Office of the Publication Board" has been placed on sale by the Superintendent of Documents, Government Printing Office.

The bibliography is to be issued weekly. It is a catalog containing titles and prices of reports obtainable from OPB. These reports include information on scientific and technical developments, processes and inventions formerly subject to security restrictions. Price (and size) of the weekly bibliographers will vary, the OPB stated.

### Technical Term Illustrated

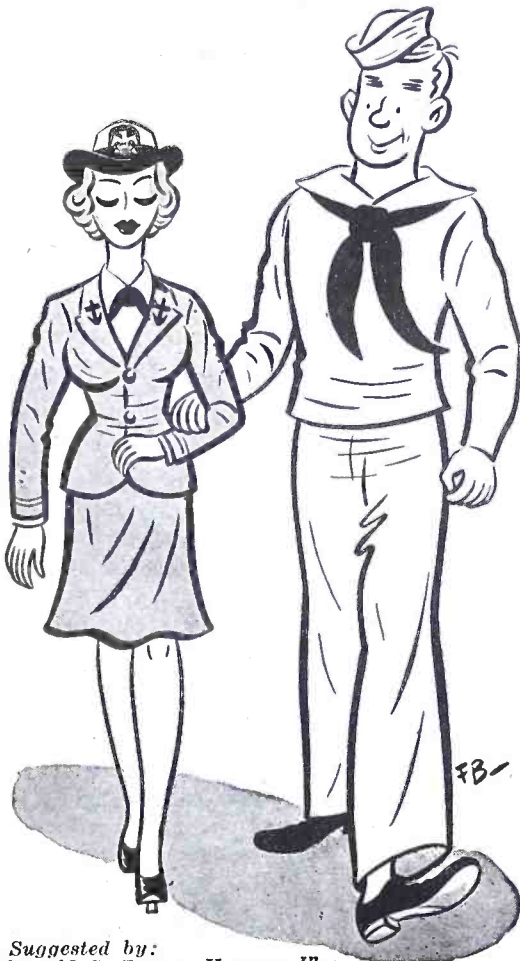

Suggested by:  
Harold S. Renne, Harvey, Ill.

"Wave Guide"

for everything in

**ELECTRONICS**

and **EQUIPMENT**

follow

**ARROW!**

*An Exceptional Value!*

### 3 Tube AC-DC PHONO AMPLIFIER

Completely wired, with tubes and ready to operate. Uses a dynamic speaker 450 ohm field. Tubes: 143B, 50A5 and 35Z5. Complete with tubes, less speaker.

Only **\$7.95** net

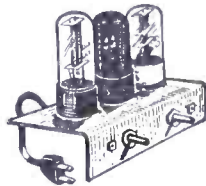

### TURNER MICROPHONES

Model 22X Crystal (illustrated)

Reproduces clean and sharp. Tilting head. Removable 7 foot cable. Built-in windgag for outdoor operation. High level -52DB. Range 30-7,000 cycles. **\$10.88** net



Model 99 Dynamic-Level -52DB. Range 40-9,000 cycles. 20 foot cable, net \$19.11

*We Carry a Complete Stock of  
SHURE, AMERICAN, ASTATIC and  
ELECTROVOICE Microphones.*

### SUPERIOR Model PB-100 VOLT-OHM- MILLI- AMMETER

All-purpose test instrument. Direct reading, push-button operation. Self-contained battery. Hand-rubbed oak cabinet. **\$28.40** net

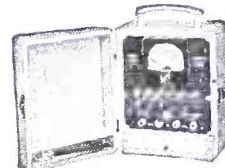

Specifications:

D.C. VOLTAGE: 0 to 5/25/50/250/500/2500.  
A.C. VOLTAGE: 0 to 10/50/100/500/1000.  
OUTPUT METER: 0 to 10/50/100/500/1000 Volts.  
D.C. CURRENT: 0 to 10/250 Ma. 0 to 2.5 Amp.  
RESISTANCE: 0 to 10,000/100,000 Ohms, 0-1 Meg.  
DECIBELS: -10 to +15; 0 to +35; +30 to +55.

### Attention . . . HAMS

*We Carry Full Stocks of  
BARKER & WILLIAMS*

**COILS** (25 watts to 1 KW. All bands including 15 meters)  
**G.E. TRANSMITTING TUBES**  
**BUDD RADIO PRODUCTS**  
**STANGOR TRANSFORMERS**  
**HUDSON AMERICAN TRANSFORMERS**  
**CARDWELL VARIABLE CONDENSERS**

Write to us for anything in ELECTRONIC PARTS and EQUIPMENT. Get on our mailing list and keep informed as merchandise becomes available.

**ARROW**  
**ELECTRONICS COMPANY**

82 CORTLANDT ST., NEW YORK 7, N. Y.

COrlandt 7-2935 — 2998



# Highest Quality RADIO & ELECTRONIC TESTING EQUIPMENT

Immediate Delivery  
from Stock Guaranteed

The New Model 447

## AC-DC Multitester

Net Price  
**\$17.95**

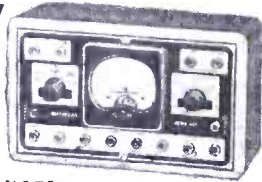

RANGES:

DC Voltmeter: 0-5-50-250-500-2500 volts  
AC Voltmeter: 0-10-100-500-1000 volts  
Output Voltmeter: 0-10-100-500-1000 volts  
DC Milliammeter: 0-1-10-100-1000 milliamperes  
DC Ammeter: 0-10 Amperes  
Ohmmeter: 0-500-100000 Ohm, 1 Megohm  
Decibel Meter: minus 8 to plus 55 Decibels

The New Model 448

## Pocket Multitester

Net Price **\$24.50**

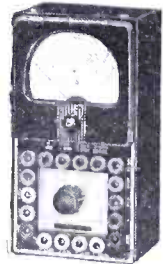

RANGES:

DC Voltmeter: 0-5-50-250-1000 volts—first scale division -0.1 volt  
AC Voltmeter: 0-5-50-250-1000 volts—first scale division -0.1 volt  
Output Voltmeter: 0-5-50-250-1000 volts—first scale division -0.1 volt  
DC Milliammeter: 0-5-10-100-1000 MA—first scale division -0.1 MA  
Ohmmeter: 0/1000, 0/10000, 0/1 meg, 0/1 meg  
Decibel Meter: -6 to 10, -14 to plus 26, -28 to plus 40, -40 to plus 52DB

The New Model 705

## SIGNAL GENERATOR

Net Price **\$49.50**

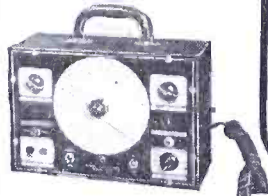

RANGES:

From 95 kc to 100 mc, continuously variable. Calibration accurate to 2% through broadcast bands, within 3% for high frequency bands. Planetary drive condenser, direct reading calibration, output modulated or unmodulated. Self-contained electronic modulation 400c sine wave available for external use. Special feature provided in having two degrees of modulation at both approx. 30% and 80%.

The New Model 802N

## Combination TUBE & SET TESTER

Net Price **\$59.50**



RANGES:

DC Voltmeter: 0/10/50/500/1000 at 1000 ohms per volt  
Four Range AC Voltmeter: 0/10/50/500/1000  
DC Milliammeter: 0/1/10/1000 DC Ammeter 0/10  
DB Meter: -8/15/15 to 29/29/ to 49/32 to 55 decibels  
Four Range Output Meter—same as AC Volts

SUPERIOR Model CA-11 Signal Tracer ..... 18.75  
SUPERIOR Model 1553 Volt Ohm Milliammeter 24.75  
SUPERIOR Model PB-100 ..... 28.40  
SUPERIOR Model PB-210 Multitester ..... 35.75  
SUPERIOR Model 450 Tube Tester ..... 39.50  
SUPERIOR Model 720 MultiRange AC Ammet 49.50  
SUPERIOR Model 400 Electronic Multitester... 52.50  
R.C.P. Model 661A Sensitive Multitester .... 39.50  
R.C.P. Model 668 Vacuum Tube AC-DC Voltmeter ..... 74.50  
R.C.P. Model 805 Tube and Set Tester ..... 89.50

Write for our new 12-page free catalog.

# Metropolitan

ELECTRONIC & INSTRUMENT CO.

Dept. C, 6 MURRAY STREET  
NEW YORK 7, N. Y., U. S. A.

Phone: BARclay 7-5556

Cable Address: METRONICS

## H. F. CRYSTAL DIODES

(Continued from page 386)

subjected to high electrostatic or magnetic fields. Another precaution is that before inserting a crystal in its holder, the operator should ground himself by touching the apparatus. In this way one may eliminate the danger of a high surge current due to a potential difference between the operator and the set.

### HIGH CURRENTS AND VOLTAGES

The silicon crystal diodes developed for radar use were designed to operate at 1 or 2 ma. More recent developments have produced a germanium crystal diode, the type 1N34, which is electrically much more rugged than its predecessors, and which is useful in many applications up to 500 Mc. The peak inverse anode voltage is 50 volts. It is rated at an average anode current of 22.5 ma and will withstand peak currents of 60 ma or surges even up to 200 ma.

Small interelectrode capacitances and the ability to work into a low resistive load with high efficiency are two requirements imposed on detectors for use in frequency modulation and television equipment. The type 1N34 (Photo B) admirably fulfills these requirements. The cathode-to-anode capacitance of a unit mounted in place is of the order of 3  $\mu$ f. This is several times lower than the value of a conventional vacuum-tube diode when measured under similar conditions.

The type 1N34 is manufactured with pigtail leads and can therefore be readily soldered directly into the circuit. This economy of weight and size and the absence of any heater supply suggests their use in most portable and airborne equipment. The static characteristics of the type 1N34 are shown in Fig. 2. These characteristics may be utilized

for many applications. In addition to use as detectors, some other uses which suggest themselves are modulators of all descriptions, voltage regulators, low frequency oscillators, d.c. restorers and polarizing devices. In meter and instrument work they may be used as recti-

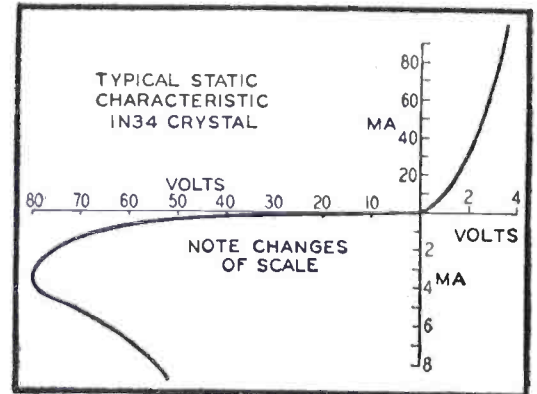

Fig. 2—Forward and reverse currents, 1N34.

fiers and in probes of vacuum tube voltmeters. In general, the type 1N34 is particularly useful with low impedance loads such as are exemplified by wide band television and FM circuits.

### EIGHTEEN TYPES LISTED

The table shows the principal characteristics of the most commonly used crystals. Although some eighteen types are listed by RMA and JAN specifications, many are already obsolete or have been made only in limited quantities for special applications. Those listed in the table are the types in most common demand today.

The crystal, for many years the plaything of boys building their first radio, has again come into its own. The increasing use of u.h.f. will cause it to grow further in importance.

TABLE I

### PROPERTIES OF CRYSTAL DIODES SILICON CRYSTAL CONVERTERS

Type/No.	Design Frequency <sup>1</sup>	Conversion <sup>2</sup> Loss	Output Noise Ratio <sup>3</sup>	Burnout Test <sup>4</sup>	I.F. Impedance (Resistive)
1N21B	3,000 Mc.	6.5 db max.	2.0 max.	$B_p=2.0$ ergs	200—800 ohms
1N23B	10,000 Mc.	6.5 db max.	2.7 max.	$B_p=1.0$ erg	150—600
1N25	1,000 Mc.	8.5 db max.	2.5 max.	$B_p=30$ watts	100—400
1N26	25,000 Mc.	8.5 db max.	2.5 max.	$B_p=0.1$ erg	300—600

### SILICON VIDEO DETECTOR CRYSTALS

Type No.	Figure of Merit <sup>5</sup>	Video Impedance	Burnout Test <sup>4</sup>	Carrier Freq.	Video Freq.
1N31	55 min.	6,000—24,000 ohms	$B_p=0.02$ w.	10,000 Mc.	500 cps—5 Mc.
1N32	100 min.	5,000—20,000 ohms	$B_p=0.36$ w.	3,000 Mc.	500 cps—5 Mc.

### GERMANIUM CRYSTAL DIODES

Type No.	Peak Inverse Anode voltage	Average Anode current	Peak Anode current (AC)	Transient Surge current	Design Frequency
1N34	50 volts max.	0-22.5 ma.	60 ma. max.	200 ma. max.	500 Mc. max.

- 1—Data indicate centers of frequency bands; in properly designed circuits may be used at lower frequencies.
- 2—I.F. output power compared to R.F. input power under standard conditions.
- 3—Noise (power) under standard conditions referred to the thermal or Johnson noise developed by an equivalent resistance.
- 4— $B_p$ =total energy in simulated spike of pulse from TR box.  
 $B_p$ =peak pulse power under pulsed conditions.
- 5—Figure of merit is a measure of the effectiveness of a video crystal as the detector preceding a video amplifier.



## DECIBEL PROBLEMS

(Continued from page 400)

formula for voltage ratios: Voltage Level =  $20 \log E/1.73$ .

Voltage level is not necessarily power level because the resistance across which the voltage is measured is not taken into account in the above formula. Only by knowing the resistance may power be computed from voltage, that is, 1.73 volts may represent .6, .06, or .006 watts if the resistance is 5, 50, or 500 ohms respectively, and although the voltage level is zero db, in each case, the power level is -20, -10, or zero db in the cases cited.

Voltage level is of great practical importance in measurement of electrical levels with the volume indicator. If this instrument were a wattmeter, we need not have troubled ourselves with the new term "voltage level." Actually it is a voltmeter, and 1.73 volts will deflect the needle to the part of the scale corresponding to 1.73 volts regardless of whether this voltage was measured across 5, 50, or 500 ohms. The meter scale would not show 1.73 volts in this case, but "0," since the standard output meter reads *directly* in db voltage level and the zero reference for voltage level is 1.73 volts. If the voltage is doubled, the power for the same resistance (whatever it may be), increases by a factor of 4 (6 db). The voltage level also by the same formula increases 6 db so that the needle moves to the part of the scale corresponding to 3.46 volts and this is marked 6 db. This meter could properly be called "Voltage Level Indicator."

Our readings are in *voltage level*, and many of our calculations are likewise on this basis, but sooner or later we are usually required to reduce the voltage levels to power levels. If the resistance or impedance is 500 ohms, the voltage levels are the same as the power levels since 500 ohms was taken as the "reference" impedance. (Strictly speaking, it is resistance that must be used for calculating power from voltage. The term "impedance" for a.c. resistance has become common usage, but it is sometimes important to remember, where reactance is involved, that true power must be calculated from resistance only.)

We have seen that if the impedance is 50 ohms the power level is 10 db greater than the voltage level, and if 5 ohms, 20 db greater. The correction factor for impedance may be calculated from:

Power Level to Voltage Level =  $10 \log 500/Z = \text{db}$ ; or Volume Indicator. Correction for Impedance =  $10 \log 500/Z = \text{db}$ .

This correction is added algebraically to the V. I. reading.

### HOW TO MAKE DB TABLES

DB	Power Ratio
1	1.25
2	1.5
3	2.0

Memorize the above. Proceed by ap-

plying the rule that to add 3 db, multiply the power ratio by 2.

Examples DB	Power Ratio
4=3+1	2x1.25=2.5
8=3+3+2	2x2x1.5=6.0

For more than 10 db or less than 0 db, move the decimal point. Examples:

DB	Power Ratio
15=10+3+2	10x2x1.5=30
21=20+1	100x1.25=125
37=30+3+3+1	1000x2x2x1.25=5000
-4=-3-1	.5x1/1.25=1/2.5
-18=-10-3-3-2	.1x.5x.5x1/1.5=1/60

For voltage or current ratios, divide the decibels by 2 and proceed as above for power ratios. Examples:

DB	Power Ratio
24/2=12=10+2	10x1.5=15
8/2=4=3+1	2x1.25=2.5

Errors are insignificant in the above except when the ratio of 1.5 for 2 db is used. In these cases an error of .02% is made, the true ratio being higher than that given (1.26x1.26).

For fractions of decibels find the ratio from: Power Ratio =  $\frac{1}{\text{DB}/4}$

### A BRIEF SUMMARY

THE DECIBEL is a method of expressing power ratios. It is used primarily as a matter of convenience.

A LOGARITHM is an exponent of 10. The log of a number is the power (exponent) to which 10 must be raised to equal the number. If  $n = \log x$ , then  $10^n = x$ .

DECIBELS are of the same nature as logarithms and are expressed in terms of logs to permit the use of log tables for their calculations. Db power ratio =  $10 \log W_2/W_1$ . If W watts is increased by Y db, then W is multiplied by the ratio corresponding to Y db. If W is decreased by Y db, then W is divided by the ratio corresponding to Y db. Decibels are positive for ratios greater than 1, and negative for ratios less than 1, and zero for a ratio of exactly 1.

POWER LEVEL is a means of expressing any value of power in decibels by comparing it to a reference value of power. The reference value is .006 watt. Power level is computed from the following: Power Level =  $10 \log W/.006 = \text{db}$ . Decibels corresponding to a voltage or current ratio are *twice* as great as for a power ratio of equal value. This results from the fact that power is proportional to the square of the voltage or the current. To convert voltage or current ratios to Decibels use these formulas: DB Voltage Ratio =  $20 \log E_2/E_1$ ; DB Current Ratio =  $20 \log I_2/I_1$ .

VOLTAGE LEVEL is a means of expressing any value of voltage in decibels by comparing it to a reference value of 1.73 volts. It is computed from: Voltage Level =  $20 \log E/1.73 = \text{db}$ . The V. I. meter reads directly in terms of

(Continued on following page)

## FOR EVERYTHING IN RADIO

WRITE

# Leo, W9GFQ

## For Fast Delivery!



Get Leo's own personal, sudden service on your radio and electronic needs. Quick delivery, low terms, liberal trade-in allowances.

### SERVICE DEALER NEEDS



#### WRL MULTITESTER

Steel case with 30-60% angle. Cat. No. 16-491. Less Leads .. **\$1875**

Handles AC DC Voltmeter, DO Millammeter, high and low range Ohmmeter. 3" meter with sturdy D'Aronsva movement. Size 5 1/2 x 8 x 3 1/4.

A complete stock of tools, replacement parts, test equipment, intercom and public address systems . . . everything for the progressive service dealer.

### FOR EXPERIMENTERS

#### PHONO AMPLIFIER KITS



Complete with tubes, speaker, stamped chassis, and all resistors and condensers.

Cat. No. 7-271 . . . . . \$9.50 ea. Lots of 3, ea. **\$915**

Crystal sets, Antenna Kits, Code Oscillator Kits, Transmitter Kits, and many other items for the experimenter and radio enthusiast.

### HAM NEEDS

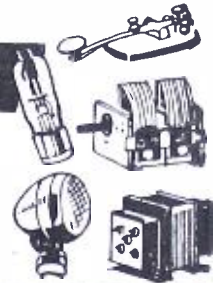

Transmitting tubes, condensers, mikes . . . everything for the Ham. One of the country's largest stocks of Ham equipment. Write Leo, W9GFQ, today, and be first with the latest. We invite inquiries for special equipment of all kinds.

### TRANSMITTERS

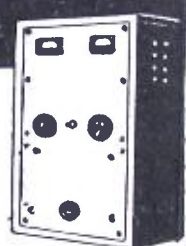

For peak performance and more dollar for dollar value, get a WRL Transmitter Kit . . . designed in Leo's own laboratories . . . tested and proven. Available in 15, 35, 70, and 150 watt kits as well as kits custom built to your own specs. Write Leo today for complete details, prices and terms.

### RECEIVERS



Here are just a few of the many well-known receivers offered by Leo:

- Hallicrafters SX-25 . . . . . \$ 94.50
- Hallicrafters S-20R . . . . . \$ 60.00
- Hallicrafters SX-28A . . . . . \$223.00
- Echophone EC-1A . . . . . \$ 29.50
- Hammarlund HQ-129X . . . . . \$129.00
- National NC-2-40C . . . . . \$225.00

Write for details of our trade-in plan and easy terms



#### NEW POST WAR 52 PAGE FLYER

52 pages packed with real buys in radio, electronic, and general merchandise. Write for your free copy today.

Send for these exclusive items:

- Tube and Circuit Book . . . . . 10¢
- Giant Radio Reference Map (size 3 1/2 x 4 1/2) . . . . . 15¢
- Gandy Tube-Base Calculator . . . . . 25¢

Address Dept. RC-3  
Council Bluffs, Iowa

*Wholesale*  
**RADIO LABORATORIES**



# RADOLEK

## Radio-Electronic Service Parts

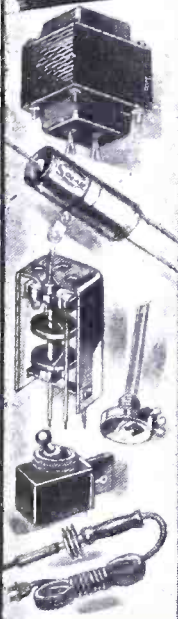

Large stocks assure the finest and most complete selections of all available items at lowest prevailing prices. Thousands of active buyers depend on us for their entire Radio repair and replacement requirements. Because we understand service problems, every order is expedited for delivery in double quick time. Everything we do is planned for convenience and satisfaction to our customers. You will find it profitable to make Radolek your buying headquarters.

### FREE BUYING GUIDES

Because of existing conditions we keep our customers right up to the minute on available merchandise by releasing supplements frequently instead of sending our regular

Big Profit Guide once a year. Send the coupon now to get these Free Buying Guide Supplements as they are issued.

**FREE!**



### FAST SERVICE!

RADOLEK CO., Dept. C-112  
601 W. Randolph St., Chicago 6, Ill.

Please send FREE Buying Guide Supplements

NAME \_\_\_\_\_  
ADDRESS \_\_\_\_\_

### ORDER FROM RADOLEK

## Immediate Delivery! SIGNAL CORPS TELEGRAPH KEY



Genuine U. S. Signal Corps key with switch to close contacts, polished durable enameled metal base mounted on a bakelite Special base, key lever is nickel-plated brass-silver contacts; packed in new, original boxes. Shipping weight, 1 lb. **95¢**  
10 for \$9.25

Shure Bros. single button hand carbon microphone. Push to talk switch, Army signal Corps type. Gov't cost \$5.85.

**Special \$2.49**

5-watt wire wound Resistors all ohms  
8c each

10-watt wire wound Resistors all ohms  
12c each

Wire wound Resistors 5 W. to 400 W., all sizes. Special Low Prices.

RCA 8" Magnetic Speaker mounted on beautiful walnut baffle, with separate volume control and interstation switch controls. Ideal for inter-comm. or speaker extension work.

**Special \$2.95**

G.E. 3" square 0-15 M.A. meters.

**List \$9.00, Special \$3.49**

On all above specials, we guarantee 24 hour mail order service. Write us for our latest Manhattan Catalog.

## MANHATTAN RADIO PARTS CO.

243 Broadway, N. Y. 7, N. Y.

## DECIBEL PROBLEMS

(Continued from previous page)

voltage level.  $Voltage\ Level = Power\ Level\ only\ for\ 500\ ohms\ resistance.$

For lines of other resistance or impedance, voltage level may be changed to power level by adding a value computed by the formula:  $V. I. Correction\ Factor\ for\ Impedance = 500/Z.$

From the previous discussion it can be seen that formulae relating to power ratios or sound changes need not be complicated beyond comprehension. It is hoped that this attempt by the author toward simplification may help in gaining an easier insight to the practical side of sound work.

Material used in this paper was taken from notes extending over a period of several years and condensed from well-known power formulae.

## RADIO SIGNALS

(Continued from page 383)

neer before the war, admits having made attempts to radio the moon as an amateur experimenter in 1940. A true ham, he is still not entirely satisfied with the greatest DX ever attained by one of the fraternity, and is already looking forward to working the moon on 'phone! Army scientists, he said, hope to increase their transmitter's power so that it could be modulated by voice. "We should like to be able to say 'Hello' and hear the moon say 'Hello' back. . . . I hope the moon doesn't answer, 'Good-by,'" he declared.

## WRECKING PROTESTED

Wrecking of Japanese cyclotrons by Army authorities was protested by the Association of Oak Ridge Scientists, comprising most of the men who developed the atomic bomb. Branding act as "wanton and stupid" they pointed out that a cyclotron is an instrument of research and can in no way be useful in the production of bombs. They demanded that officials responsible for "the act of pillage" be disciplined. "Men who cannot distinguish between the usefulness of the research machine and the military importance of a 16-inch gun have no place in positions of authority," the statement concluded.

## CASH FOR SERVICE SHOP PHOTOS

Radio-Craft wishes to obtain photographs of good Service Shops. Send us a photo of your shop, together with a description to help us evaluate the picture. We will pay three dollars for each excellent snapshot, and five dollars for each professional photograph accepted. Photos not accepted will be returned at once.

VELOCITY

P.G. DYNAMIC

**THE FINEST MICROPHONES**

# AMPERITE

**FOR PUBLIC ADDRESS & RECORDING**

**MICROPHONES THAT SURPASS THE HIGHEST REQUIREMENTS OF BROADCASTING, PUBLIC ADDRESS, AND RECORDING**

**KONTAK MIKES**

Write for Catalog

**AMPERITE COMPANY**  
561 BROADWAY NEW YORK, N. Y.

## HAZELTON INSTRUMENT CO.

Electric Meter Laboratory

Electrical instruments, Tube Checkers, and Analyzers repaired.

140 Liberty St., New York, N.Y.

Tel. BARclay 7-4239

**BUILD YOUR OWN FAST FREEZER** PLANS \$1.00

It's easy to build this household appliance and profitable to use. Save up to 75%. Operates on 110 or 32 volts. Plans show 5 sizes and are easy to follow. **ENJOY MAKING ONE OF these freezers from new or used parts. No expert knowledge needed. Mail \$1.00 bill or check for complete plans and catalog.**

**LE JAY MFG. CO.,** 356 LeJay Bldg., Minneapolis 8, Minn.

5 sizes 8 to 40 cu. ft.

## NO 540-KC BROADCASTS

Broadcasting on 540 kc will have to wait till the next International Telecommunications Conference, the FCC announced last month. At the same time it was announced that wartime power-output restrictions on 550 and 560 kc had been lifted. Actually, however, broadcast stations on those frequencies have been permitted to use normal power since late last fall.

In connection with the use of frequencies below 550 kc, the Commission pointed out that, in addition to the International Conference angle, the FCC rules "do not provide for the use of 540 kc by standard broadcast stations."

It was estimated that the 540 kc channel will not be available to the U. S. for at least two years.



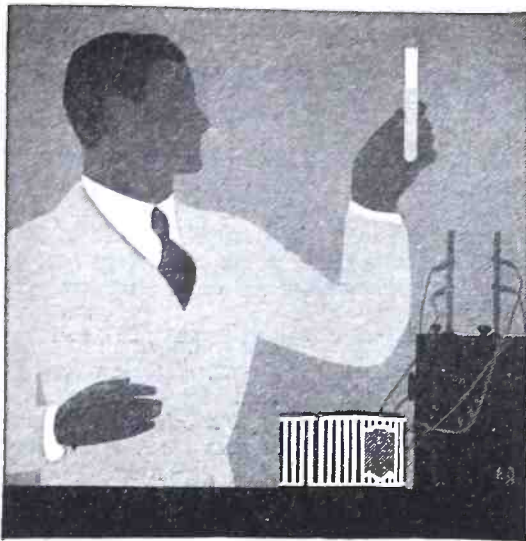

## WORLD-WIDE STATION LIST

(Continued from page 402)

to 10 a.m.; 12:45 to 1:45 p.m.; OLR4A on 11.840 megacycles at 3:45 to 4 a.m.; and 5 to 5:30 a.m.

Rangoon, Burma, is heard best at 5:45 to 7:15 a.m. on 6.035 megacycles. It is heard quite often on the east coast. Copenhagen Denmark, is heard now at 11:30 a.m. to 3 p.m. on the following frequencies; OZU, 7.260; OZF, 9.520; and OZH, 15.320 megacycles.

This month we are presenting another graph of the best heard stations, other than the U. S. and Canada; but the time has been changed to cover from 9 p.m. to 5 a.m. A short time ago, we heard that they have a different time belt on the west coast, and that our former graph was no good to them after 9 p.m.; so we made up a new one to take care of their needs. Many thanks to those who wrote to me about this. Constructive criticism is what we need. So long till next month, and best of dx.

All schedules are Eastern Standard Time.

The closing date of the First Annual All-Amateur Transmitting Contest has been postponed to March 15, 1946. Illness of one of the judges made this one-month extension of the closing date necessary. As announced in this magazine (December, 1945, page 216) two complete transmitters are to be given away as prizes. To enter the contest, the amateur need only draw a diagram and submit a complete description of the transmitter he would like to have.

## RADIO-ELECTRONIC QUIZ

How thoroughly have you mastered the contents of this magazine? Try the following quiz as a test:

1. What is an "electronic" hot dog? (See page 382.)
2. Why must the pulse repetition frequency in pulse modulation be at least double the highest modulating frequency? (See page 385.)
3. How can a blind man read a multi-tester? (See page 387.)
4. What type of timepiece is meant by a "repeater"? (See page 389.)
5. Under what circumstances should tuned r.f. and i.f. stages be provided in a signal tracer? (See page 393.)
6. What is meant by "below ground" limiting? (See page 396.)
7. What is the common zero reference level in calculating decibels? (See page 400.)
8. Why is peacetime radar likely to be cheaper than the military variety? (See page 408.)
9. What was the FCC called "before it was FCC"? (See page 413.)
10. Of what use is a microammeter in servicing an FM receiver? (See page 443.)

## SENSATIONAL SPECIALS

ON

## POPULAR MERCHANDISE

A FEW OF OUR TYPICAL BARGAINS!

BALLAST TUBES, ANY TYPE—\$.39 ea.

RELAYS—D.P.D.T.—Heavy duty construction, coil resistance—50 ohms, suitable for operation in tube plate circuit—\$1.50. Send for our free relay sheet for full description of our stock of relays.

TUBULAR CONDENSERS—Guaranteed one year. Prices in lots of ten, either one type or assorted. 100 Mf, 25V—\$.35; 50 Mf, 150V—\$.45; 20-50 Mf, 150V—40; 20-20 Mf, 150V—30; 25 Mf, 25V—20; 10-10 Mf, 450V—45; 20 Mf, 150V—20; 16 Mf, 450V—40; 12 Mf, 150V—15; 10 Mf, 450V—27; 10 Mf, 50V—15; 8 Mf, 450V—23; Paper condensers, 600V: .25 Mf—20; .1 Mf—10; .05 Mf—09; .02 Mf—08; .01 Mf—08; .008 Mf—05; .005 Mf and smaller—.07. MICA condensers, 1000V test, 600 WV, any standard capacity—\$.15. SPECIAL—100 assorted new but outdated condensers, no guarantee—.90. Average weight—25 lbs.

30 Watt Army Transceivers, complete with 15 tubes, less power supply—\$39.95. Midget circuit breakers, made for military use, 20 amp.—1.25 ea. Heavy duty solid brass, screw type binding posts, .03 ea. 7 assorted IF transformers in aluminum cans—1.98; 5 assorted oscillator coils—.69; Test leads and prods, needle type, 50" wires, 5KV insulation—.50 per pair.

POWER TRANSFORMERS, half-shell type, 110V 60 Cycle. Specify either 6.3 or 2.5V when ordering. For 4-5 tube sets—650V, 40MA CT-5V fl. and either 6.3 2.5V fl. ....\$1.40

For 5-6 tube sets—650V, 45 MA CT-5V fl. and either 6.3 2.5V fl. ....\$1.55

For 6-7 tube sets—675V, 50MA CT-5V fl. and either 6.3 2.5V fl. ....\$1.70

For 7-8 tube sets—700V, 70MA CT-5V fl. and either 6.3 two 2.5 fls. ....\$2.05

For 9-11 tube sets—700V, 100MA CT-5V fl. and either 6.3 two 2.5V fls. ....\$2.75

FILTER CHOKES—2" mounting; Cadmium plated straps—200, 300, 400 or 500 ohms—Heavy Duty—.89; Midget type—.49. AUDIO TRANSFORMERS—

1 plate to single grid, 3:1—.69; 1 plate to PP grids—.69; Universal output, tapped for various impedances—.79; Mike transformers, single or double button—.69.

MICROPHONES—Gold-plated single button midget carbon mike—waterproof and rugged—built for Signal Corps. May be used as lapel mike, concealed or secret pickups, for amplifiers, or may be attached to a home radio. SUPER SPECIAL—.95 ea. Bullet Crystal Mikes—\$.45; Bullet Dynamic Mikes—7.45.

100 Watt resistors: 100, 250, 3M, 10M, 11M, 20M ohms—.35 ea. 10 Watt, 1-10 ohm—.10 ea. 300, 1M, 12M ohms—.15 ea. 20 Watt: 18 ohm—.10. 50 Watt: 15M ohm—.35 ea. 80 ohm, non-inductive—.10 ea. 250 ohm CT—.20 ea. All are IRC, Ohmite, Ward-Leonard or equivalent.

3-Section auto antennas, complete with leads; 66"—1.50; 96"—2.95. High-grade Shure crystal pickups—3.75; Male AC plugs: Bakelite—\$.20 per 100; Heavy Rubber—5.95 per 100. Bakelite Cube taps—1.00 per doz.

3-Section auto antennas, complete with leads; 66"—1.50; 96"—2.95. High-grade Shure crystal pickups—3.75; Male AC plugs: Bakelite—\$.20 per 100; Heavy Rubber—5.95 per 100. Bakelite Cube taps—1.00 per doz.

3-Section auto antennas, complete with leads; 66"—1.50; 96"—2.95. High-grade Shure crystal pickups—3.75; Male AC plugs: Bakelite—\$.20 per 100; Heavy Rubber—5.95 per 100. Bakelite Cube taps—1.00 per doz.

3-Section auto antennas, complete with leads; 66"—1.50; 96"—2.95. High-grade Shure crystal pickups—3.75; Male AC plugs: Bakelite—\$.20 per 100; Heavy Rubber—5.95 per 100. Bakelite Cube taps—1.00 per doz.

3-Section auto antennas, complete with leads; 66"—1.50; 96"—2.95. High-grade Shure crystal pickups—3.75; Male AC plugs: Bakelite—\$.20 per 100; Heavy Rubber—5.95 per 100. Bakelite Cube taps—1.00 per doz.

3-Section auto antennas, complete with leads; 66"—1.50; 96"—2.95. High-grade Shure crystal pickups—3.75; Male AC plugs: Bakelite—\$.20 per 100; Heavy Rubber—5.95 per 100. Bakelite Cube taps—1.00 per doz.

3-Section auto antennas, complete with leads; 66"—1.50; 96"—2.95. High-grade Shure crystal pickups—3.75; Male AC plugs: Bakelite—\$.20 per 100; Heavy Rubber—5.95 per 100. Bakelite Cube taps—1.00 per doz.

3-Section auto antennas, complete with leads; 66"—1.50; 96"—2.95. High-grade Shure crystal pickups—3.75; Male AC plugs: Bakelite—\$.20 per 100; Heavy Rubber—5.95 per 100. Bakelite Cube taps—1.00 per doz.

3-Section auto antennas, complete with leads; 66"—1.50; 96"—2.95. High-grade Shure crystal pickups—3.75; Male AC plugs: Bakelite—\$.20 per 100; Heavy Rubber—5.95 per 100. Bakelite Cube taps—1.00 per doz.

3-Section auto antennas, complete with leads; 66"—1.50; 96"—2.95. High-grade Shure crystal pickups—3.75; Male AC plugs: Bakelite—\$.20 per 100; Heavy Rubber—5.95 per 100. Bakelite Cube taps—1.00 per doz.

3-Section auto antennas, complete with leads; 66"—1.50; 96"—2.95. High-grade Shure crystal pickups—3.75; Male AC plugs: Bakelite—\$.20 per 100; Heavy Rubber—5.95 per 100. Bakelite Cube taps—1.00 per doz.

3-Section auto antennas, complete with leads; 66"—1.50; 96"—2.95. High-grade Shure crystal pickups—3.75; Male AC plugs: Bakelite—\$.20 per 100; Heavy Rubber—5.95 per 100. Bakelite Cube taps—1.00 per doz.

3-Section auto antennas, complete with leads; 66"—1.50; 96"—2.95. High-grade Shure crystal pickups—3.75; Male AC plugs: Bakelite—\$.20 per 100; Heavy Rubber—5.95 per 100. Bakelite Cube taps—1.00 per doz.

3-Section auto antennas, complete with leads; 66"—1.50; 96"—2.95. High-grade Shure crystal pickups—3.75; Male AC plugs: Bakelite—\$.20 per 100; Heavy Rubber—5.95 per 100. Bakelite Cube taps—1.00 per doz.

3-Section auto antennas, complete with leads; 66"—1.50; 96"—2.95. High-grade Shure crystal pickups—3.75; Male AC plugs: Bakelite—\$.20 per 100; Heavy Rubber—5.95 per 100. Bakelite Cube taps—1.00 per doz.

3-Section auto antennas, complete with leads; 66"—1.50; 96"—2.95. High-grade Shure crystal pickups—3.75; Male AC plugs: Bakelite—\$.20 per 100; Heavy Rubber—5.95 per 100. Bakelite Cube taps—1.00 per doz.

3-Section auto antennas, complete with leads; 66"—1.50; 96"—2.95. High-grade Shure crystal pickups—3.75; Male AC plugs: Bakelite—\$.20 per 100; Heavy Rubber—5.95 per 100. Bakelite Cube taps—1.00 per doz.

3-Section auto antennas, complete with leads; 66"—1.50; 96"—2.95. High-grade Shure crystal pickups—3.75; Male AC plugs: Bakelite—\$.20 per 100; Heavy Rubber—5.95 per 100. Bakelite Cube taps—1.00 per doz.

3-Section auto antennas, complete with leads; 66"—1.50; 96"—2.95. High-grade Shure crystal pickups—3.75; Male AC plugs: Bakelite—\$.20 per 100; Heavy Rubber—5.95 per 100. Bakelite Cube taps—1.00 per doz.

3-Section auto antennas, complete with leads; 66"—1.50; 96"—2.95. High-grade Shure crystal pickups—3.75; Male AC plugs: Bakelite—\$.20 per 100; Heavy Rubber—5.95 per 100. Bakelite Cube taps—1.00 per doz.

3-Section auto antennas, complete with leads; 66"—1.50; 96"—2.95. High-grade Shure crystal pickups—3.75; Male AC plugs: Bakelite—\$.20 per 100; Heavy Rubber—5.95 per 100. Bakelite Cube taps—1.00 per doz.

3-Section auto antennas, complete with leads; 66"—1.50; 96"—2.95. High-grade Shure crystal pickups—3.75; Male AC plugs: Bakelite—\$.20 per 100; Heavy Rubber—5.95 per 100. Bakelite Cube taps—1.00 per doz.

3-Section auto antennas, complete with leads; 66"—1.50; 96"—2.95. High-grade Shure crystal pickups—3.75; Male AC plugs: Bakelite—\$.20 per 100; Heavy Rubber—5.95 per 100. Bakelite Cube taps—1.00 per doz.

3-Section auto antennas, complete with leads; 66"—1.50; 96"—2.95. High-grade Shure crystal pickups—3.75; Male AC plugs: Bakelite—\$.20 per 100; Heavy Rubber—5.95 per 100. Bakelite Cube taps—1.00 per doz.

3-Section auto antennas, complete with leads; 66"—1.50; 96"—2.95. High-grade Shure crystal pickups—3.75; Male AC plugs: Bakelite—\$.20 per 100; Heavy Rubber—5.95 per 100. Bakelite Cube taps—1.00 per doz.

3-Section auto antennas, complete with leads; 66"—1.50; 96"—2.95. High-grade Shure crystal pickups—3.75; Male AC plugs: Bakelite—\$.20 per 100; Heavy Rubber—5.95 per 100. Bakelite Cube taps—1.00 per doz.

3-Section auto antennas, complete with leads; 66"—1.50; 96"—2.95. High-grade Shure crystal pickups—3.75; Male AC plugs: Bakelite—\$.20 per 100; Heavy Rubber—5.95 per 100. Bakelite Cube taps—1.00 per doz.

3-Section auto antennas, complete with leads; 66"—1.50; 96"—2.95. High-grade Shure crystal pickups—3.75; Male AC plugs: Bakelite—\$.20 per 100; Heavy Rubber—5.95 per 100. Bakelite Cube taps—1.00 per doz.

3-Section auto antennas, complete with leads; 66"—1.50; 96"—2.95. High-grade Shure crystal pickups—3.75; Male AC plugs: Bakelite—\$.20 per 100; Heavy Rubber—5.95 per 100. Bakelite Cube taps—1.00 per doz.

3-Section auto antennas, complete with leads; 66"—1.50; 96"—2.95. High-grade Shure crystal pickups—3.75; Male AC plugs: Bakelite—\$.20 per 100; Heavy Rubber—5.95 per 100. Bakelite Cube taps—1.00 per doz.

3-Section auto antennas, complete with leads; 66"—1.50; 96"—2.95. High-grade Shure crystal pickups—3.75; Male AC plugs: Bakelite—\$.20 per 100; Heavy Rubber—5.95 per 100. Bakelite Cube taps—1.00 per doz.

3-Section auto antennas, complete with leads; 66"—1.50; 96"—2.95. High-grade Shure crystal pickups—3.75; Male AC plugs: Bakelite—\$.20 per 100; Heavy Rubber—5.95 per 100. Bakelite Cube taps—1.00 per doz.

3-Section auto antennas, complete with leads; 66"—1.50; 96"—2.95. High-grade Shure crystal pickups—3.75; Male AC plugs: Bakelite—\$.20 per 100; Heavy Rubber—5.95 per 100. Bakelite Cube taps—1.00 per doz.

3-Section auto antennas, complete with leads; 66"—1.50; 96"—2.95. High-grade Shure crystal pickups—3.75; Male AC plugs: Bakelite—\$.20 per 100; Heavy Rubber—5.95 per 100. Bakelite Cube taps—1.00 per doz.

3-Section auto antennas, complete with leads; 66"—1.50; 96"—2.95. High-grade Shure crystal pickups—3.75; Male AC plugs: Bakelite—\$.20 per 100; Heavy Rubber—5.95 per 100. Bakelite Cube taps—1.00 per doz.

3-Section auto antennas, complete with leads; 66"—1.50; 96"—2.95. High-grade Shure crystal pickups—3.75; Male AC plugs: Bakelite—\$.20 per 100; Heavy Rubber—5.95 per 100. Bakelite Cube taps—1.00 per doz.

3-Section auto antennas, complete with leads; 66"—1.50; 96"—2.95. High-grade Shure crystal pickups—3.75; Male AC plugs: Bakelite—\$.20 per 100; Heavy Rubber—5.95 per 100. Bakelite Cube taps—1.00 per doz.

3-Section auto antennas, complete with leads; 66"—1.50; 96"—2.95. High-grade Shure crystal pickups—3.75; Male AC plugs: Bakelite—\$.20 per 100; Heavy Rubber—5.95 per 100. Bakelite Cube taps—1.00 per doz.

3-Section auto antennas, complete with leads; 66"—1.50; 96"—2.95. High-grade Shure crystal pickups—3.75; Male AC plugs: Bakelite—\$.20 per 100; Heavy Rubber—5.95 per 100. Bakelite Cube taps—1.00 per doz.

3-Section auto antennas, complete with leads; 66"—1.50; 96"—2.95. High-grade Shure crystal pickups—3.75; Male AC plugs: Bakelite—\$.20 per 100; Heavy Rubber—5.95 per 100. Bakelite Cube taps—1.00 per doz.

3-Section auto antennas, complete with leads; 66"—1.50; 96"—2.95. High-grade Shure crystal pickups—3.75; Male AC plugs: Bakelite—\$.20 per 100; Heavy Rubber—5.95 per 100. Bakelite Cube taps—1.00 per doz.

3-Section auto antennas, complete with leads; 66"—1.50; 96"—2.95. High-grade Shure crystal pickups—3.75; Male AC plugs: Bakelite—\$.20 per 100; Heavy Rubber—5.95 per 100. Bakelite Cube taps—1.00 per doz.

## LAKE'S RADIO Cabinets & Parts

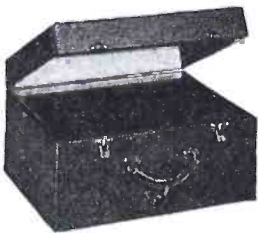

Portable Phonograph case, of sturdy durable plywood, in handsome brown leatherette finish. Inside dimensions 16 1/2" long, 14" wide, 9 1/2" high. Has blank motor board. As illustrated above specially priced **\$6.95** at .....

### NOW AVAILABLE!

#### Postwar 2 Post RECORD-CHANGER

In luxurious brown leatherette portable case. 15" L x 15" W x 10" D. Latest electronic developments make this modern record-changer the finest one on the market today! List price...\$49.95 Dealers' Net...\$29.97

Also blank table cabinets of walnut veneer in the following sizes, with speaker opening on left front side. (Note: 7" has center speaker grill.)

#1	8 1/4"	L x	5 1/2"	H x	4"	D	\$1.95
#2	10 1/4"	L x	6 3/8"	H x	5"	D	\$2.75
#3	13 1/2"	L x	7 5/8"	H x	6 1/2"	D	\$3.25
#7	10 3/4"	L x	7"	H x	5 1/2"	D	\$2.50
#8	17"	L x	9"	H x	9 3/4"	D	\$4.50
#9	21"	L x	9 1/4"	H x	10 1/2"	D	\$5.50

\*Speaker Opening in center of front side. Cabinets available in ivory color and Swedish Modern. Write for prices.

All types of radio cabinets and parts are available at Lake's lower prices. A large stock is listed in our catalog.

SERVICEMEN—RETAILERS Join our customer list today.

Write for our NEW, 12 page, illustrated, elaborate catalog! Order from Lake! You'll make no mistake!

Dept. C



## LAKE RADIO SALES CO.

615 W. Randolph Street, Chicago 6, Ill.



**New Direct-Coupled FM - AM**

# AMPLIFIER MANUAL

**By A. C. SHANEY**

*Chief Engineer, Amplifier Co. of America*

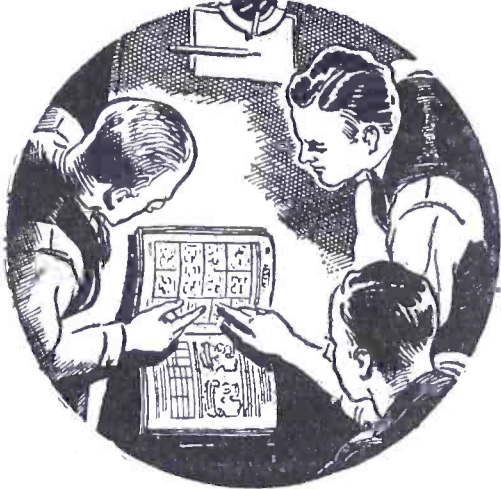

**For the Layman, Serviceman  
Recordist and Engineer**

Regardless of whether you are interested in the finest type of phonograph reproduction, high fidelity recording, sound-on-film applications, FM or AM programs, you will find invaluable information in this practical handbook. Written by the leading exponent of direct-coupled amplifiers who has spent more than 10 years improving and perfecting the famous Loftin-White circuit.

**Explains the theory and practical application of:**

- Variable Speed Non-Overloading Push-Pull Expansion
- Non-Frequency Discriminating Scratch Suppression
- Push-Pull Balanced Direct-Coupled Amplification
- Push-Pull High-Frequency Equalization
- Push-Pull Low-Frequency Equalization
- Push-Pull Volume Compression
- Automatic Volume Limitation
- Automatic Volume Control
- Calibrated V. U. Indicator
- Audio Spectrum Control
- Remote Control

If you are interested in the latest audio developments, you can't afford to be without this complete compilation of authentic articles on Direct-Coupled Amplifiers. 32 pages 8 1/2" x 11". Over 100 diagrams and illustrations.

Priced to Cover Cost of  
Printing and Mailing **25c**

Send U. S. Stamps or Coin

**AMPLIFIER CO. of AMERICA**

896 BROADWAY

NEW YORK, N. Y.

# WORLD'S BIGGEST BETATRON

**B**IGGEST of its kind is the 100,000,000 volt betatron or electron accelerator constructed at the General Electric Research Laboratory in Schenectady, N. Y.

The new machine gives out X-rays of a power never previously approached. These will penetrate a thickness of metal considerably greater than the rays from G-E's 2,000,000-volt industrial X-ray unit. But even more exciting are the possibilities that with the 100,000,000-volt electron stream that produces X-rays of the same energy we can produce other interesting forms of radiation.

Located in a special building with concrete walls three feet thick, as a protection from the dangerous rays given off, the principal part of the betatron is a huge electromagnet, made of 130 tons of laminated silicon steel. It is 9 feet high, 6 feet wide and 15 feet long. In a rectangular opening passing through the magnet from front to back are the pole faces, 76 inches in diameter, surrounded by large coils of insulated 1-inch copper conductor. As electricity at 24,000 volts surges through these coils from a bank of condensers in an upstairs room, the magnet is energized, the intense magnetic field being concentrated in the horizontal space between the pole faces.

Here is the heart of the machine—a doughnut-shaped vacuum tube of glass. The doughnut has an over-all diameter of 74 inches while the tube itself, of elliptical cross section, measures inside 8 inches horizontally and nearly 5 inches vertically. It is made of 16 sectors of molded and tempered pyrex glass, cemented together. The inner surface of this tube had to be made electrically conducting, so that it would not accumulate a charge that would upset the paths of the electrons within. This was accomplished by sandblasting the inner surfaces and then silvering them.

Projecting into the doughnut at one point is an electron gun, consisting of a heated filament from which electrons are boiled

off, to be given an initial impulse of several thousand volts to start them in their orbits inside the doughnut. The magnetic field holds them in a fixed circular orbit as they gain speed and energy on successive revolutions, gaining about 400 electron volts each trip.

The machine operates on ordinary 60-cycle alternating current. Acceleration of the electrons is confined to the first quarter of each cycle, lasting 1/240th of a second, during which the current goes from zero to its maximum in one direction. Then it goes back to zero, before building up in the opposite direction. If the electrons were allowed to remain in the tube during the second quarter cycle they would be slowed down again, so they are removed before this happens.

Just as the end of the quarter cycle is reached, a pulse of current passes through two smaller auxiliary coils on the pole faces. This causes the electrons to spiral away from their orbit and to hit a tungsten target which they previously missed. This causes the generation of X-rays, which emerge from the doughnut in a beam which is 2 degrees in diameter when the machine is operated at full power.

It may, however, be operated at a lower power, as the pulse may be applied at any time during the first quarter cycle. If, for example, it is done when they have made only 125,000 instead of the full 250,000 revolutions, they will have energies of only 50,000,000 electron volts. Or they may be taken out at any other stage so the device can produce X-rays from about 2,000,000 up to 100,000,000 volts. On one of the control panels is a unique instrument—a megavolt meter. A megavolt is a million volts, and the dial of this meter is graduated from one to 100 of these units. When the machine is operating at full power, this indicates 100,000,000 volts as casually as a small voltmeter might show 5 or 6 volts when used to test an automobile battery.

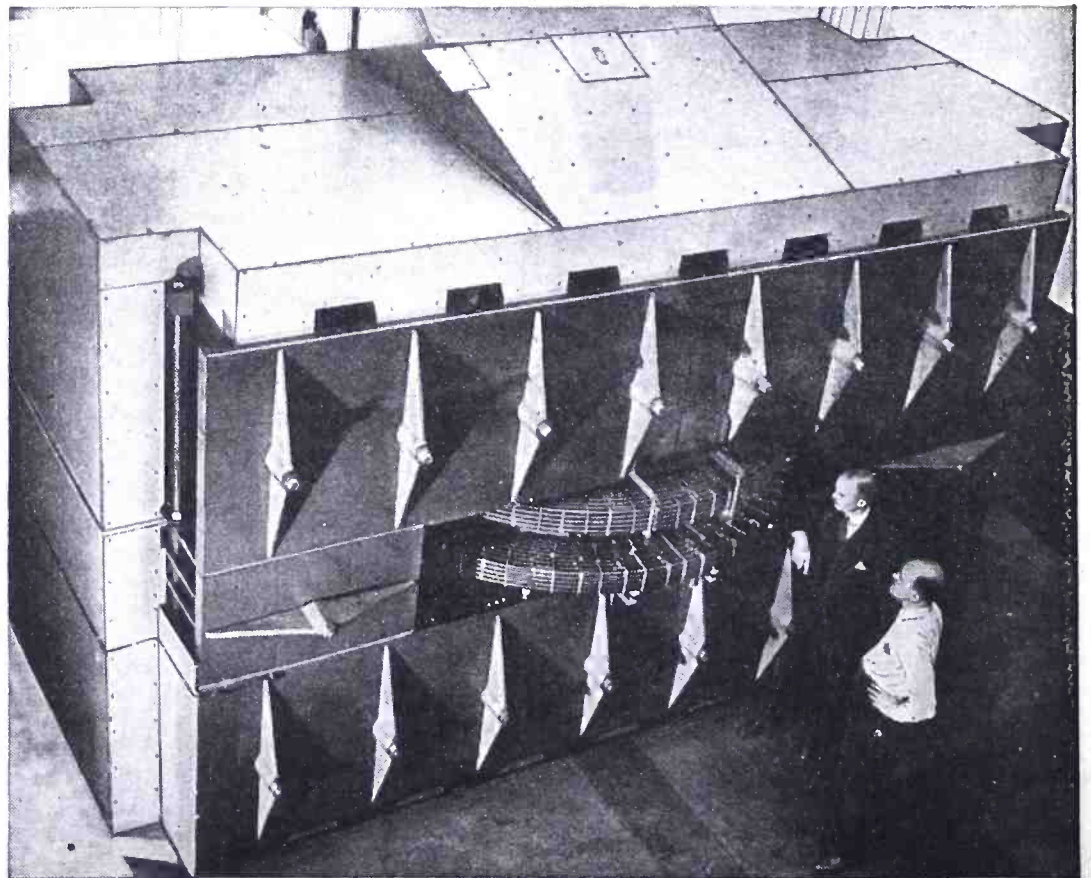

A view of the world-beating betatron. The giant magnet coils protrude slightly from the front.

## FREE

TO  
**RADIO  
MEN**

**COLOR CODE and  
OHMS LAW CALCULATOR**

Burstein-Applebee of Kansas City offers you this great convenience **FREE**. Easy to work. Solves many problems in a jiffy. **FREE** to radio men, electronic engineers and others in the business. Attach coupon to your letterhead.

**MAIL COUPON NOW**

**BURSTEIN-APPLEBEE CO.**  
1012 MCGEE, KANSAS CITY 6, MO.

Send me **FREE** Color Code and Ohms Law Calculator along with latest catalog.

I am \_\_\_\_\_  
STATE CONNECTION IN INDUSTRY

NAME \_\_\_\_\_

ADDRESS \_\_\_\_\_

TOWN \_\_\_\_\_ STATE \_\_\_\_\_



## ?? WHY NOT ??

Have you ever asked yourself, "Why can't I have this or that gadget on a radio? Why aren't programs made to fill such and such a need?" If so, you are a charter member of the *Radio-Craft* "Why Not" club. Send us your "Why Not's" on all subjects—serious or screwball, practical or idealistic. We will pay \$1.00 for every one we believe will interest the readers of *Radio-Craft*.

You can get the idea from the "Why Not's" printed below. Send in as many as you like. One dollar will be paid for each one printed.

Why not have a system on the home telephone similar to that used by inter-communicators, so that when the telephone rings you won't have to be bothered with a handset?

The only control necessary would be a talk-listen switch; or a separate mike and speaker could be employed in case the little woman would like to use "break-in" and not let the other party talk all the time.

JAMES H. MAULDIN,  
Ardmore, Okla.

Why not put an extra foot of wire or standardized plugs on the speaker leads to facilitate testing a set with its own speaker?

B. BUEHRLE, JR.,  
Ferguson 21, Mo.

Why not manufacture radio sets with a removable speaker or with leads of sufficient length so that it can be carried about from room to room when desired without having to move the entire radio? This would be appreciated by persons who are unable to own more than one radio.

SGT. JOHN HENDERSON,  
Fort Bragg, N. Carolina

Why not provide a cord and plug on the loop antennas that form the back of portable receivers so that they can be removed without tearing the wires loose?

JOHN M. HICKS, AETM 1/c,  
Banana River, Fla.

Why not have the tube manufacturers design a complete line of 117-volt tubes? This would eliminate ballasts and line cords. To date, the only 117-volt tubes to my knowledge are a rectifier and rectifier-beam power amplifier combinations.

NICK BOCKER,  
Brandon, Manitoba

## speco PLASTIC PLIERS



\$1.00

- Weighs 1 1/2 ounces!
- Absolutely shock-proof non-magnetic!
- 6,000 volt breakdown!
- Heat resistance 240 to 300 degrees!
- Tensile strength of material, 5000 lbs. per square inch!
- Pick up nuts, screws and washers without danger of shorting!
- Relocate wiring without disturbing magnetic fields while equipment is operating!

DEPT. 7-3

ROBERTS ASSOCIATES, P. O. BOX 622, G. C. ANNEX, N. Y. 17

# NEW and ALLIED'S 1946 Ready for you! CATALOG



of Radio and  
Electronic Supplies

FREE

Send for it Now!

### LARGEST AND MOST COMPLETE STOCKS

Today's handiest, most complete *Buying Guide!* Brings you latest, finest values in parts, tubes, kits, tools, books, test instruments, communications receivers, Ham gear, public address and other equipment. Places at your finger tips over 10,000 items of nationally known guaranteed quality. Makes available to you the world's largest and most complete stocks under one roof . . . ready for rush delivery. Enables you to get everything you need in radio and electronics from one dependable, central source. Send for this new 1946 Catalog now. Save time, work and money!

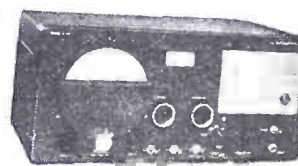

### NEW RADIO SETS

Parade of new 1946 models, including phonoradios, and latest communications receivers covering broadcast, short-wave and amateur bands. Beautiful styles! Wonderful performance! Outstanding values!



### HANDY RADIO BOOKS

Specially prepared by Technical experts for radio training and for helpful reference.

Radio Formulas & Data, Dictionary of Radio Terms, Radio Circuit Handbook, Radio Builders' Handbook, Simplified Radio Servicing, Radio Data Handbook—Six Books No. 37-799, 75c.

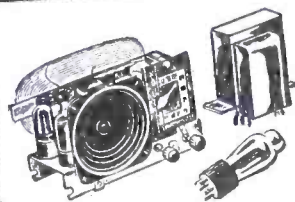

### OVER 10,000 ITEMS

Biggest section of quality parts and equipment for engineers, dealers, servicemen, soundmen, amateurs, builders. All leading makes, at lowest prices. Send for Free Catalog now.

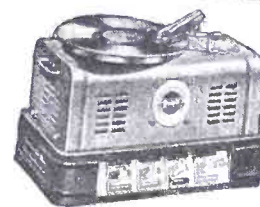

### NEW P. A. EQUIPMENT

Sound systems for every public address requirement. Complete listing of amplifiers, speakers, microphones, accessories. Newest developments with many exclusive features.

ALLIED RADIO CORP.  
833 W. Jackson Blvd., Dept. 2-CC-6  
Chicago 7, Illinois

Date.....

- Send FREE New 1946 Catalog.  
 Send Six Books No. 37-799 (75c enclosed)

Name.....

Address.....

City.....Zone.....State.....

# ALLIED RADIO

Everything in Radio  
and Electronics



# ALLEN Key Kits

Key Assortments to fit Hex-Socket Screws in the range of sizes the radio mechanic needs for everyday work.

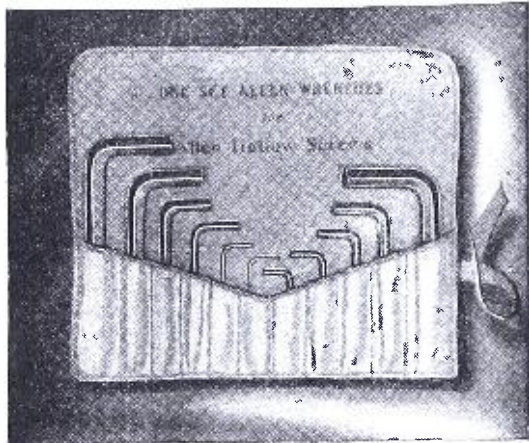

**KEY SET No. 603:** This canvas partitioned bag contains 11 short arm hexagonal keys which fit all screws from and including No. 10 up to and including 1/4" diameter set screws. List price \$1.75.

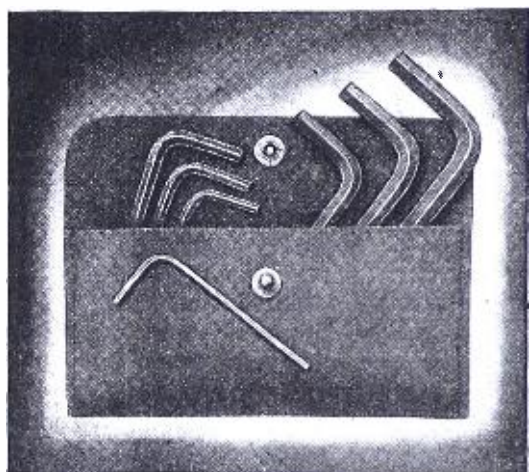

**JUNIOR KEY KIT No. 604:** Seven short-arm Allen Keys are included in this strong leatherette envelope. They fit the hex holes of sizes Nos. 8, 10, 1/4", 5/16", 3/8", 7/16" and 1/2" set screws and Nos. 4, 5, 6, 8, 10, also 1/4" and 5/16" cap screws. List price \$0.50.

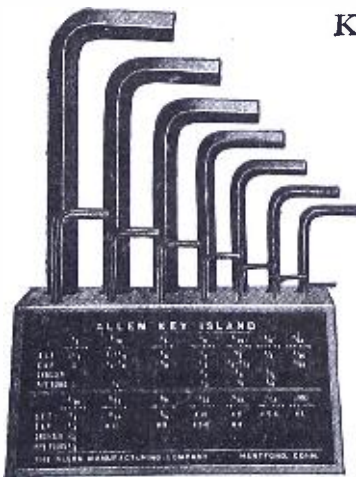

## KEY ISLAND

This handy key set contains 14 keys fitting all sizes of set screws up to and including 1/4"; cap screws up to 1"; shoulder screws to 1" and pipe plugs to 1". Container is plainly labeled to show the correct size key to use with each screw. No. 615; list price \$2.35.

Ask for complete listings of Allen Hollow Screw Assortments and Key Kits. Address inquiries and orders to Dep't. E,

**THE ALLEN MFG. CO.,  
HARTFORD 1, CONN., U. S. A.**

# QUICK SUBSTITUTION BOX

By CHESTER T. MARTOWICZ

**T**HIS hand push-button operated device was originally designed to indicate rapidly the exact value of capacity or resistance or RC combination required in a particular circuit for proper operation. It is an invaluable aid in radio servicing where faulty components of unknown values must be replaced, or existing components are to be checked by substitution.

The unit is inexpensive and relatively simple to construct. It consists of two sets of push-button switches such as are employed on ordinary radio receivers for fixed station selection, a variable resistor and a channel selector switch all mounted in a compact metal box only 5 x 4 x 3 inches. The sole function of the channel selector toggle-switch is to select the proper row of push-buttons.

It is recommended that dual-section or triple-section electrolytic condensers be used whenever possible to eliminate the unnecessary crowding of parts with the attendant difficulties in wiring such a compact device. Be careful to observe proper polarity when wiring the electrolytic condensers into the circuit.

Although this unit employs two sets of push-button switches, a multiple contact single push-button assembly would serve as well. In such an arrangement, however, any given button would have two sets of values either of which could be chosen at random by the position of the channel selector switch. Numerous other variations of the basic idea are of course possible and very often desirable. For example, a second unit constructed by the author had, in addition to all the values of capacity and resistance contained in the original unit, a complete set of mica capacitors for plate circuit by-pass tests.

In the actual operation of the device it is merely necessary to substitute or bridge the component under test with the unit to determine its operating efficiency. In many cases of insufficient filter capacity, for example, this device will indicate exactly how much additional capacity must be added to an existing filter to restore a receiver to its normal operating condition. It should be noted at this point that by depressing any two or more buttons simultaneously the results are additive since the individual components are wired in parallel. This gives combination values of capacity which will satisfy all unusual requirements.

Another valuable application of this device is in determining experimentally proper values of resistance and capacity in any parallel circuit arrangement (as cathode biasing). By depressing the resistor button simultaneously with one or more capacity buttons in the same channel this condition is readily attainable.

Radio servicemen frequently run up against the difficulty of replacing burned-out carbon resistors. In many

cases the exact value is unknown since all identifying marks have been obliterated. By simply substituting the universal test device for the burned-out resistor and rotating the variable resistor the optimum resistance value can be easily determined. After measurement with an ohmmeter the exact value can then be permanently wired

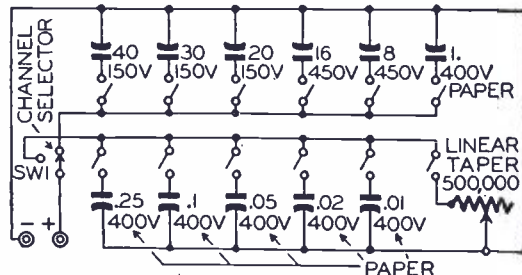

A wide range of resistance and capacity values are rapidly substituted by push-buttons.

into the receiver. Resistance substitution by this method must be handled cautiously. The "optimum" value to the ear may not always be best for tubes or other parts. In some cases, volume will rise as the circuit approaches oscillation, and there is danger of substituting a value which would make for instability of operation.

There are countless other uses for this simple instrument, which will save incalculable time for the average radio serviceman, technician, or experimenter. While the idea of a "Substitutionalyzer" is by no means new, this type has many advantages in convenience and speed of operation which make it well worth construction.

## FM COSTS NOT EXCESSIVE

**S**URVEY of costs of FM broadcasting equipment indicates operation is "well within the reach" of small enterprise, Senator Glen H. Taylor of the Senate Small Business Committee stated last month.

"Radio broadcasting," Senator Taylor said, "need not be exclusively a big business game. The survey reveals that the cost of equipping a station is far less than most people realize, and that radio broadcasting is well within the reach of small business enterprise, farm groups, cooperatives, labor unions and educational institutions."

"The manufacturers' estimated costs for principal technical equipment for a small 250-watt station average around \$9,508. Although other expenses such as real estate, studio furniture and construction must be met before a station is ready to go on the air, this low cost for FM transmitting equipment means that it is possible for ownership in the FM band to be widely dispersed."

Heat in television studios may be eliminated by a new heat-absorbing, color-transmitting glass recently developed.



# Available Radio-Electronic Literature

Manufacturers' bulletins, catalogs and periodicals.

**A NEW SERVICE FOR RADIO-CRAFT READERS:** In order to save your time, postage and incidental work in writing a number of letters to different manufacturers to secure the various bulletins offered, proceed as follows:

On your letterhead (do not use postcards) ask us to send you the literature which you designate. *It is only necessary to give us the numbers.* We will then send your request directly to the manufacturers, who in turn will send their bulletins or other literature directly to you.

## 199—TONG TEST AMMETERS. Issued by Columbia Mfg. Co.

This leaflet describes the various types of tong test current-transformer type ammeters which work on a moving iron principle. Description of the units and instructions on operation are included with samples of typical meter scales.—*Gratis*

## 200—SELECTRONIC CRYSTALS.

A catalog put out by the Crystal Research Laboratories, Inc. This leaflet describes the different types of plug-in crystals and illustrates their methods of test and manufacture of crystals.—*Gratis*

## 201—TRANSMITTING TUBES.

This is a chart put out by Amprex listing the majority of transmitting tubes and competitive designations. It is merely a comparison chart and contains no characteristics or other detailed operation on the individual tubes but would find its place in a broadcasting studio or ham shack.—*Gratis to interested parties.*

## 202—INTRA-TELE SYSTEMS.

Offered by the General Electric Company. This booklet describes the units, layout and optional equipment for an intra-store television layout.—*Gratis to interested stores or businesses.*

## 203—TELEVISION

A leaflet published by the United States Television Manufacturing Corporation. This shows what the post-war television set will look like and lists in addition, FM sets, portables, and table model combinations scheduled to be manufactured by this company.—*Gratis*

## 204—VIBRATOR GUIDE

This guide is published by the P. R. Mallory Co. It lists the vast majority of replacement vibrators for all sets. Listing is by manufacturers and there is a cross-reference by vibrator type and manufacturer's replacement part number.—*Gratis to interested parties.*

## 205—FREQUENCY METERS

A catalog, issued by the James G. Bidle Company, listing various types of Frahm vibrating-reed frequency meters. Constructional characteristics, data sheets and general information on this type of meter are included in the booklet.—*Gratis to interested parties.*

## 206—REPLACEMENT GUIDE

The usual battery replacement guide offered by the Burgess Battery Company. Compiled and edited by Homer G. Snoopshaw, B.R.S. (Battery Replacement Specialist). Lists the majority of portable receivers by manufacturer and the replacement batteries for these receivers. In addition, there is a listing of private brand receivers and their battery replacements.—*Gratis*

## 207—RADIO COMPONENTS

The A. W. Franklin Company has put out a catalog, beautifully bound in imitation leather and gold-embossed, listing its line of switches, plugs, sockets, assemblies, locking rings, terminal strips, metal stampings, plastic fabricated parts, etc.—*Gratis to interested parties.*

## 208—HANDBOOK

An offering of the Eastern Brass & Copper Company, this handbook is a veritable storehouse of information for the engineer. It is composed mainly of tables and charts on gauges, expansion factors, and measures of various metals. An interesting section is devoted to coloring, pickling and dipping.—*Gratis to interested parties.*

## 209—BOOKLET

Published by the Merit Coil and Transformer Corporation. This booklet delivers the story of this company and its achievements, and, in addition, has the main portion of its contents devoted to full-color photographs of the Signal Corps in action.—*Gratis to interested parties.*

# SUPREME PUBLICATIONS

These are the practical radio manuals you need. Improve your radio knowledge. Speed up service work. Check manuals you want, write name below, and send this entire ad. as your order.

## MOST-OFTEN-NEEDED DIAGRAM MANUALS



Use these diagram manuals to find all radio faults quickly. These large, inexpensive circuit manuals have the data for all popular sets.

1942 Manual, 192 pages.....\$2.00  
1941 Size: 8½ x 11 inches..... 2.00  
1940 Manual, 208 pages..... 2.00  
1939 Manual, 192 pages..... 2.00  
1926-1938 Manual, 240 pages.... 2.50

## OTHER TECHNICAL RADIO BOOKS



Radio Servicing Course-Book  
22 lessons, 8½ x 11", 221 pages ..... \$2.50

Record Players & Recorders  
All makes, 8½ x 11", 128 pages ..... \$1.50

Practical Radio Mathematics 25c

Refrigeration Manual .....\$1.00

Cyclopedia of Television.....40c



Simplified Radio Servicing by Comparison Method

New, revolutionary different method makes radio repairing twice as easy. Introductory training included. Simple picture suggestions tell you where to look for faults and how to make the repair. No testers needed for most jobs. With job-sheets, blue prints ..... \$1.50

SUPREME PUBLICATIONS, 9 S. Kedzie, Chicago 12, Ill.  
Check manuals wanted, send remittance with complete advertisement or write order in a letter. Books sent postpaid. Money back guaranteed.

Name: .....

Address: .....

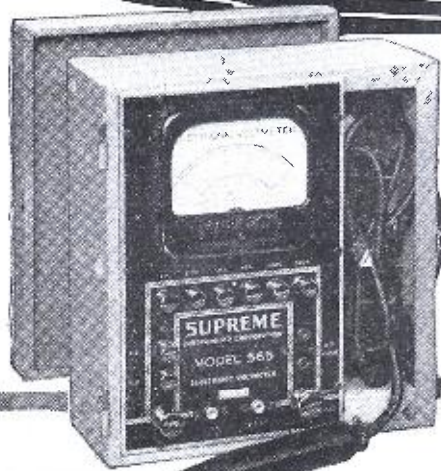
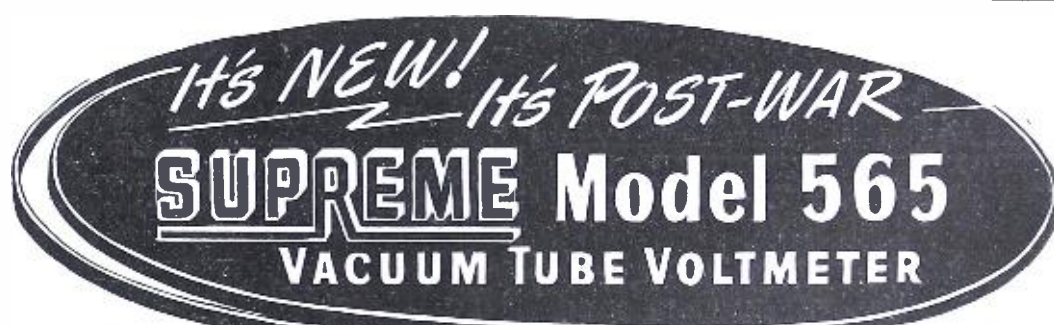

NEW PROBE Streamlined Hand Fitting Incorporating new High Frequency Diode

RANGES:  
DC 0-1, 2.5, 10, 50, 250, 500  
AC 0-1, 2.5, 10, 50, 250  
EXTENDED TO 5000 VOLTS BY EXTERNAL MULTIPLIERS

INPUT RESISTANCE:  
DC—80 megohms on 1 volt range; 40 megohms on 500 volt range  
AC—40 megohms on 1 volt range; 20 megohms on 250 volt range

INPUT CAPACITY OF PROBE: 5 micro-micro farads

FREQUENCY RANGE:  
Negligible frequency error from 50 cycles to 100 megacycles.

SUPREME INSTRUMENTS CORPORATION GREENWOOD MISSISSIPPI





## LANGUAGE IS POWER

... Forge ahead, win special assignments, promotion, better job in global peace time opportunities through ability to speak a foreign language.

**MASTER A NEW LANGUAGE quickly, easily, correctly by**

## LINGUAPHONE

The world-famous Linguaphone Conversational Method brings voices of native teachers INTO YOUR OWN HOME. You learn the new language by LISTENING. It's amazingly simple; thousands have succeeded.

**HOME-STUDY COURSES IN 29 LANGUAGES**

Send for **FREE** book—

## LINGUAPHONE INSTITUTE

66 RCA Bldg., New York 20 • Circle 7-0830

LINGUAPHONE INSTITUTE,  
66 RCA Bldg., New York 20, N.Y.

Send me the **FREE** Linguaphone Book.

Name .....

Address..... City.....

Language Interested.....

## Whatever YOU WANT In A HEADSET

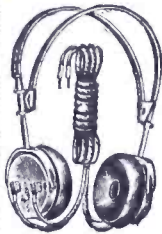

Scientifically Built  
Heavy bar magnets greatly increase their efficiency.

You'll find in a Cannon-Ball Guaranteed Headset. Sensitivity, Clarity of tone. Dependable performance. Quality at fair price. Folder R-3 illustrates complete line. Write Headset Headquarters.

**C. F. CANNON COMPANY**  
SPRINGWATER, N. Y.

In the Rocky Mountain Region

it's

**RADIO & TELEVISION SUPPLY CO.**

806 EUCLID AVE., PUEBLO, COLO.

"If we don't have it, we'll get it—  
or it can't be had! Phone 5729"

## CRABTREE'S WHOLESALE RADIO

2608 Ross Ave.

**DALLAS 1 TEXAS**

### RADIO SERVICEMEN:

**RADIO PARTS—TUBES**

BARGAIN PRICES—NO PRIORITIES

PHONO MOTORS, 9-inch T.T.	\$2.99
CRYSTAL PICKUPS, 1 oz.	2.79
FILTER COND., 20-20 Mfd. 150 V.	.39
BY PASS COND., .01, .02, .05, 1-600 V.	.07
LOOP ANTENNA (High Gain)	.59
ANT. & OSCIL. or ANT. and RF COIL SETS	.69
RESISTOR KIT—50 Ass'd. 1/3 to 1 Watt.	.99

Write Today for Bargain Bulletin  
RADIO DISTRIBUTING CO., Pasadena 18, Calif.

Of the earth's 92 elements, more than one-third, or 35, are used in the manufacture of electronic tubes. This is a larger number of elements than is required in the makeup of any other class of manufactured product.

## MINUTE PRESSURE CHAMBER

**N**OT a bit larger than a custard cup, a test chamber at the Army Air Forces Center, Orlando, Florida, enables radio technicians to observe the effects of stratosphere flying—up to 60,000 feet altitude—on small radio parts. This "baby" pressure chamber, said to be the smallest in the world, can simulate, in less than four seconds, the exact pressure of various altitudes upon radio transmitters and receivers, from sea-level up to 60,000 feet.

Resembling more a miniature container for goldfish than a miniature chamber for testing radio parts, in actuality it is an airtight glass bowl, on the inside of which are tiny switches, condensers, transformers and other radio parts. They are tested as to their behavior at the near-vacuum pressures of high altitudes. The enclosure or bowl itself may be placed inside a conventional temperature chamber for studying radio equipment when submitted to the combined altitude and temperature tests.

This unusual midget "laboratory" for testing apparatus was designed and built by the Army's Aircraft Radio Laboratories at Wright Field, Dayton, Ohio. The chamber itself consists of a duralumin base on which are mounted test specimens, a Pyrex cup or glass bowl, vacuum sealed to permit pressur-

ization, and a group of valves and control switches for regulating changes in air pressure to simulate varying heights.

Controlled changes in pressure are effected by affixing a large vacuum tank to the testing equipment, while fragile needle valves govern the rates of climb and descent in the enclosed, make-believe airplanes.

When post-war flying aims to navigate through the atmosphere at 40,000

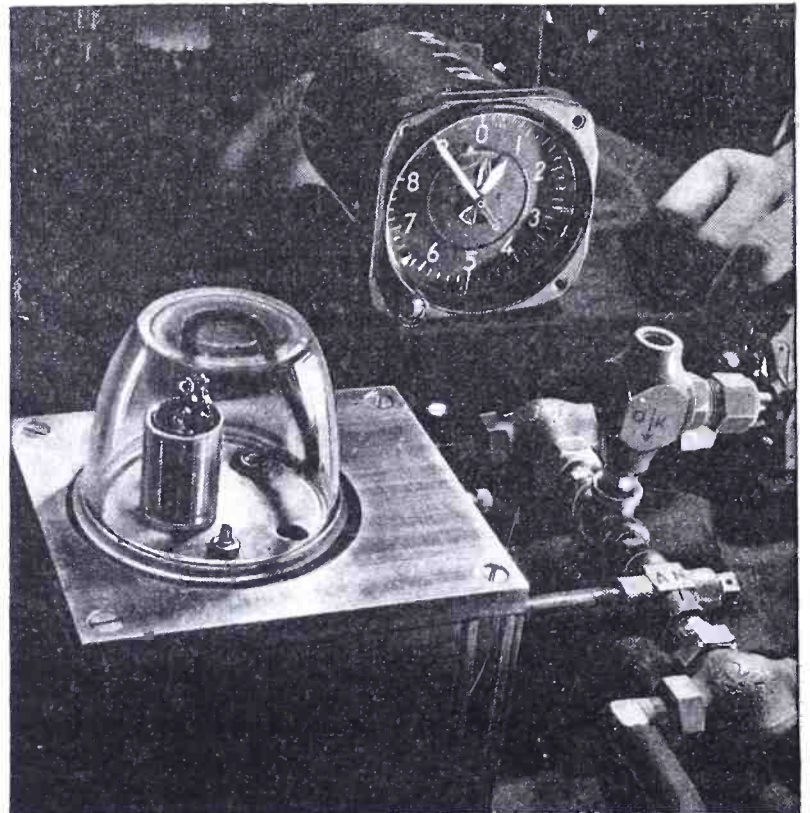

to 60,000 feet, and with jet-propelled planes attaining the speed of sound this tiny test chamber or bowl may prove very important in testing radio equipment; equipment that will not only afford communication facilities, but "pilot" and land aircraft—all by means of electronics or radio.

## MICROWAVE TUBE HAS LONG LIFE

Here is another example of wartime tube design. This comparatively small, air-cooled radar transmitter was originally designed with a tantalum plate and gave only a 50 hour life under heavy surges at very high frequencies in radar service. Its life later was extended to approximately 300 hours but with this high mortality rate thousands of tubes had to be produced quickly to meet urgent wartime demands.

While specifications of the armed forces called for a minimum life of 500 hours in radar service, life tests in the field showed that Sylvania VT-127-A tubes were going strong at 5000 hours. Since this was ten times the required life, these tubes acquired a new Signal Corps nickname: "The Marathons." Continuing field tests showed no signs of failure at the end of 10,000 hours when "The Marathons" were returned to the engineers who had upped their lives more than thirty times.

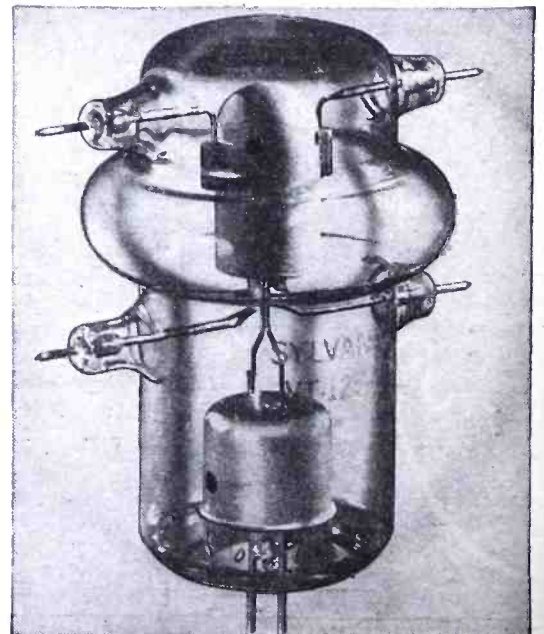



## DUMMIES SAVE TUBES

By EARL T. HARTLINE

ANYONE who has serviced portable receivers using the 1.4 volt tubes knows how easy it is to burn out one or more tubes while measuring voltages. If, while testing plate voltage on pin 3, pin 2 is accidentally touched at the same time, one tube is immediately burned out if they are in series, or maybe all of them if in parallel. Also, if you find a tube in a set that has a blown filament, it is reasonable to suspect that some trouble in the circuit caused the failure. The expensive way is to put in a new tube and try to find the trouble before it burns out. After burning out three 1A7's while looking for a short, I worked out the following method of using dummy tubes until all voltages are measured and any voltage troubles corrected:

Break the top of several 8-prong tubes. For tubes that draw .05 amps filament current, such as the 1A7, 1N5, 1H5, 1A5, connect a 28-ohm resistor between pins 2 and 7. For tubes that draw .1 amp. such as the 1C5 and 1Q5, connect a 14-ohm resistor between pins 2 and 7. For the 3Q5, use two 28-ohm resistors in series between pins 2 and 7 and connect the center tap to pin 8.

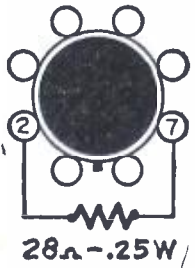

(a)—Dummy which replaces any .05-ampere tube where a filament burnout danger exists.

15- and 30-ohm resistors may be used in place of odd sized 14- and 28-ohm units or they can be wound from fine copper wire. Power rating need be only 1/4 watt.

On the dummies that are to be used in the output stage, 1A5, 1C5, 1Q5, 3Q5, etc. connect a 10,000-ohm 1-watt resistor between pins 3 and 7. This will place a load of 9 or 10 mils on the plate supply so "B-plus" voltage can be measured under normal load. There is a definite reason for using the output stage for this plate load. If the filaments are in series, this plate current may flow through the filament circuits of some of the tubes, depending on which tube's filament is grounded. Since the output tube normally draws from half to three fourths of the total plate and screen current, any error caused by this current flowing through the filament circuit will be negligible.

An adequate set of these dummy tubes would be five for .05 amp tubes, one for .1 amp tubes and one for the 3Q5.

This same method can, of course, be worked out for loctal and miniature tubes.

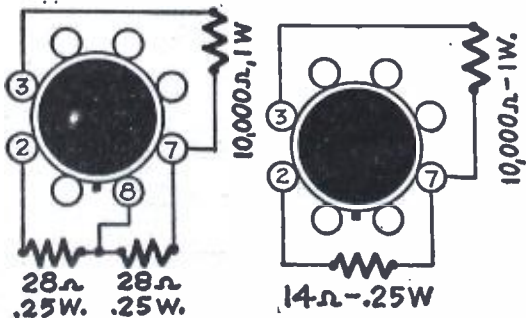

(b)—0.1-ampere dummy, (c) dummy for 3Q5.

The idea is illustrated in the figure, (a) being for tubes drawing .05 ampere, (b) for 0.1 ampere tubes, and (c) for the 3Q5. The 10,000-ohm dummy plate load is also shown.

## THERE'S PROFIT in ELECTRICITY... LEARN from PRACTICAL ELECTRICS, \$1.00



Whether you want to enter the electrical field as a profession — or whether you want to know more about fixing electrical gadgets around the house, you will find Practical Electrics a profitable investment. You can find the right answers quickly. It gives you the fundamentals of electricity, electrical circuits, motors, transformers, electrical symbols, trouble shooting, etc. — all in plain, simple, understandable language. Send \$1.00 today for a copy of Practical Electrics, the ready reference book of electricity.

**AUTOPOWER, Inc.**

2118 PINE STREET • ST. LOUIS 3, MISSOURI



## Civilian RADIO JOBS Wanted

### FREE WANT-AD SERVICE

**TELEVISION MAINTENANCE.** pre-war electronic exp.; three years Navy—radio, radar, television; specialty camera unit. H.S.; 2 yrs. college; 22, single, ambitious. Stanley J. Rothstein, 240-A Vernon Ave., Brooklyn, N. Y.

**RADIO,** television or electronic instrument maintenance, repair; 3½ years' experience maintenance Army type search and gunlaying radar. Technical Sgt. in Pacific in charge of radar repair crew. Graduate of three Army radar schools. Holds civil service radio mechanic technician's certificate. High school education. Desires career opportunity. Lester Huff, 114 Elm St., Owensboro, Ky.

**EXTREMELY** mechanically inclined. Licensed amateur; 3 yrs. Army operating and maintenance. Code speed 30. Prefer radio or mechanical work with future. Joseph Tartas, 320 Sterling St., Brooklyn, N. Y.

**REPAIRMAN**—radio, 24, single, 1½ yrs. civilian experience, 3 yrs. with AAF and Signal Corps. Neat, versatile, dependable. Graduate RCA Institutes. Stanley Wand, 937 Vine Street, Camden, N. J.

**EX-USN-RT.** 19 yrs. in radio service. 5 yrs. mgr. wholesaler service and parts dept. College. Married. Can meet public. Desires any permanent pos. involving electronics. Service, lab. or other. Will consider purchase service shop. Fla. town about 5000 pop. All communications answered. Paul F. Thompson, Forest City, Iowa.

**TECHNICIAN**—radio, electrical, 10 years' civilian, Army exp., maintenance, construction, installations including amplifiers, intercommunication, FM, radio. Possess complete test equipment. N. A. Zuloff, 303 S. 1st St., Brooklyn, N. Y.

**RADIO TECHNICIAN:** 3 years' exp. installation, testing, modification and repair aircraft radio. Exp. also repair and conversion commercial receivers. Familiar all test equipment. Can type, drive; seeks servicing or laboratory position with future. Single, age 33. Murray Cohen, 132 Penn St., Brooklyn, N. Y.

**AMBITIOUS:** 23; 1 year Army radio-radar repair training; seeks future in radio field; willing to learn; 1 year college. Stanley Klein, 9205 Flatlands Ave., Brooklyn, N. Y.

**ELECTRONICS TESTING** or laboratory position desired. Ex-chief radioman; 5 years' experience in radio and radar. Hold radiotelephone license. Capable, efficient, manage personnel. T. R. Reiner, 1516 East 7th St., Brooklyn, N. Y.

**RADIO:** Navy radio technician, 3 yrs. exp. transmitters, receivers, Loran; knowledge micro-wave technique; 3½ yrs. coll. J. Lippman, 64 W. 83rd St., New York 24; SU 7-7888.

**RADIO** telephone, 1/c lic., 4 yrs. exp. repairing all types receiving, transmitting, direction-finding,

blind-landing equip.; pre-Army trained. Jack Munt, 2920 Holland Ave., New York 67, N. Y.

**RADIO TECHNICIAN GRAD.:** reliable institute, coll. background; married; alert, ambitious. Jan Charo, 3883 Bedford Ave., Brooklyn, N. Y.

**RADAR OFFICER;** 4 years Army. Specialized sighting and operations; 1½ years' commercial communications; amateur and commercial licenses; BA Physics; 27; married; desire West Coast. D. Scott, 326 W. 89th St., New York, N. Y.

**RADIO**—sales or production. Graduate Princeton University (BA) with math through calculus. Radio operator and technician for International Grenfell Association. Three years' advertising. Reporter Baltimore "Sun." Four years' communications officer air stations US Navy. Honorably discharged rank of senior lieutenant. Fifteen years radio amateur. Read and speak Portuguese and French. Address replies to: Robert M. Crooker, 3816 N. Maryland Ave., Milwaukee, Wis.

**RADIO TECHNICIAN:** 10 yrs. diversified exp.; 2d cl. radio, teleg. and teleph. and el. A amateur licenses; desires pos. Hyman Wolinsky, 133 Penn St., B'klyn 11.

**ELECTRONICS, RADAR** — Civilian background; B.S. physics; 5 yrs. teaching science city schools, army; formerly army communications radar officers. Anthony E. Catinello, 1272 77th St., B'klyn 28.

**NAVY EXPERIENCE AND SCHOOLING.** Pre-service experience directing crew assembling and wiring transmitters. Desire job with future. New York or nearby. References. Box No. V346, "Radio-Craft", 25 West Broadway, New York, N. Y.

**RADAR TECHNICIAN,** 3 years army experience. Desires position in television or broadcasting network. Willing to attend further schooling. Gerard Marciano, 1629 8th Ave., Brooklyn, N. Y.

**POSITION WANTED:** Radio repairman or radio technician. 4 yrs. experience on all types of Receiving and trans. Equipped as a Radio-Technician 3/c in the U. S. Navy. Mr. Robert Spero, 25-59 41st St., Long Island City, N. Y. RA 8-8582.

**RADIO TECH.,** 22; radar exp.; familiar with all types electronic equipment; ex-navy tech. 1/c; some design exp. Leon Sher, 59 Lewis St., N. Y. 2.

**RADIO TECHNICIAN:** 3½ yrs.; AAF airborne equipment; electrical repair; chauffeur's license; tech. grad. Norman Rothbard, 1471 St. Marks Ave., B'klyn 38, Glenmore 2-1715.

**ARMY RADAR MAN,** previously photographer; exp. darkroom technician; seeking employment in either. M. Garber, 2077 Dean St., B'klyn 11. GL 5-5861.

**RADIO-ELECTRONICS**—Desires job in field; attending Pratt Inst. eyes. R. Tillman, 35 E. 58th St., B'klyn 3. DL 2-5326.

### TELEVISION MEN DISCUSS COLOR

Dr. Allen B. Du Mont, president of Du Mont Laboratories, in the course of discussing various aspects of the proposed rules, stated that "to make a substantial investment in television in the lower frequencies with the advent of commercial high definition color television practically upon us not only would be unwise but utterly fool-hardy."

John Shepard of the Yankee Network said, "it is our considered opinion that both the interests of the industry, both manufacturing and operating, would be best served by abandoning the suggestions for the establishment of commercial television below 300 megacycles at this time, and by the

establishment of such service in higher frequencies at the earliest date practicable."

Dr. Goldmark said that by using an inexpensive directional antenna, ghost-free reception would be possible in the high-frequency transmissions. "It was found during the tests," he added, "that a signal reflected from a nearby tall building corresponded to a transmitter radiating one-hundredth of a watt radiated in all directions uniformly." This means that an area like New York could be covered by "a transmitting power of less than one-tenth that which is required in the present low-frequency television bands."



## TELEVISION TECH CORRESPONDENCE COURSE

**WANTED:** Radiomen to take a specialized television course. Instructions begin and end with television. Course has been written for the Radio Serviceman who wishes to learn television repair, and the radio commercial operator who wishes to prepare for this new field. A knowledge of basic radio is assumed.

**PREPARATION:** Authors of a major part of this course are O. J. Jimerson and Edward M. Noll.

Mr. Jimerson is a member of the television staff of a major radio corporation.

Mr. Noll has written a number of articles on television and was associated with the same corporation.

BOX 94 HATBORO, PA.  
DEPT. A

## SOUND VALUES at TERMINAL RADIO

### High Quality CARBON-TYPE HAND MICROPHONE

Made by Shure for the U.S. Army Signal Corps—type T-17. Excellent reproduction of voice frequencies. A real buy at Terminal!

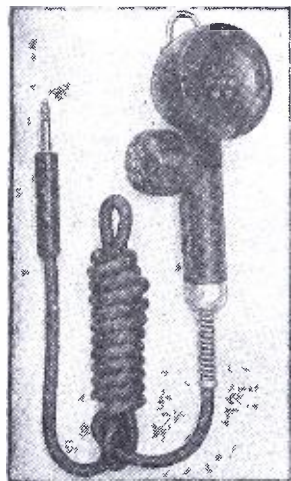

- ★ Ideal for Radio Transmitters, Mobile P.A. Systems, Call Systems, etc.
- ★ 200 Ohm, Single Button, High Quality.
- ★ Press-to-talk Button Operates R.I.y and Microphone.
- ★ Built-in Filter for Suppression of Carbon Hiss.
- ★ Sturdy Construction—"Can Really Take a Beating."
- ★ Guaranteed Brand New, in Sealed Cartons.
- ★ Complete with 5 Feet, Three-Wire, Rubber Covered Cable and 3 Circuit Phone Plug.
- ★ Moisture-Proof Cover.

**\$2.89** net

Add 15c for shipping charges when ordering by mail.

**TERMINAL**  
Radio Corporation  
85 CORTLANDT ST. N. Y. 7, N. Y.  
Worth 2-4415

## RADIO HEARING AID

(Continued from page 392)

may be applied to the converter only since the 1S5 amplifies both at i.f. and a.f. Besides the 1S5 is not a variable-mu tube.

The positions of the switch are: Off; 1 — Hearing-aid; 2 — Radio-Hearing-Aid; 3—Radio. Since we were unable to procure a very tiny switch we depended on plug-in contacts.

To easily visualize the operation of the tube 1S5 and its relative input and output circuits, we may refer to the conventional reflex amplifier. In a reflex amplifier the tube amplifies at r.f. or i.f. and at a.f. The a.f. results from the demodulation of the r.f. or i.f. In the

i.f. (radio) and a.f. (microphone). The i.f. signals are also demodulated by the diode section of the 1S5. In this position the apparatus works as radio and hearing aid.

In position 3, the microphone is disconnected. The 1S5 amplifies only i.f. (and demodulates). This is the "radio only" position.

The second 1R5 is an audio-frequency mixer. The a.f. rectified by the diode is applied to grid 1, a.f. amplified by the 1S5 to grid 3. In the plate circuit of the second 1R5 we find both signals in amplified form when grids 1 and 3 are both operating. We find only one signal when

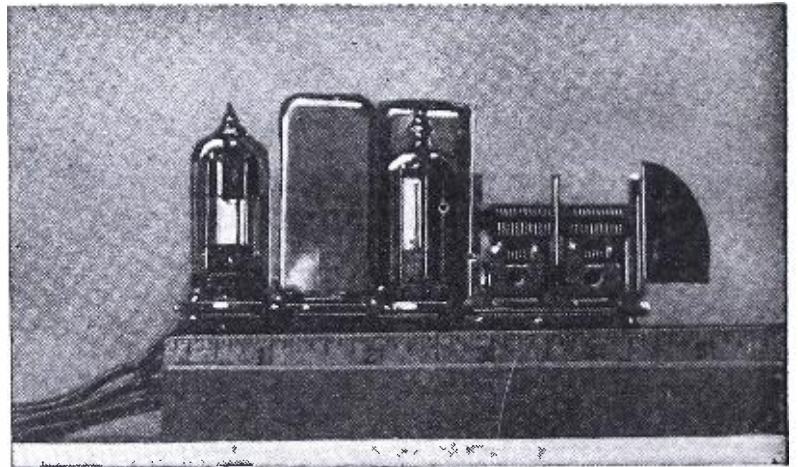

Chassis of the little receiver measures less than 4½ inches from front to rear, and the overall length, including knob, is just a little more.

present case the a.f. is generated by the microphone.

The important switch decks are the ones located between the first 1R5 and the 1S5. When they are in position 1, the plate section of the oscillator coil is short-circuited and therefore the first 1R5 does not convert any frequency or produce any i.f. The 1S5 therefore amplifies at a.f. only. The amplified a.f. appears across the 1-meg resistor located after the primary of the i.f. coil and is applied through an .001 µf condenser to the third grid of the second 1R5. The second 1R5 is used as an audio-frequency mixer.

### THE SWITCH POSITIONS

The fact that the secondary of the first coil is in the input circuit of the 1S5 and that the primary of the second i.f. coil is in the output of the same tube does not impair the performance at a.f. The reactance and mutual inductance of the i.f. coils is infinitesimal at low frequencies. In position 1 the apparatus works as a hearing aid where the 1S5, the second 1R5 and 1S4 all amplify at a.f.

In position 2, the oscillator coil works. The i.f. is applied to the input of the 1S5. In the output, the second i.f. coil applies the i.f. to the diode section of the same tube. The output is fed to the first grid of the second 1R5. The two 50-µf condensers in the input and output of the 1S5 close the i.f. path to ground. The microphone is still connected and its output is amplified as when switch is in position 1. In this case the 1S5 amplifies at

either grid 1 or grid 3 is working alone.

No definite assembly sketch can be given since the location of the component parts depends too much on their physical shape.

The sensitivity of the radio receiver is better than 400 microvolts r.f. input (Broadcast band) for 50 milliwatts a.f. output.

### MINE LOCATOR SAVES LOGS

Mine detectors have found a new use, according to a report in *Science Service*. This time the mine detector is being used to ferret out pieces of metal in saw-logs, thereby preventing damage to the sawmill machinery.

A large lot of the logs, felled to enlarge an artillery range near Fort Bragg, N. C., was purchased by a local lumber company. Many of the logs had imbedded in them shell fragments from past firings, and whenever a saw hit one of these chunks of steel it tore off its teeth. After ruining \$300 worth of saws, the sawyer was ready to give it up.

Army engineers suggested the use of the type of mine detector that gives a warning buzz when it comes close to hidden metal of any kind. One of these detectors was passed over a log. At a certain point it buzzed. Chopping disclosed a three-inch steel fragment buried two inches deep in the wood. When this was removed the log was sawed up without any further unfortunate incidents.

The detector has been used on all logs since, and has paid for itself many times.

Crystals of potassium hydrophosphate are being used instead of natural quartz crystals for frequency control in radio transmitters manufactured by a Swiss firm.







# COMMUNICATIONS

## EVERY MAN HIS OWN INDEX MAKER

Dear Editor:

To B. Buehrle, Jr.'s suggestion in the December, 1945 issue: "Why not print a yearly index of *Radio-Craft* at the end of the December issue" so that the readers would know just where to find a given article or story, I'd like to append the following "Why not":

Why not (when you have just finished reading the latest issue of *Radio-Craft*), mark on the cover the title and the page number of articles that interest you, which you think you might have need to refer to, later?

That's what I do. It works fine; saves me a lot of time, saves the editors a lot of time (and money making up an index) and since, as the Editors just

stated, "not many readers desire it," my method is the best one to employ in the circumstances. It also has the advantage of eliminating a lot of unnecessary reading of titles of articles that do not interest you, which would happen if a complete index for the year were printed.

To Mr. Buehrle's other idea: "Why not use a 110-volt neon light as pilot light," I think the idea is good—*why in the heck don't they?* Every radioman has to spend a lot of time on pilot light failures that might be applied in other work if this defect were eliminated from radio receivers.

JOSEPH AMBROSE,  
Richmond, Va.

## GIVES R-C JUST ONE MORE CHANCE

Dear Editor:

I am sorry for the delay in answering your notice that my subscription is running out, but I fully intended to write you telling you that I didn't intend to renew it.

I am in the service business and used to enjoy the articles on trouble shooting in sets, also the diagrams that always came in handy. Lately there hasn't been enough to interest the serviceman, so I was going to drop it.

In radio broadcast work, I think you know the average operator has enough to do at the station and isn't interested in electric meter control by vacuum tubes, in welding control, etc., so that is the reason I dropped them.

I hope that in the future more space will be devoted to the service business. Please extend my subscription for another year and we will see the results.

JOHN J. ZANDER,  
Camden, N. J.

## KINK CONTRIBUTOR MISSED THE POINT

Dear Editor:

I came across a kink which was printed on page 264 of the January, 1946, issue of *Radio-Craft* submitted by Arthur Shogren, operator of Radio WAY, Chicago, and purporting to show limitations of and suggested improvements to, a type of tone control similar to that described in the June, 1940, issue of the magazine.

Your contributor fails to understand one important factor behind this control circuit. That is, it was specifically designed to meet a predetermined operating specification, and was not developed in a hit-miss manner. The tone control circuit, when employed with a proper inter-coupling network, will provide a range of  $\pm 10$  db at 10,000 cycles and  $\pm 10$  db at 100 cycles. The dual function of the control to provide equivalent boost and cut, is a highly desirable feature, and cannot be attained in any other circuit which matches this one for simplicity.

The value of the condensers have not been compromised. They are the ideal values for the function intended. The writer indicates "When C1 is made large enough to provide proper attenuation of the high frequencies in the cut position, the amount of accentuation in the boost position becomes excessive." It will be noted that no defi-

inition has been provided for proper attenuation or excessive. He goes on to discuss the same defect when applied to the bass control, but in no way indicates what he considers the absolute value of proper boost or cut.

His later objection is that the mid-setting of the bass control provides high frequency attenuation, is similarly erroneous. This condition does not exist in any of our amplifiers. In fact, it is no trick at all to set the boost and cut control to maintain a response of  $\pm 1$  db from 20 to 20,000 cycles. Your contributor evidently failed to take into consideration the input capacitance of the succeeding stage.

The circuit suggested by your contributor was tried in our laboratory in 1936. It exhibited definite disadvantages, and was abandoned. It is to be noted that the contributor specifically states: "The values shown are merely suggested ones and need not be copied exactly. Perhaps a little experimentation might be necessary before the ideal set of conditions is obtained." In view of the fact that he omitted to define the ideal set of conditions, I doubt whether any amount of experimentation will produce his undefined ideal.

A. C. SHANEY,  
Amplifier Co. of America,  
New York, N. Y.

## THIS MONTH'S SPECIALS!

	Your Net
6-volt 4-prong universal vibrator. List \$3.95	\$1.89
10-12 tube power transformer 6.3V. winding 100 Ma.	3.09
4" speaker case only for talk back or P.A. systems	.69
100 asst. 1 & 1/2 watt resistors up to 10% tolerance	2.45
New 6L6 metal tubes in original cartons	.89
Headphones, Signal Corps. 8000 ohm. List \$10.00	2.95
Telegraph Keys with cutout switch	.95
2500 mfd. 3 volt F.P. condensers	.69
Tubular Electrolytic Condensers	
15 mfd. 450 W.V.	.42c
20 mfd. 150 W.V.	.35c
20-20 mfd. 150 W.V.	.55c
50-30 mfd. 450 W.V.	.75c
Tubular Bypass Condensers 600 W.V.	
.01 and .02	.7c
.05	.8c
.1	1.0c
1/4 mfd.	1.5c
1/2 mfd.	2.2c

Plus shipping charges

Write for our illustrated literature featuring all types of radio parts.

Order from your jobber or write direct: Dept. D

**ARROW RADIO CO.**

2205 W. Division St.

Chicago 22, Ill.

## Get Started in Radio



### 10 "HOW-TO-DO-IT" BOOKS

Get a solid foundation in radio by means of these 10c timely text books. Each clearly written, profusely illustrated, contains over 15,000 words. You'll be amazed at the wealth of information packed into these handy books. Excellent for reference—ideal for technical library. Your money back if not satisfied.

5 BOOKS for 50c

10 BOOKS for \$1.00

Sent to You Postpaid

- |  |                                     |
|--|-------------------------------------|
| No. 1—How to Make Four Doozie Short Wave Sets                      | No. 6—How to Have Fun With Radio    |
| No. 2—How to Make The Most Popular All-Wave 1 and 2 Tube Receivers | No. 7—How to Read Radio Diagrams    |
| No. 3—Alternating Current for Beginners                            | No. 8—Radio for Beginners           |
| No. 4—All About Aerials  | No. 9—Simple Electrical Experiments |
| No. 5—Beginners' Radio Dictionary (Leading Terms)                  | No. 10—Television                   |
- Remit by check or money order—register letter if you send cash or stamps.  
RADIO PUBLICATIONS, 25M West B'way, New York (7)

## Short-Cut Mathematics

COMBINED WITH  
*Practical Mechanics Simplified*

NEW 2-in-1 reading course! Now you can learn the speedy, simplified system of calculation used by draftsmen, engineers, accountants, "master minds" on the stage. Learn easy way to multiply 4 figures by 4 figures without using old-fashioned multiplication; add long columns of figures this lightning short-cut method. Learn horsepower, slide rule, micrometer, logarithms, wood measure, puzzles, etc., etc. Large illustrated volume complete with answers, only \$1 postpaid. Satisfaction or refund. Amaze friends with your magic-like mental powers.

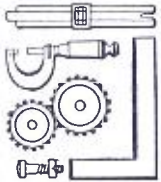

FREE Complete details... mail coupon TODAY!

NELSON CO., 1139 S. Wabash Ave., Dept. 3C39, Chicago 5  
Please send free details about "Short-Cut Mathematics and Practical Mechanics Simplified." No obligation.

Name \_\_\_\_\_  
Address \_\_\_\_\_

## TEST EQUIPMENT

—SHIPPED FROM STOCK!

SUPERIOR 400—electronic multimeter	\$52.50
SIMPSON 260—volt-ohm-milliammeter	33.25
RADIO CITY 805—tube and set tester	89.50
TRIPPLETT 666-H—volt-ohm-milliammeter	16.00

25% deposit with order, balance C.O.D.  
Also, many other types available.  
**SCENIC RADIO & ELECTRONICS CO.**

53 Park Place

New York City 7

**L**IGHT MEASUREMENT by means of microwaves has increased the accuracy with which the speed of light can be measured, Dr. William W. Hansen of Stanford University announced last month.

The new and more accurate system, Dr. Hansen stated, will be of great interest to astronomers who use the velocity of light to measure star distances. Accuracy is to  $3 \times 10^{-16}$  second.



# BOOK REVIEWS

**TELEVISION: THE EYES OF TOMORROW**, by Captain William C. Eddy. Published by Prentice-Hall, Inc. Stiff cloth covers, 6½ x 9½ inches, 330 pages, Price \$3.75.

This treatise "covers" television in all its phases from early history to color response of the present-day television equipment. It touches upon studio design, visual effects, television in education, the tele-commercial, lighting, control room equipment, staging, and acting in television.

A chapter on color television brings this seldom-seen, oft-speculated-upon phase of the art up to date, describing the color Orthicon, color slides and film, and latest developments in color-television research.

Another chapter on the use of film in television discusses the possibilities of using training films, cartoons, newsreels, and feature pictures as television subjects but leaves the reader "dangling in the air" as to the pros and cons and eventual outcome of the present impasse between the broadcasters and the film distributors.

Several chapters are above the level of other books written on the subject, but others give the reader just enough to whet his appetite for more; then go on to other subjects.

While it doesn't presume to be a textbook, it does give some useful hints and information for the embryo visual effects man or television actor. It is profusely illustrated, and cartooned by Bill Eddy himself.—E.A.W.

**URANIUM AND ATOMIC POWER**, by Jack de Ment and H. C. Dake. Published by the Chemical Publishing Co. Stiff cloth covers, 5½x8½ inches, 343 pages. Price \$4.00.

This treatise does not touch upon the social or moral effects of the atomic bomb's advent, confining its pages to a treatment for the scientifically-minded individual. More particularly, the student of uranometry would find it valuable.

The first chapter brings the story of research into atomic energy up to date, explains some of its present and future potentialities and explodes some of the myths and rumors which have sprung up since the world first heard of atomic bombs. The second chapter lists and describes the various ores and deposits used as sources of uranium, detailing the what, when, where, how and why of uranium minerals.

Chapter four and five take the reader into the physics of uranium, the structure of its atom; its breakdown and isotopes. The larger part of this space is devoted almost exclusively to the mathematical breakdown of uranium and nuclear fission. This section would interest the chemist or uranometry student.

Chapters six and seven are devoted

to specific and special methods of uranometry, tests on uranium-bearing minerals, quantitative and qualitative analyses, microscopic, polarographic, chromatographic, capillary and spectrochemical methods of determination.

The last 22 pages consist of eight appendices, devoted to values of constants, the international table of atomic weights complete as of 1941, periodic system of the elements, table of natural stable isotopes, isotopic masses; mass of the neutron, neutron sources, the capture of neutrons, beta emitting elements produced in uranium by neutrons, nuclear reactions, radioelement analogs, 6½ pages bringing the atomic bomb up to date, and a special (concluding) note on the uranyl radical. An extensive bibliography of literature on the subject is also appended.—E.A.W.

**RADIO SOUND EFFECTS**, by Joseph Creamer and William B. Hoffman. Published by Ziff-Davis Publishing Company. Stiff cloth covers, 6x8½ inches, 61 pages. Price \$1.50.

This primer on radio sound effects is radio broadcasting as it really is—radio programming with the curtain pulled aside to reveal "how it's done." It was primarily written with the idea of producing a textbook on sound effects; their creation, their effect as an illusionary medium, and their adaptability to radio plays.

The chapters are divided into simple basis categories such as Getting Started In Sound Effects, Use of Sound Effects In Radio, The Mechanics of Sound Effects, Control Room Signals, Manual Effects, Recorded Effects, Trick Effects, Supplementary Sound Effects, Radio's Own Language, and some Do's and Dont's For Sound Effects Technicians.

The chapter on control room signals and the one on radio's own language is an ABC of radio sound technique and is jam-packed with interesting information and illustrative photos on "the fine art of making people believe they're hearing what they ain't."

A short quiz and assignments paragraph at the end of each chapter in textbook style completes the job of combining an instructive text with interesting reading matter.

**FASCINATING DEVELOPMENTS** during 1946 were promised the radio audience by Paul Porter, Federal Communications Commission chairman, in a speech broadcast last month.

"Only a few Americans—a corporal's guard—have ever really seen television," said the FCC chairman. "By the end of 1946 thousands of Americans should be seeing sports contests, public events and plays on a television screen in their cozy living rooms.

"Whereas there are only about 50

# MATHEMATICS FOR RADIO

Two volumes, prepared for home study. Book I (314 pp.) covers the algebra, arithmetic, and geometry; Book II (329 pp.) covers the advanced algebra, trigonometry, and complex numbers necessary to read technical books and articles on radio.

MAEDEL PUBLISHING HOUSE Room 117  
593 East 38 Street, Brooklyn, New York

Send me MATHEMATICS FOR RADIO AND COMMUNICATION as checked below. I enclose payment therefor with the understanding that I may return the book(s) within 5 days in good condition and my money will be refunded.

Name .....

Address .....

- Book I at \$3.75 plus 6c postage  
 Book II at \$4.00 plus 6c postage  
 Books I and II at \$7.75 postage prepaid

Foreign and Canadian prices 25c per volume higher

## DEALERS YOU CAN MAKE A DOUBLE PROFIT THROUGH HANDLING BOOKS

**1. BOOKS BRING YOU BETTER CUSTOMERS**  
They stimulate the interest and knowledge that make steady buyers. The more your customers know about radio the more they will buy from you.

**2. BOOKS ARE A PROFITABLE STOCK ITEM**  
Our trade discounts allow you a good profit on each sale. Our wide promotion insures their sale without effort on your part.

*We can supply copy and cuts for your catalog and circulars with your imprint. Write us today for full information on our new radio books, our dealers' discounts and free promotional aids.*

The Macmillan Co., 60 Fifth Ave., New York 11  
Tech. Bk. Dept.

### ATTENTION!

● Students ● Service Men ● Hospitals

## BUILD YOUR OWN RADIO

● **It's Easy . . . We Show You How!**

We manufacture complete radio kits.

● 4 tube T.R.F. Kit complete with tubes \$10.95

● 6 tube Superheterodyne Kit complete with tubes \$17.95

### MULTI-TESTER KITS

● 6 voltage ranges, 3 current ranges \$14.95 and up  
4 ohm ranges

● **Special for this month!**

● 12" PM Speakers 16 oz. slug . . . \$4.95 each

● We manufacture complete radio kits. Tubes and parts at special prices. Send for details.

### RADIO KITS COMPANY

● Dept. M. 120 Cedar St. New York 6, N. Y.

FM stations on the air, I expect to see the number at least tripled or quadrupled during the next 12 months. Hundreds of additional stations will be under construction before the end of the year."



## Unusual Buy Cathode Ray Tubes



### & Television Parts New Factory Sealed Tubes for Television and Oscilloscopes

RCA 5BP4, price .....	\$18.00
DUMONT 5BP1, price .....	15.00
RCA Television switch with 5 Antennae RF transformers, price ....	5.60
G.E. CR Power transformer 1700 V., 6.3 V., 2.5 V., price .....	9.90
Cathode Ray tube Magnal socket 11 pole with H. Voltage wiring, price	2.40
Cornell-Dubilier Oil Filter tubular Capacitor .1 mfd 3500 V., price ....	1.80
.02 mfd 2500 V. Sprague tubular Capacitor, price .....	.90
All types ceramic, mica and oil capacitors, trimmers, coaxial cable, etc.	

Send 50c for complete catalog including diagrams for RCA, G.E., DUMONT and ANDREA Television Receivers, free with order \$5.00 and more.

RCA Parts and Equipment Distributors  
**World's First Specialized House  
In Television**

**ELECTRONICS SERVICE & SUPPLY**  
Dept. RC, 262 W. 40th Street,  
New York 18, N. Y.

## 500 FORMULAS TO SUCCESS

ANY million dollar firms started with a single formula, for which they paid a big price. Here you have 500—no less—tried and tested formulas, recipes and processes for making things . . . all at the ridiculously low price of 25c. Here is your opportunity to start a business with but a few dollars' capital and with undreamed of profits in prospect. You can also use these formulas in your own home to cut household expenses to the bone. Or you can put them to use in your workshop to cut costs as much as 1000%.



Quit paying out many dollars in profits to manufacturers, wholesalers, and dealers, when you can make the same thing yourself for a few cents. It's so easy when you follow our simple instructions.

66 PAGES. 3200 WORDS IN TEXT  
Send for "500 FORMULAS AND RECIPES" today. Enclose 25c, that's all! You won't be asked for another cent now or later. Sold on a money-back guarantee.

**NATIONAL PLANS COMPANY**  
P. O. BOX 26, R. STATION N. New York 23, N. Y.

## NATIONAL RADIO PARTS

**EXTRA-SPECIAL!** By-Pass Condenser Kit—Contains 100 popular sized tubulars .001 to .1 Mfd. All 600V. Fully guaranteed. Per Kit.....\$5.95

**AERIAL KITS**—Complete including instructions. (Individually boxed).....75c

**INSULATED RESISTOR KIT**—100 most popular sized Deluxe Asst. ¼, ½, 1 Watt R.M.A. color coded .....Per kit \$2.75

**RADIO KNOB KIT**—50 Bakelite Set Screw for ¼" shaft. Deluxe Asst. Per kit .....\$3.69

**RADIO KITS**—4 tube TRF including tubes. Special .....\$10.75

Write for Latest Bargain Parts Flyer—Just out!

**NATIONAL RADIO DISTRIBUTORS**  
Dept. R, 1029 East 163rd St., New York 59, N.Y.

Underwater sound bombs, exploded at a depth of 3,000 to 4,000 feet, are heard on electronic apparatus for 2,000 miles, in a new life-saving device called "Sofar."

## INDEX TO ADVERTISERS

Adson Co. ....	431
Aerovox Corp. ....	426
Allen Manufacturing Co. ....	434
Allied Radio Corp. ....	433
Amperite Co. ....	430
Amplifier Co. of America.....	432
Arrow Electronics.....	427
Arrow Radio Co. ....	440
Audel & Co., Theo. ....	412
Auto Power, Inc. ....	437
Bell Telephone Labs. ....	410
Buffalo Radio Supply.....	431
Burgess Battery Co. ....	431
Burstein-Applebee Co.....	432
Cannon Co., C. F.....	436
Capitol Radio Eng. Institute....	409
Chief Electronics.....	417
Cleveland Inst. of Radio Elec.....	411, 415
Commercial Equip. Co.....	423
Concord Radio Corporation.....	419
Cornell-Dubilier Elec. Corp. ....	376
Coyne Electrical School.....	380
Crabtree Wholesale Radio.....	436
Deacy, W. H. ....	417
DeForest's Training, Inc. ....	377
Electronics Service & Supply Co.	442
Electro-Voice Corp.	

### Inside Front Cover

Free Want Ad Service .....	437
General Cement Mfg. Co. ....	417
General Electric Co. ....	417
Harrison Radio Co. ....	425
Hazelton Instrument Co. ....	430
Hudson Specialties Co. ....	443
Kluge Electronics Corp. ....	405
Lake Radio Sales Co. ....	431
Leeds Radio Co. ....	439
LeJay Mfg. Co. ....	430
Liberty Sales Co. ....	439
Linguaphone .....	436
McElroy, T. R.....	427
McMurdo Silver Corp.....	375
MacMillan Co. ....	441
Maedel Publishing House.....	441
Maguire Industries.....	370, 371
Manhattan Parts Co. ....	430
Metropolitan Elec. Inst. Co.....	428
Miles Reproducer Co. ....	421

National Plans Inst.....	442
National Radio Distributors....	442
National Radio Institute.....	369
National Schools.....	379
National Union Radio Corp. ....	372
Nelson Co. ....	440
Newark Electric Co., Inc. ....	421
Onap & Sons, D. W. ....	421
Opportunity Adlets.....	439

### RADIO SCHOOL DIRECTORY

Page 444

American Radio Institute	
Candler System	
Cleveland Inst. of Radio Elec- tronics	
Commercial Radio Institute	
Lincoln Engineering School	
Mechanics Training School	
Melville Radio School	
RCA Institutes, Inc.	
Tri-State College	
YMCA	

Radio Corp. of America.....	378
Radio Distributing Co.....	436
Radio Electric Service.....	424
Radio Kits Co. ....	441
Radio Product Sales Co. ....	415
Radio Publications.....	440
Radio & Television Supply Co....	436
Radio Wire Television, Inc. ....	424
Radolek Co.....	430
Raytheon Mfg. Co. ....	Back Cover
Rider, John F. ....	413
Rudisill, Kenneth R. ....	427
Scenic Radio & Electronic Co. ...	440
Schott, Walter L. ....	421
Sprayberry Academy of Radio...373	
Superior Instrument Co.	

### Inside Back Cover

Supreme Inst. Co.....	435
Supreme Publications.....	435
Technical Division.....	406, 407
Terminal Radio.....	438
Triplett Elec. Instrument Co. ....	423
Ungar Electric Tools, Inc. ....	422
Van Nostrand Co. ....	443
Wholesale Radio Laboratories...429	
X. L. Radio Labs. ....	431

## THE CRYSTAL FILTER

(Continued from page 399)

side of the peak response frequency ( $f_R$ ).

Fig. 6 shows a set of actual receiver selectivity curves, based on the three curves just derived. The curves of Fig. 6 are modified to include the selective action of the receiver i.f. circuits, and they are also reversed to take account of the fact that the receiver oscillator is usually on the high side of the signal frequency. Curves b and d of Fig. 6 represent interpolations between curves a and c and between curves c and e. The following points are to be borne in mind:

1. Greatest selectivity is obtained with the phasing capacitor at its balanced position. No rejection frequency appears with this setting.

2. When the phasing capacitor is smaller than the value required for bal-

ance, a rejection "slot" appears below the frequency of peak response. When it is larger than the balanced value, a slot appears on the high side of the peak response frequency.

3. As the phasing capacitor is adjusted away from its balanced position, the rejection slot appears and moves in toward the peak response frequency. Minimum separation between the peak response frequency and the rejection frequency is obtained when the phasing capacitor is at its minimum or maximum setting.

The second article will deal with the actual, practical procedures necessary to realize optimum performance and satisfaction from the use of a crystal filter circuit.



## HARD-TO-GET PARTS

### POWERFUL ALL-PURPOSE INDUCTION MOTOR

IDEAL FOR EXPERIMENTERS—101 USES

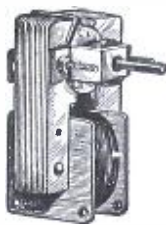

Sturdily constructed to precision standards, this self-starting shaded pole A.C. induction motor is powerful enough for a number of uses. Some of these are: Automatic Timing Devices, Current Interrupters, Electric Fans, Electric Chimes, Window Displays, Photocell Control Devices, Electric Vibrators, Small Grinders, Buffers and Polishers, Miniature Pumps, Mechanical Models, Sirens, and other applications.

Consumes about 15 watts of power and has a speed of 3,000 r.p.m. When geared down, this sturdy unit will constantly operate an 18-inch turntable loaded with 200 lbs. dead weight—THAT'S POWER! Dimensions: 3" high by 2" wide by 1 3/4" deep; has 4 convenient mounting studs; shaft is 1/8" long by 3/16" diameter, and runs in self-aligning oil-retaining bearings. Designed for 110-20 volts, 50-60 cycles, A.C. only. Shp. Wt. 2 lbs.

ITEM NO. 147  
YOUR PRICE ..... \$2.95

### ULTRA MAGNET

LIFTS MORE THAN 20 TIMES ITS OWN WEIGHT

LITTLE GIANT MAGNET

Lifts 5 lbs. easily. Weighs 4 oz. Made of A.I.N.I.C.O. new high-magnetic steel. Complete with keeper. Works most powerful magnet ever made. The experimenter and hobbyist will find hundreds of excellent uses for this high quality permanent magnet. Measures 1 3/4" x 1 1/4" Shp. Wt. 3/4 lbs.



ITEM NO. 159  
YOUR PRICE ..... \$1.50

### GENUINE MICROPHONE TRANSMITTERS



Regular telephone transmitters taken from a large telephone supply company's overstock. Work perfectly on 2 dry cells. Can be used on P.A. systems, call systems, intercommunications sets, short-line telephone circuits, house-to-house or farm-to-farm phone lines, also to talk through your own radio or as concealed telephone pick-up. Useful replacements on battery-operated rural telephone lines.

THESE ARE GENUINE TRANSMITTERS, MADE BY KELLOGG, WESTERN ELECTRIC AND STROMBERG-CARLSON, excellent in appearance and operation. A remarkable value and one seldom offered in these times. Shp. Wt. 1 lb.

ITEM NO. 160  
YOUR PRICE ..... \$1.50

### AMAZING BLACK LIGHT!!

Powerful 250-Watt Ultra-Violet Source



The best and most practical source of ultra-violet light for general experimental and entertainment use. Makes all fluorescent substances brilliantly luminescent. No transformers of any kind needed. Fits any standard lamp socket. Brings out beautiful opalescent hues in various types of materials. Swell for amateur parties, plays, etc.; to obtain unique lighting effects. Bulb only. Shp. Wt. 2 lbs.

ITEM NO. 87  
YOUR PRICE ..... \$1.95

### WESTERN ELECTRIC BREAST MIKE

This is a fine light-weight aircraft carbon microphone. It weighs only 1 lb.

Mike comes with breastplate mounting and has 2-way swiveling adjustment so that it can be adjusted to any desired position. There are 2 woven straps; one goes around neck, the other around chest. Straps can be snapped on and off quickly by an ingenious arrangement.

This excellent mike can be adapted for home broadcasting or private communication systems. By dimounting breastplate, it can be used as desk mike.

Comes complete with 0-foot cord and hard rubber plug. Finished in sherardized plate, non-rustable. Shipping weight, 2 lbs.

ITEM NO. 152  
YOUR PRICE ..... \$2.55

### WATTHOUR METER

Completely overhauled and ready for immediate service. Designed for regular 110-volt, 60 cycle 2-wire A.C. circuit. Simple to install; 2 wires from the line and 2 wires to the load. Sturdily constructed in heavy metal case. 8 1/2" high, 6 1/4" wide, 5" deep. Westinghouse, G. E., Ft. Wayne, Sangamo or other available make. Shp. Wt. 14 lbs.

ITEM NO. 33  
YOUR PRICE ..... \$4.95



### HUDSON SPECIALTIES CO.

40 West Broadway, Dept. RC-3-46, New York 7, N.Y.

I have circled below the numbers of the items I'm ordering. My full remittance of \$ (in-clude shipping charges) is enclosed (NO C.O.D. ORDERS UNLESS ACCOMPANIED WITH A DEPOSIT.) OR my deposit of \$..... is enclosed (20% required), ship order C.O.D. for balance. NO C.O.D. ORDER FOR LESS THAN \$5.00. BE SURE TO IN-CLUDE SHIPPING CHARGES.

Circle Item No. wanted:  
147 159 160 87 152 33

Name .....

Address .....

City .....

State .....

## SERVICING FM

(Continued from page 391)

ordinary signal generator and employ harmonics of the lower fundamental frequencies. For example, the fourth harmonic of 20 mc would be 80 mc. This range could be used for alignment in some cases.

A frequency-modulated signal generator and an oscilloscope combined provide the most accurate and convenient method of FM alignment, but a satisfactory job can also be done with an ordinary signal generator covering a range in the vicinity of 4.3 mc. The object of alignment is to adjust the trimmers so that the i.f. system has a band-pass from 4.225 to 4.375 mc, and then to adjust the detector coil to cover exactly the same band.

First disconnect the mixer coil from the control grid of the oscillator tube and connect the "hot" output terminal of the generator or oscillator to this grid and the ground terminal to the chassis.

Connect a 0-50 or 0-200 microampere meter in series with the grid leak of the limiter stage and ground. This will measure the current of the limiter tube, which should be about 30 to 100 microamperes.

Set the signal generator to 4.375 mc and align the i.f. trimmers for maximum response. Then go over all the trimmers and *tighten* them very slowly until a barely perceptible decrease in limiter grid current or bias voltage is noted. Repeat this procedure with all i.f. trimmers.

Then adjust the generator dial to 4.225 mc. The grid current should be approximately the same as at 4.375 mc. If it is not, adjust the i.f. trimmers for maximum response, leaving them in the *loosest* position which will give this response. Then repeat the previous adjustment at 4.375 mc. The output should remain nearly the same when tuning between 4.225 and 4.375 mc and should begin to decrease on each side of the two frequencies. The approximate i.f. response curve is shown in Fig. 2.

In cases where no signal generator is available, the FM stations themselves may be used for alignment of the r.f. stages. With the receiver adjusted to the high end of the band, an FM station can be tuned in and the r.f. shunt and oscillator shunt trimmers may be adjusted for maximum output and correct dial setting.

One important part of the serviceman's work in the near future will be conversion of low-frequency receivers sold before the war to the higher frequencies now coming into use. Most of the cheaper sets will be practically worn out and should be replaced rather than adapted, but many FM receivers were high-class jobs which represent a heavy investment to the owner and are still good for many years of service.

Converters will be manufactured or may be constructed by the servicemen

(Continued on following page)

# AT LAST!!

## A Complete, Practical Handbook of Present-day TELEVISION

Now, the tremendous opportunities in the field of television are brought within your reach—by means of this crystal-clear book. Written in plain English, concise and up to the minute, it makes television easy to understand. There is no mathematics to confuse you and make explanations difficult to follow. Hundreds of vivid illustrations bring every fact and point right before your eyes. You'll be amazed at how simple television can become with

# TELEVISION SIMPLIFIED

by MILTON S. KIVER

Associate Instructor in radio, U.S. Army Air Forces. Formerly Instructor in radio, Illinois Institute of Technology.

This brand-new, authoritative handbook not only contains all the information you need for success in television, but covers the trouble shooting and repair of radio sets. Beginning with a clear, overall picture of the entire field, it breaks down the television receiver into its component parts and circuits. It analyzes them, step by step, showing how they are formed, the roles they play, and their operating characteristics.



### BRIEF OUTLINE OF CONTENTS

The Television Field; Ultra-high Frequency Waves and the Television Antenna; Wide-band Tuning Circuits, Radio-frequency Amplifiers; The High-frequency Oscillator, Mixer and Intermediate-frequency Amplifiers; Diode Detectors and Automatic Volume-control Circuits; Video Amplifiers; Direct-current Reinsertion; Cathode-ray Tubes; Synchronizing Circuit Fundamentals; Deflecting Systems; Typical Television Receiver—Analysis and Alignment; Color Television; Frequency Modulation; Servicing Television Receivers; Glossary of Television Terms.

### EXAMINE THIS BOOK FREE

Let this book prepare you to take advantage of the brilliant opportunities television offers. Send for it NOW!

By the same author:  
U.H.F. RADIO SIMPLIFIED . . . \$3.25.  
A complete, up-to-date book on the methods and equipment used in ultra high frequency radio, that has so many applications in war and peace.

### MAIL THIS COUPON

D. VAN NOSTRAND COMPANY, INC.

250 Fourth Avenue, New York 3, New York

Please send me the book or books I have checked.

Television Simplified @ \$4.75.

U.H.F. Radio Simplified @ \$3.25.

Within 10 days I will either return the book or books, or send you the purchase price plus a few cents postage. (If you enclose check or money order with this coupon, we will pay the postage. Same return privilege and refund guarantee).

Name.....

Address.....

City..... State.....

Radio Craft, Mar. 46



# RADIO SCHOOL DIRECTORY

PREPARE NOW FOR SKILLED JOBS IN RADIO AND ELECTRONICS

MAKE a place for yourself in a new world of radio and electronics—a world in which revolutionary electronic developments will require highly specialized technical knowledge. Take a good course now to fit yourself for a good paying job. The training you need can be supplied by one of the schools advertised in this publication.

**RCA INSTITUTES, Inc.**  
Offer thorough training courses in all technical phases of **Radio and Television**  
DAYS—EVENINGS WEEKLY RATES  
**VETERANS:** RCA Institutes is approved under G. I. Bill of Rights  
For Free Catalog Write Dept. RC-46  
**RCA INSTITUTES, Inc.**  
A Radio Corporation of America Service  
75 VARICK STREET NEW YORK 13, N. Y.

**RADIO**  
Train with professionals. Complete, intensified courses; Repair & Maintenance, Communications, High-speed telegraphy, Slip transcription, FCC exams etc.  
High School Students accepted for training as Merchant Marine Radio Officers. Gov't sponsorship available to veterans.  
"A Radio School managed by radio men."  
45 W. 45th St., Dept. RC, New York 19, N. Y.  
**MELVILLE RADIO INSTITUTE**

**RADIO ENGINEERING**  
DEGREE IN 27 MONTHS  
VETERANS can complete work here in shortest possible time. Special Prep. Dep't. Also **FRESHER COURSES.** Courses also in Civil, Electrical, Mechanical, Chemical, Aeronautical Engineering; Business Administration, Accounting, Secretarial Science. Tuition, living costs low. 63rd year. Cosmopolitan student body. Enter Mar., June., Sept., Jan. Catalog.  
**TRI-STATE COLLEGE** 2426 College Ave. ANGOLA INDIANA

**RADIO**  
RADIO Technician and Radio Communications courses. Register now for new classes starting first MONDAY of each month. Day and Evening Classes.  
**AMERICAN RADIO INSTITUTE**  
101 West 63rd St., New York 23, N. Y.  
APPROVED UNDER GI BILL OF RIGHTS.

**CODE SENDING SPEED**  
Be a "key" man. Learn how to send and receive messages in code by telegraph and radio. Commerce needs thousands of men for jobs. Good pay, adventure, interesting work. Learn at home quickly through famous Candler System. Write for FREE BOOK.  
**CANDLER SYSTEM CO.**  
Dept. 3-C, Box 928, Denver 1, Colo., U.S.A.

## START YOUR OWN REFRIGERATION REPAIR SHOP!

Exceptional opportunity for men of all ages up to 60 who like to work with tools. Learn to be a service mechanic in REFRIGERATION. Our practical, thorough home training is easy to grasp in your spare hours with a common school education. Learn how to start your own business with \$50.00 worth of tools in garage, basement or small shop. Or take a well paid job in this active field.  
• Write for FREE BOOKLET today.

**FREE Booklet**  
**MECHANICS TRAINING SCHOOL**  
7217 So. Broadway Dept. C-3 Los Angeles 3, Calif.

**LES Correspondence Courses in RADIO and ELECTRICAL ENGINEERING**  
**ELECTRICAL ENGINEERING** Get good grasp of wide electrical field. Prepare yourself, at Low Cost, for secure future. Modern, simplified, you can understand quickly.  
**RADIO ENGINEERING** Extra fine course in radio, public address, photo-electric work. Trains you to be super-service man, real vacuum tube technician. Servicemen needed badly. Diploma on completion. Tuition \$25, either course. Deferred payment plan.  
**FREE** Get copies of school catalogs, student magazines, complete details. SEND NOW!  
**LINCOLN ENGINEERING SCHOOL** 8-x 9316-R5 Lincoln, Nebr.

**RADIO**  
Home Study Courses for Radio Technicians and Radio Engineers. Prepare now for a better Radio-Electronics job. Free Booklet. See our large ads. on pages 411 and 415.  
**Cleveland Institute of Radio Electronics**  
RC-3 Terminal Tower Cleveland 13, Ohio

**COMMERCIAL RADIO INSTITUTE**  
A radio training center for twenty-four years.  
RESIDENT COURSES ONLY  
Broadcast, Service, Aeronautical, Television and Marine telegraphy classes now forming. Literature upon request. Veteran training. Classes now forming for mid-year term. Dept. C, 38 West Biddle St., Baltimore 1, Md.

**RADIO COURSES**  
• RADIO OPERATING • CODE  
• RADIO SERVICING — ELECTRONICS  
• REFRIGERATION SERVICING  
Personal Counselling Services for Veterans  
Write for Latest Trade & Technical Catalog  
**Y.M.C.A. TRADE & TECHNICAL SCHOOLS**  
4 W. 64th Street New York City

## SERVICING FM (Continued from page 443)

(see *Radio-Craft*, June, 1945). The fitting of them to a receiver should be a simple matter, as most of the larger FM receivers have ample cabinet space and the converter may be mounted inside, near the antenna stage—possibly fastened to the side of the cabinet.

The old dipoles will also need to be adapted to the new frequencies. This can be done by cutting the old antennas roughly in two, as they were usually a little more than eleven feet long, and

a five-foot antenna will receive best at approximately the center of the new band.

The same fundamental principles of locating a dead stage, hum, or noise in AM sets may be used in servicing FM sets to a considerable extent, but to say that both types of radios are exactly alike with respect to servicing is to distort the facts. FM radios definitely have peculiarities which must be learned if they are to be serviced efficiently.

## RADAR LOCATES HURRICANE

RADAR instruments developed for war purposes may play an important part in future weather forecasting and also make permanent records relative to the nature of storms and their movements for use in the science of meteorology it was revealed last month by Army experts at Orlando, Fla. The entire progress of last September's hurricane in its gradual curve up Florida was accurately plotted on film by Army radar war equipment. Photographs of each radar scope were taken each 15 seconds by electrically operated cameras, and studied by the radar-meteorological experts.

Throughout the hurricane the general shape of the disturbance was plainly seen on the micro-wave set, whose energy was reflected excellently from the rain carried by the storm. The storm was seen to be in the shape of a figure six with clockwise spiralling tails. At one time six distinct tails were observed, three of which were detached and were moving northward ahead of the storm's center. These tails were deduced to be rain-bearing storm clouds, or line squalls eight to ten miles in width and from three to five miles apart.

When the hurricane was abreast of the radar station, and only 10 miles away, the radar revealed that the eye of the storm, the low pressure area in its center, was 12 miles in diameter, and the lack of echoes proved that there was no precipitation within it. The height-finding radar set revealed that the dense cloud deck surrounding the eye extended up to an average height of 18,000 feet.

## V.H.F. LANDS PLANES

VERY HIGH FREQUENCY radio transmitters (v.h.f. for short) will soon be installed at 12 major American airports to assist speedy and safe landings of commercial airliners, it is announced by the Civil Aeronautics Administration. It is expected that they will be ready for use this winter. While the ground installations are being made, airplane companies will be equipping their airliners with the necessary airborne v.h.f. apparatus.

The v.h.f. equipment is used in connection with a new landing technique developed by the CAA. It makes possible safe aircraft instrument landings at overcast airports at three-minute intervals. By this method approximately 20 planes can be brought safely down on a single runway in an hour, while under the usual method the number is only four or five.

The very high frequency radio is the key to the new technique. Its great advantage is that it is basically static-free. With the present low-frequency radio, static causes much difficulty, and is worse in bad weather when clear reception is most needed. Approach guidance is by means of a localizer element, which is also operated on very high frequencies.



PLEASE PLACE YOUR ORDER WITH YOUR REGULAR RADIO PARTS JOBBER. IF YOUR LOCAL JOBBER CANNOT SUPPLY YOU, KINDLY WRITE FOR A LIST OF JOBBERS IN YOUR STATE WHO DO DISTRIBUTE OUR INSTRUMENTS OR SEND YOUR ORDER DIRECTLY TO US.

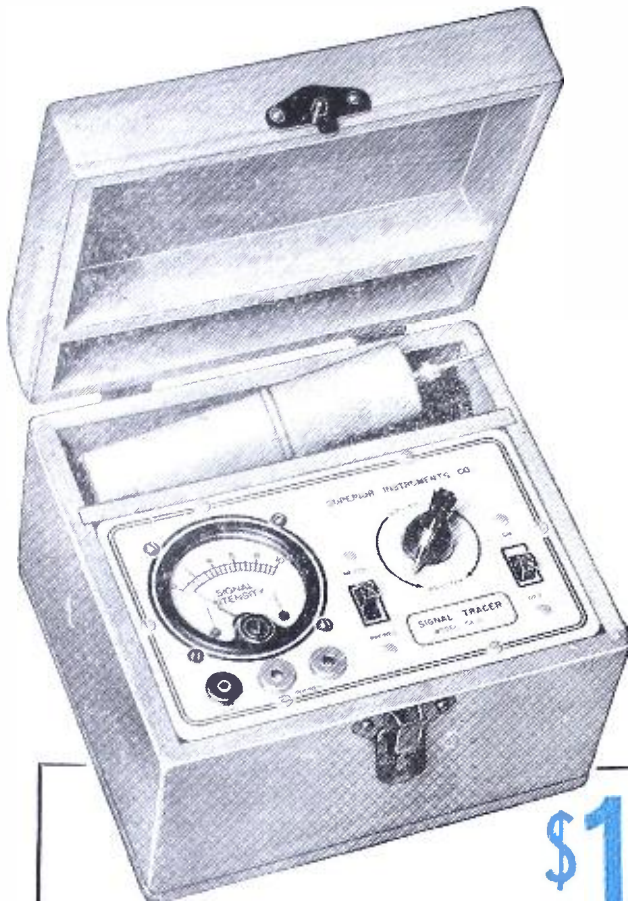

## The New Model CA-11 SIGNAL TRACER

Simple to operate . . . because signal intensity readings are indicated directly on the meter!

Essentially "Signal Tracing" means following the signal in a radio receiver and using the signal itself as a basis of measurement and as a means of locating the cause of trouble. In the CA-11 the Detector Probe is used to follow the signal from the antenna to the speaker — with relative signal intensity readings available on the scale of the meter which is calibrated to permit constant comparison of signal intensity as the probe is moved to follow the signal through the various stages.

### Features:

- ★ SIMPLE TO OPERATE — only 1 connecting cable — NO TUNING CONTROLS.
- ★ HIGHLY SENSITIVE — uses an improved Vacuum Tube Voltmeter circuit.
- ★ Tube and resistor-capacity network are built into the Detector Probe.
- ★ COMPLETELY PORTABLE — weighs 5 lbs. and measures 5" x 6" x 7".
- ★ Comparative Signal Intensity readings are indicated directly on the meter as the Detector Probe is moved to follow the Signal from Antenna to Speaker.
- ★ Provision is made for insertion of phones.

The Model CA-11 comes housed in a beautiful hand-rubbed wooden cabinet. Complete with Probe, test leads and instructions.....Net price

**\$18<sup>75</sup>**

## The New Model 450 TUBE TESTER



### Specifications:

- Tests all tubes up to 117 Volts including 4, 5, 6, 7, 7L, Octals, Loctals, Bantam Junior, Peanut, Television, Magic Eye, Hearing Aid, Thyratrons, Single Ended, Floating Filament, Mercury Vapor Rectifiers, etc. Also Pilot Lights.
- Tests by the well-established emission method for tube quality, directly read on the scale of the meter.
- Tests shorts and leakages up to 3 Megohms in all tubes.
- Tests individual sections such as diodes, triodes, pentodes, etc., in multi-purpose tubes.
- New type line voltage adjuster.
- NOISE TEST: Tip jacks on front panel for plugging in either phones or external amplifier will detect microphonic tubes or noise due to faulty elements and loose internal connections.
- Works on 90 to 125 Volts 60 Cycles A.C.

**SPEEDY OPERATION** assured by newly designed rotary selector switch which replaces the usual snap, toggle, or lever action switches.

The model 450 comes complete with all operating instructions. Size 13"x12"x6". Net weight 8 lbs. **\$39<sup>50</sup>** Our Net Price.....

## The Model PB-210 MULTI-METER



### Features:

- ★ SPEEDY!
- ★ PUSH-BUTTON OPERATION!

### Measures:

- ★ A.C. Volts
- ★ D.C. Volts
- ★ D.C. Current
- ★ Low Resistance
- ★ High Resistance
- ★ High Resistance
- ★ Low Capacity
- ★ High Capacity
- ★ Decibels

### Specifications:

5 A.C. VOLTAGE RANGES: 0 to 10/50/250/500/1000 Volts  
 5 D.C. VOLTAGE RANGES: 0 to 10/50/250/500/1000 Volts  
 5 OUTPUT METER RANGES: 0 to 10/50/250/500/1000 Volts  
 4 D.C. CURRENT RANGES: 0 to 1/10/100 Ma. 0 to 1 Amp.  
 2 CAPACITY RANGES: .0005 Mfd. to .3 Mfd. .25 Mfd. to 100 Mfd.  
 3 DECIBEL RANGES: —10 to +15; +10 to +35; +30 to +55  
 4 RESISTANCE RANGES:  
 0 to 2,000/20,000/200,000 Ohms. 0 to 20 Megohms

Model PB-210 comes housed in hand-rubbed oak portable cabinet, complete with cover, self-contained battery, test leads and instructions. Net Price.....

**\$35<sup>75</sup>**



# SUPERIOR INSTRUMENTS CO.

Dept. R 227 FULTON ST., NEW YORK 7, N. Y.



**For Peak Performance**

*Depend on*  
**RAYTHEON BONDED  
ELECTRONIC TECHNICIANS**



Bonded by



## A "STAR SALESMAN" FOR YOU!

Every customer who comes to your counter will see this effective wall banner. It tells them you're a dependable, square-dealing Raytheon Bonded Electronic Technician — and brings them back to spend money with you.

This selling wall banner is only one of many carefully designed sales-aids — displays, decals, mailing pieces, job record cards — for you to use in building a lasting, money-making radio service business. Bonded service means better customer relations. See your Raytheon distributor today.

*Another reason why it pays to qualify as a Raytheon Bonded Electronic Technician.*



*Excellence in Electronics*

**RADIO RECEIVING TUBE DIVISION**

NEWTON, MASS. • NEW YORK • CHICAGO



# ADV Plans, LLC

## Copyright Notice:

The entire contents of this CD/DVD are copyright 2014 by ADV Plans, LLC. All Rights Reserved.

Reproduction or distribution of this disk, either free or for a fee is strictly prohibited. We actively monitor and remove listings on eBay thru Vero.

You are free to copy or use individual images in your own projects, magazines, brochures or other school projects.

Only the sellers listed here are authorized distributors of this collection:  
[www.theclassicarchives.com/authorizedsuppliers](http://www.theclassicarchives.com/authorizedsuppliers)

Please view our other products at  
[www.theclassicarchives.com](http://www.theclassicarchives.com),  
or our ebay stores:

[TheClassicArchives](#)  
[ADVPlans](#)  
[SuperShedPlans](#)

